

No.	PARTS NAME	MATERIAL	NOTES	QTY	SIZE
①	WALL MOUNT	STEEL	BLACK	2	450x59.5x20
②	DISPLAY BRACKETS	STEEL	BLACK	2	430x31.5x30
③	BOLT-1	STEEL	BLACK CR3	4	M6x60
④	BOLT-2	STEEL	BLACK CR3	4	M6x35
⑤	BOLT-3	STEEL	BLACK CR3	4	M6x25
⑥	BOLT-4	STEEL	BLACK CR3	4	M6x20
⑦	BOLT-5	STEEL	BLACK CR3	4	M6x12
⑧	BOLT-6	STEEL	BLACK CR3	4	M5x16
⑨	BOLT-7	STEEL	BLACK CR3	4	M4x16
⑩	WASHER	STEEL	CR3	4	OUTER φ13-INNER φ6.5 t=2
⑪	SPACER-A	RESIN (ABS)	BLACK	4	t10
⑫	SPACER-B	RESIN (ABS)	BLACK	4	t20
⑬	WRENCH	STEEL	CR3	1	M6
⑭	SPANNER	STEEL	CR3	1	M6

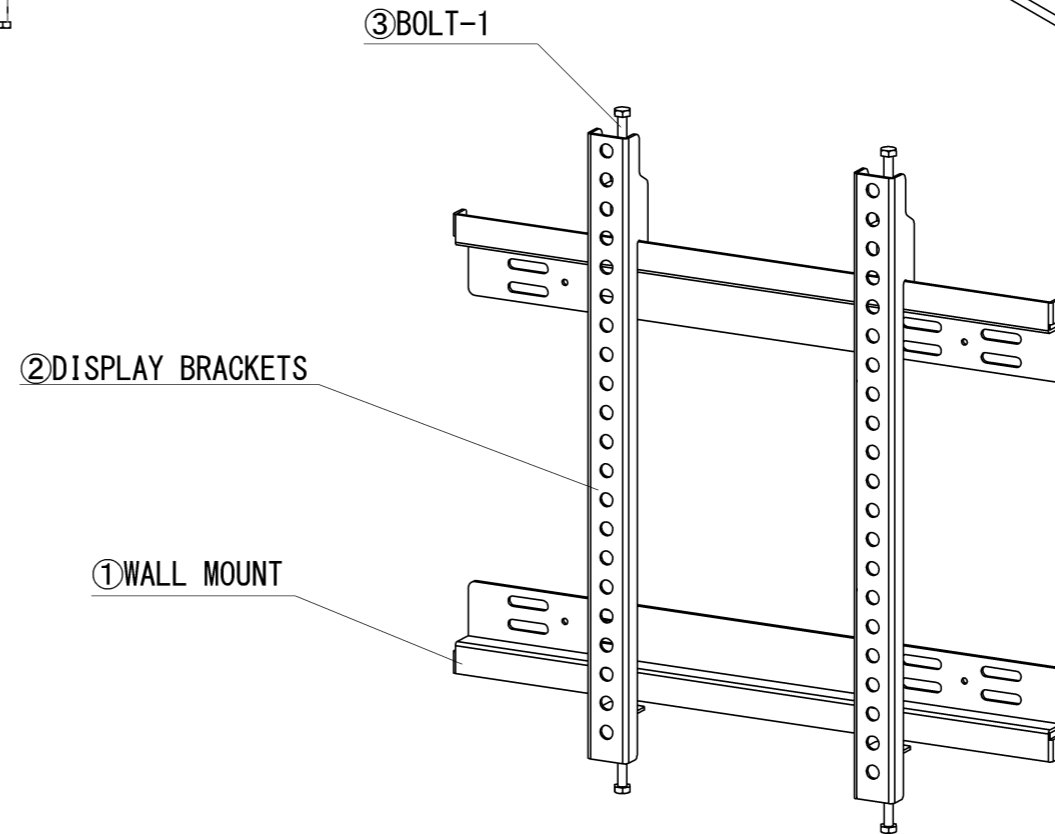
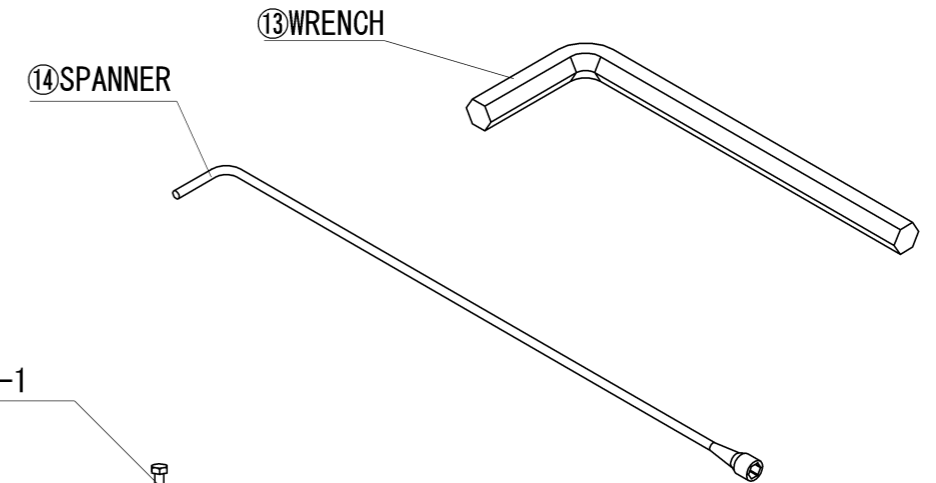

MARK	ALTERATION CONTENTS	ALTERATION DATE	DRAWN BY
△x			
△x			
△x			
△x			
△x			

DATE: 2016. 11. 8

承認 APPROVED BY	検閲 CONFIRMED BY	担当 PLANNED BY	製図 DRAWN BY	部品番号 PART NO.	部品名称 TITLE
YAMAMOTO	SATO	NAKANO	NAKANO		Display Brackets & Wall Mount
				材質 MATERIAL	個数 QTY
				材料寸法 SIZE	図番 DRAWING NO.

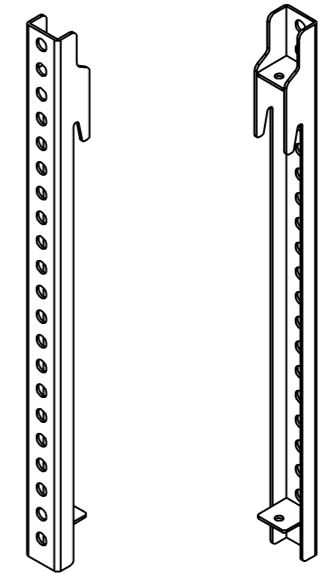
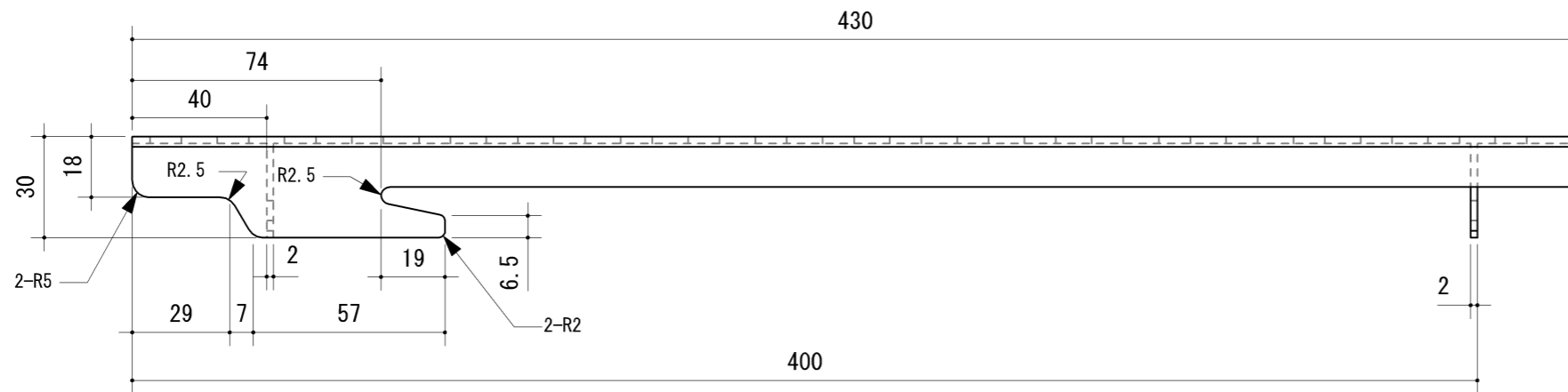
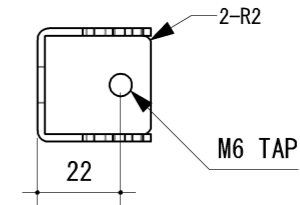
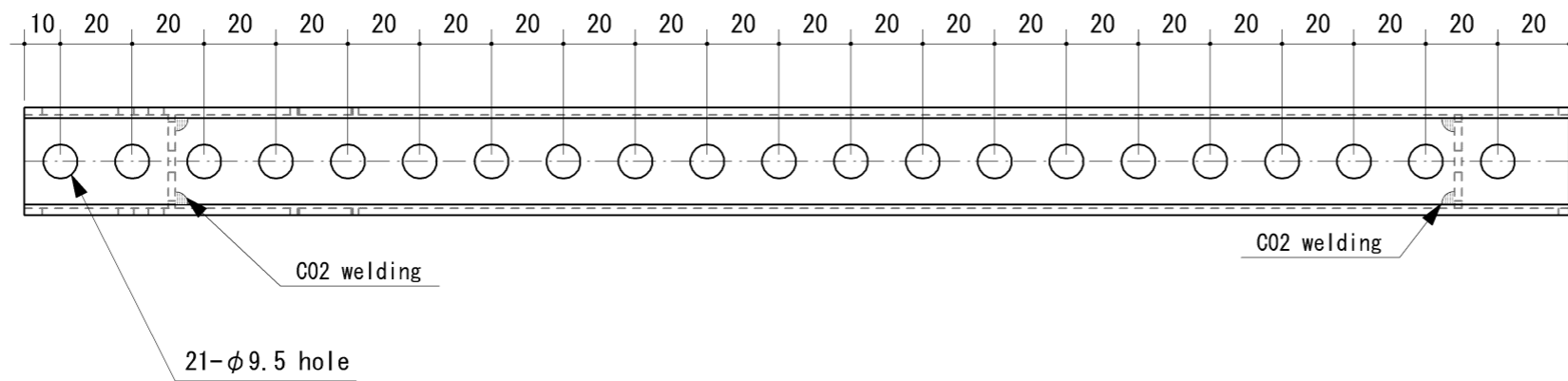
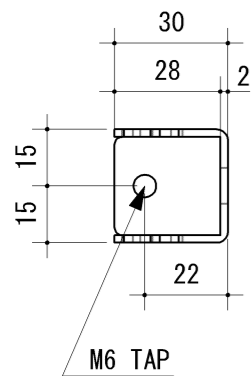

NOTE) WITHOUT BURR, SHARP-EDGES, LUST.

NOTE) PAINTING COLOR : BLACK (small embossing)

—— ref. Painting color sample.

△x			
△x			
△x			
△x			
△x			
MARK	ALTERATION CONTENTS	ALTERATION DATE	DRAWN BY

DATE: 2015. 06. 24

STAMP	STAMP	承認 APPROVED BY	検図 CONFIRMED BY	担当 PLANNED BY	製図 DRAWN BY	部品番号 PART NO.	部品名称 TITLE
		YAMAMOTO	SATO	NAKANO	NAKANO	○	DISPLAY BRACKET
						材料 MATERIAL	個数 QTY
						STEEL : PAINTED BLACK	2
						材料寸法 SIZE	図番 DRAWING NO.
						430x30x30	

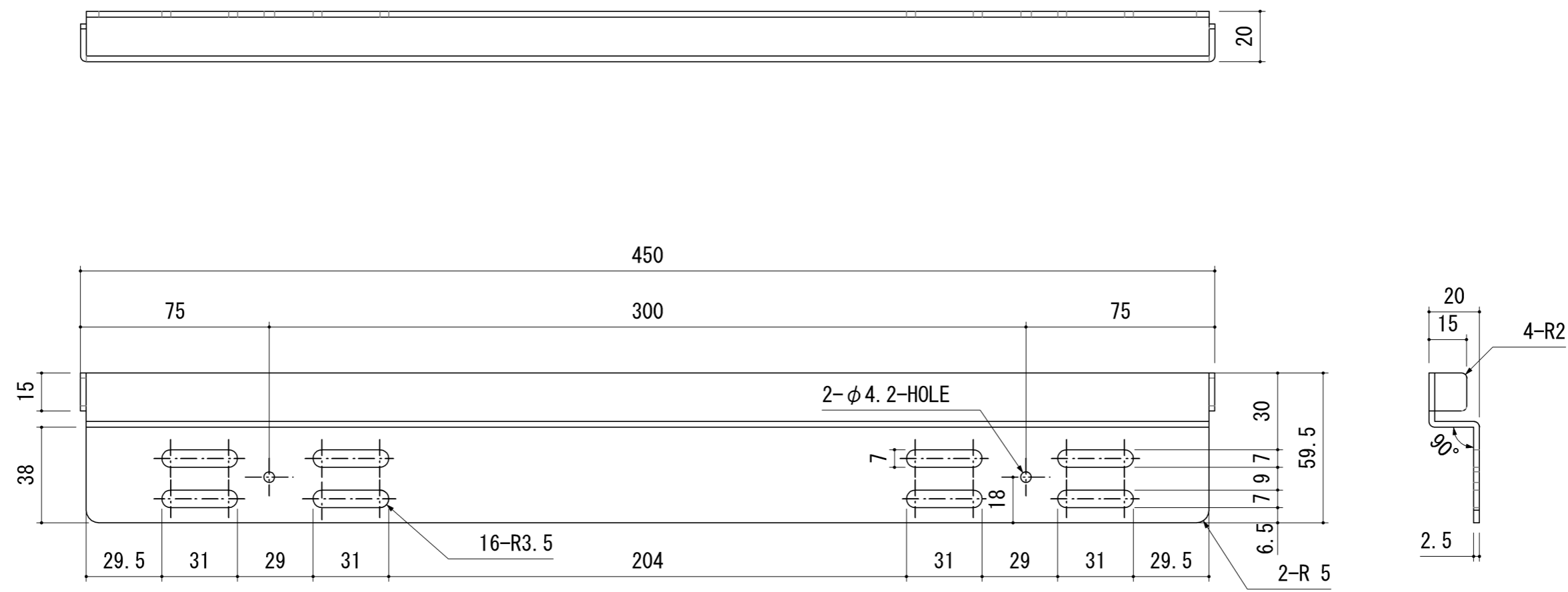

NOTE) WITHOUT BURR, SHARP-EDGES, RUST.

NOTE) PAINTING COLOR : BLACK (small embossing)

ref. Painting color sample.

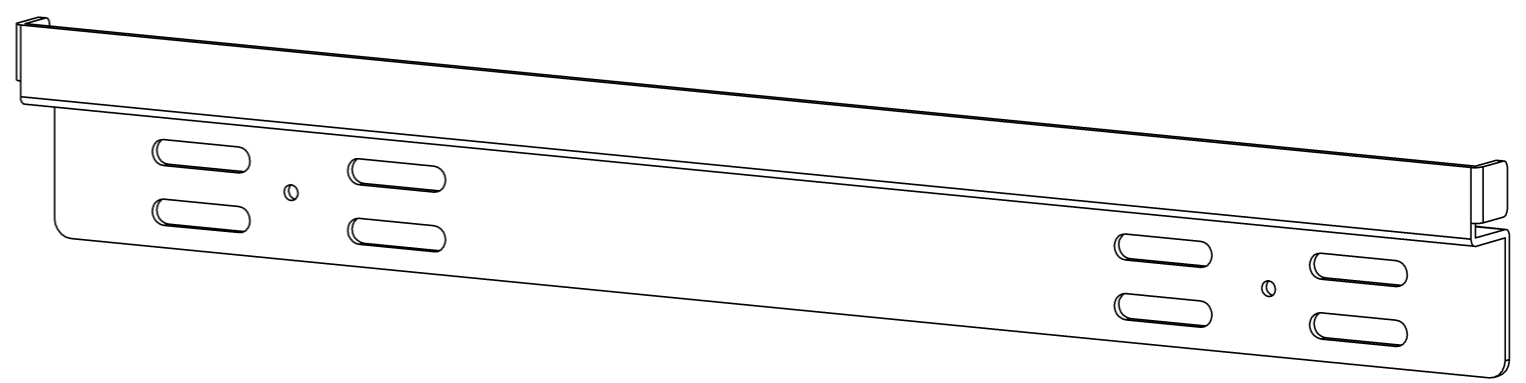

△x			
△x			
△x			
△x			
△x			
MARK	ALTERATION CONTENTS	ALTERATION DATE	DRAWN BY

DATE: 2016. 11. 8

STAMP	STAMP	承認 APPROVED BY	検図 CONFIRMED BY	担当 PLANNED BY	製図 DRAWN BY	部品番号 PART NO.	部品名称 TITLE
		YAMAMOTO	SATO	NAKANO	NAKANO	1	WALL MOUNT
							型名 MODEL NO.
							MH-STD11-BK
		材料 MATERIAL				個数 QTY	
		STEEL : PAINTED BLACK				2	
		材料寸法 SIZE				図番 DRAWING NO.	
		450x59.5x20					