

- Please read manual carefully before assembly and strict accordance with it.
- Please spray the body in a ventilated place and wear a safety mask.
- Please use ABS special glue for bonding when assembling the plastic body. Before bonding, please clean the bonding surface first and make sure free of paint, then pressure on the two adhesives with 10 seconds at least to fully bond.
- Please try to simulation assembly for determine the assembly sequence before the body parts are bonded or painted.
- Please refer to the instructions on page 50 for wiring diagram of electronic equipment. When it comes to power testing, get the truck off the ground.

● Electronic equipment requirements and recommendations:

Equipment	Specification	Remark
Radio system	Radio system with 4-channel or above	4 channels: front and rear, steering, shifting, front and rear differential open or locking at the same time; 6 Channels: front and rear differential open or locked separately; Remote control of light system on or off.
Servo	Standard steering	Standard Servo with waterproof function. Strength greater than: 30kg
	Gearshift servo *1 Differentials lock Servo * 1 (Front and rear differential independent control requires 2 servos)	The size of 25g Servo as Figure 1
Electronic speed controller	Continuous current $\geq 80A$	ESC BEC output $>3A$
Motor	Model 550, 35T or above brush motor	Outline size not exceed: Assembly hole distance: 25mm
Brushless system	$>60A$ $<1800KV$ $\leq 3S$ LiPo	Gear m0.8 12T 14T 16T

Figure 1: (unit: mm)

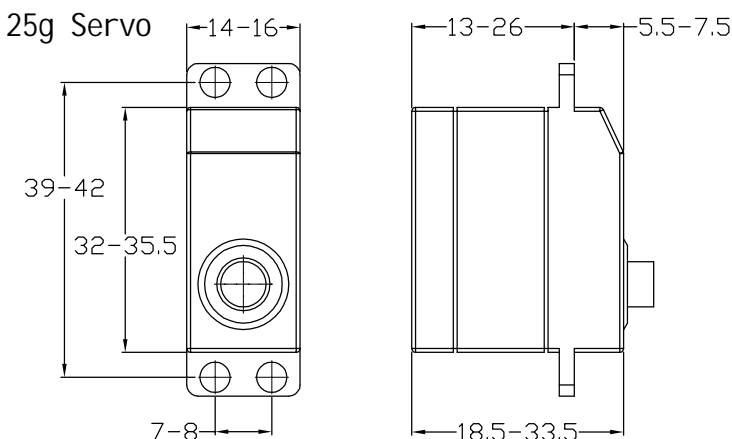

CAUTIONS



To prevent serious personal injury and/or property damage, operate all remotely controlled models in a responsible manner as outlined herein.

● Safety Precautions

- 1.1 Choose a right place to operate your RC model.
- 1.2 Do not operate your RC model on the street or highway. It can cause a serious damage or a serious accident.
- 1.3 Never operate your RC model near people or animals.
- 1.4 Do not operate RC model in public places like hospital and residential areas.
- 1.5 Never operate RC model indoors. There is a higher possibility of fire or damage.
- 1.6 Keep the parts out of reach of children, small parts can cause choking and vinyl bags can suffocate.
- 1.7 Do not use with children younger than 14 years.

● Inspect your RC model before operation

- 2.1 Make sure that all screws and nuts are properly tightened. It is also a good idea to use removable thread lock wherever metal screws go into metal, especially for engine mounts and the engine pilot shaft.
- 2.2 Always use fresh batteries for your transmitter and for your receiver to avoid losing control of the model.
- 2.3 Always test the brakes and throttle before starting your engine to avoid losing control of the model.
- 2.4 Always turn on the transmitter first, and then turn on the receiver.

● After operation of your RC model

- 3.1 Turn off receiver first, then turn off transmitter, this will prevent runaways.
- 3.2 Be careful when handling batteries, they will be hot after running.
- 3.3 Replace any batteries that have been dented or have frayed wires, short circuits can cause fire.

TOOLS

(Not included)

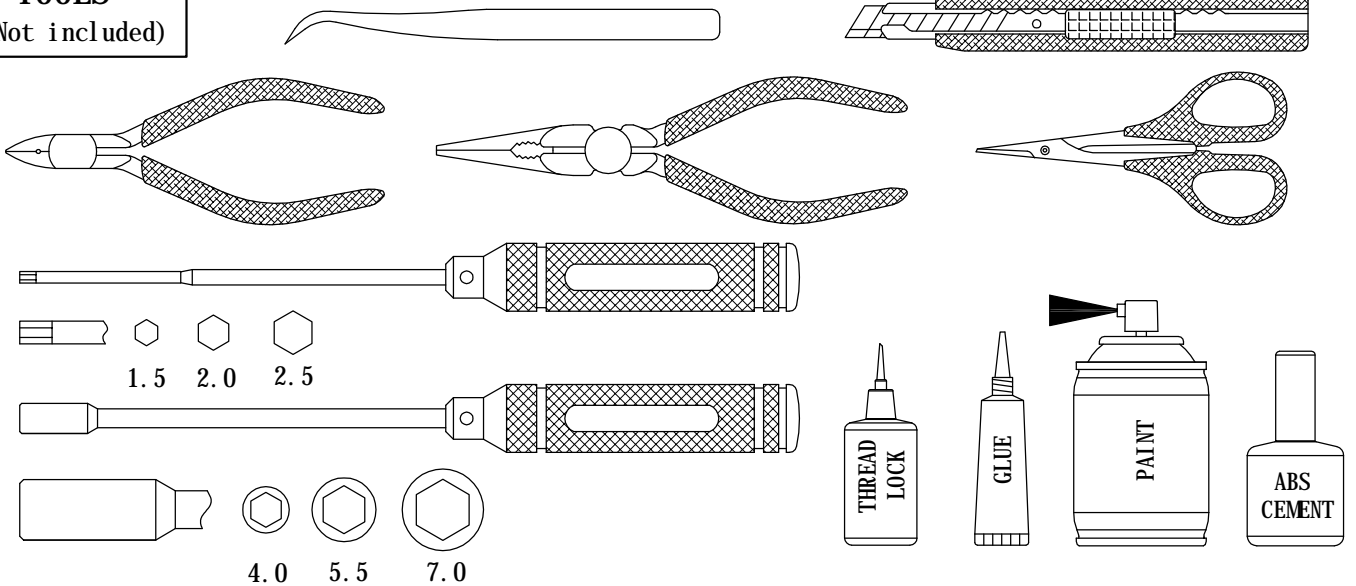

Electronic equipment

(Not included)

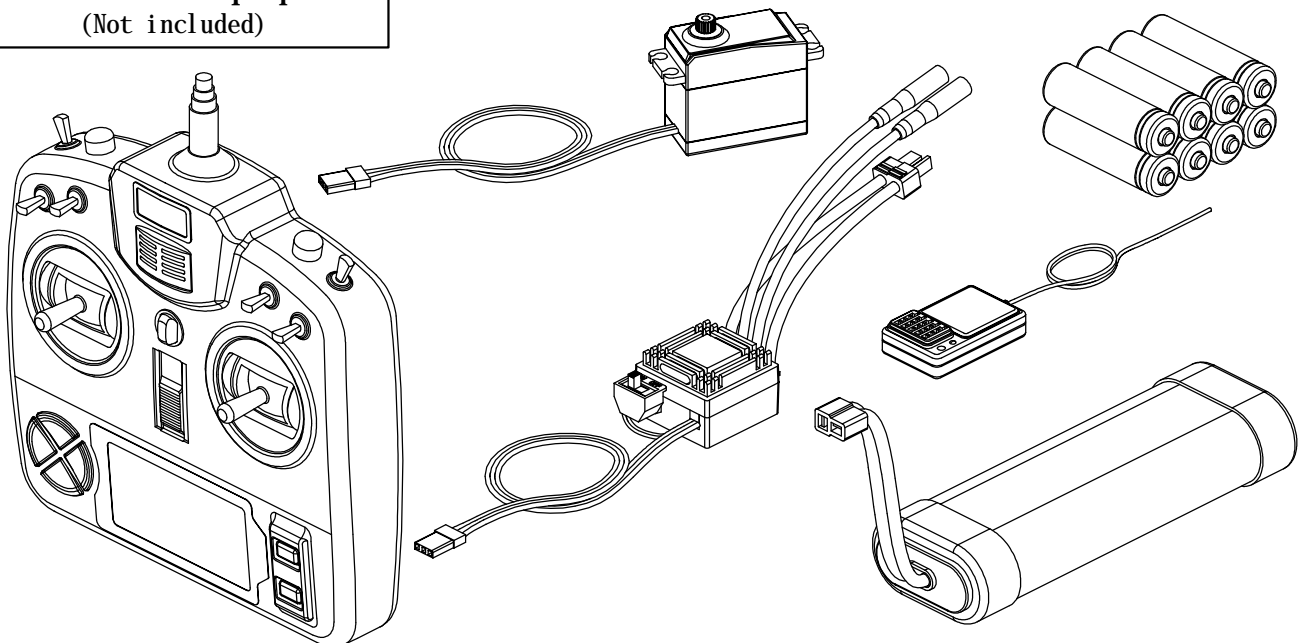

FRAME

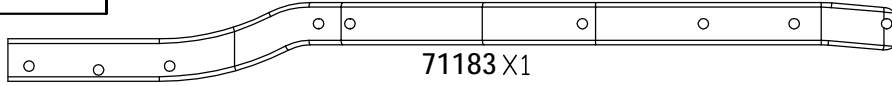

71183 X1

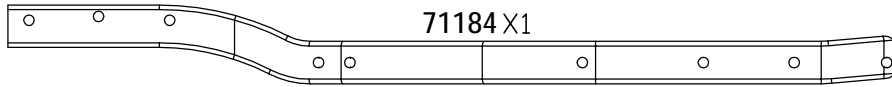

71184 X1



91006 X1



91007 X1

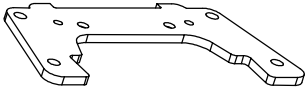

71186 X1

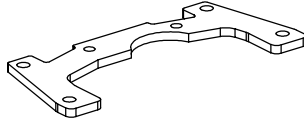

71187 X1



71188 X1



71225 X3

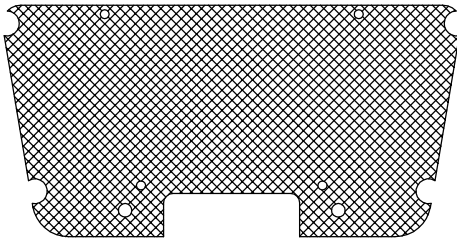

71191 X1

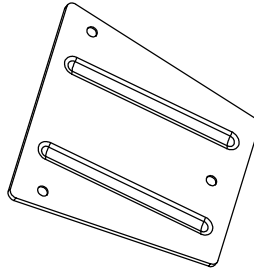

71189 X1



75017 X2



75016 X1

BAG(A)



94044-12T X1

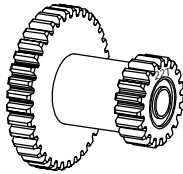

41525-36T/22T X1

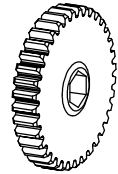

41526-33T X1

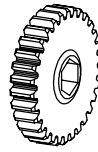

41527-30T X1



41529-18T X1

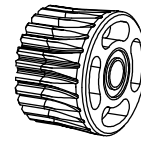

41528-25T X1



41531-16T X1

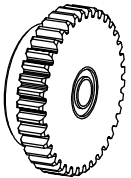

41530-37T X1

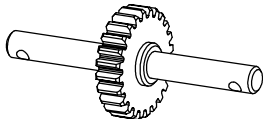

41545-24T X1

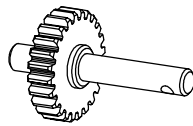

41532-24T X1

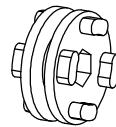

41513 X1

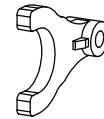

31405 X1



Ø5xØ10x4 X14
15003

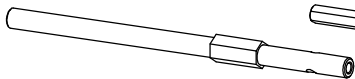

41540 X1



41618 X1

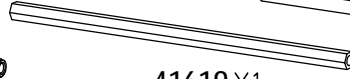

41619 X1

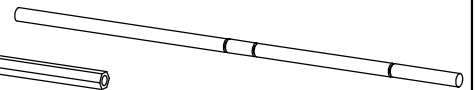

41541 X1

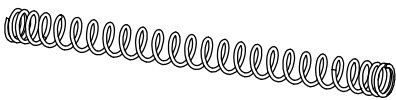

41384 X1



11207 M3x10 X4

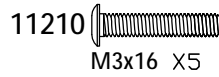

11210 M3x16 X5

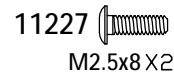

11227 M2.5x8 X2



41539 X1

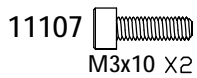

11107 M3x10 X2

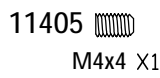

11405 M4x4 X1

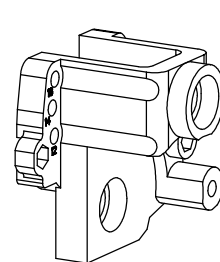

33602 X1

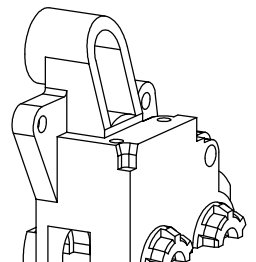

33601 X1



72007 X4



13006 X4



13003 X3



41616 X1



41617 X1



41712 Ø2.5x8 X1

BAG(B)

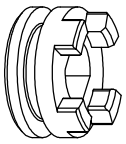

44097 X2

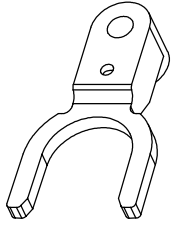

44096 X2

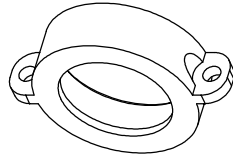

44098 X2

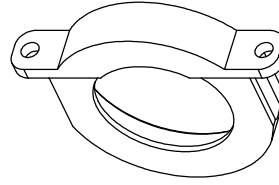

44099 X2

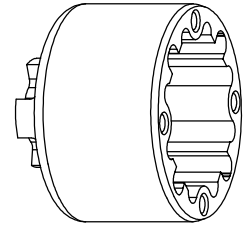

44116 X2

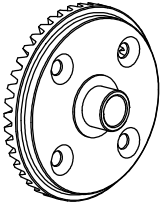

33603 X2



33605 X4



33604 X2



33606 X8

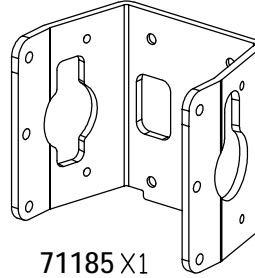

71185 X1



71190 X1

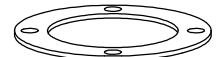

91119 X2



41385 X2



41703 X2

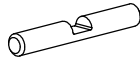

41700 X4



41701
Ø2.5x12 X2



13006
Ø5xØ9.8x0.5 X2



17006 X4



14108 X4

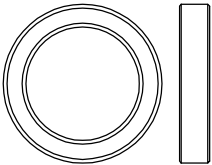

Ø15xØ21x4 X2
15011

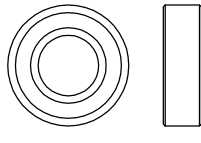

Ø8xØ16x5 X7
15009

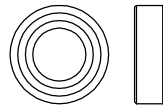

Ø7xØ13x4 X2
15010

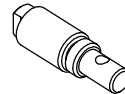

41543 X2

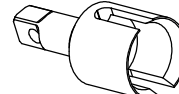

41538 X1

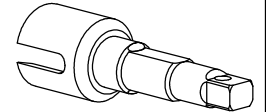

41537 X1

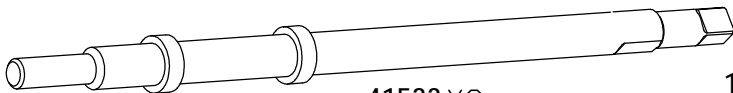

41533 X2

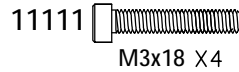

11111
M3x18 X4

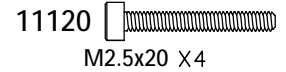

11120
M2.5x20 X4



11106
M3x8 X2

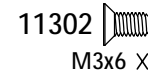

11302
M3x6 X1



11303
M3x8 X1

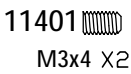

11401
M3x4 X2

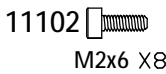

11102
M2x6 X8

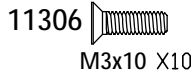

11306
M3x10 X10

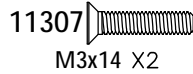

11307
M3x14 X2

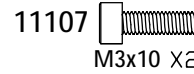

11107
M3x10 X2

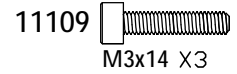

11109
M3x14 X3

TIRES AND WHEELS

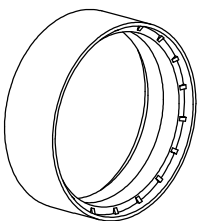

209903 X4

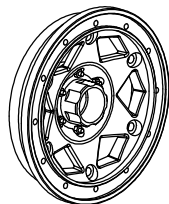

209902 X4

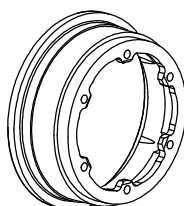

209901 X4

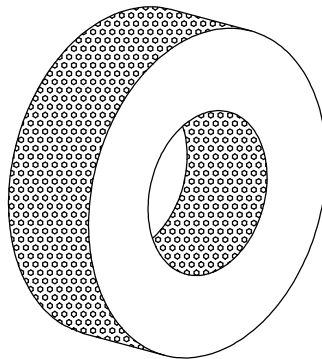

42322 X4

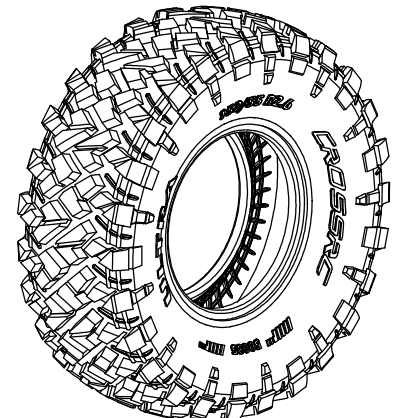

50035 X4

BAG(C)

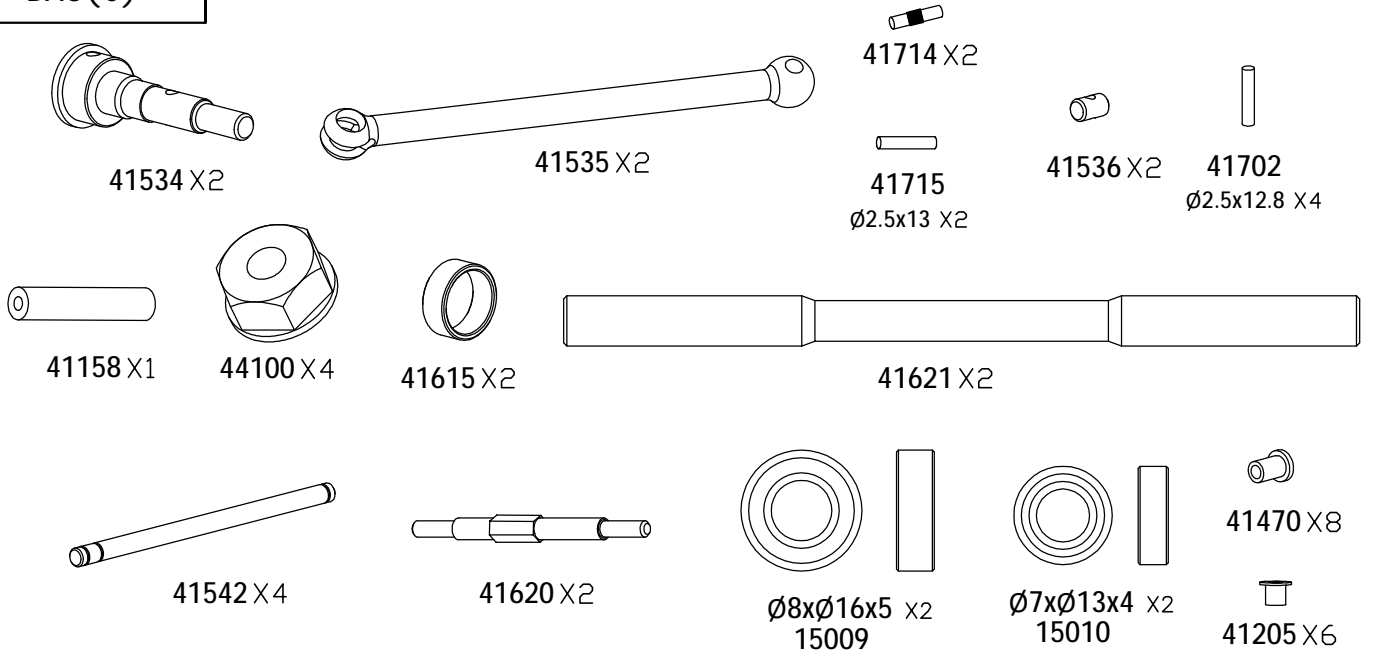

BAG(D)

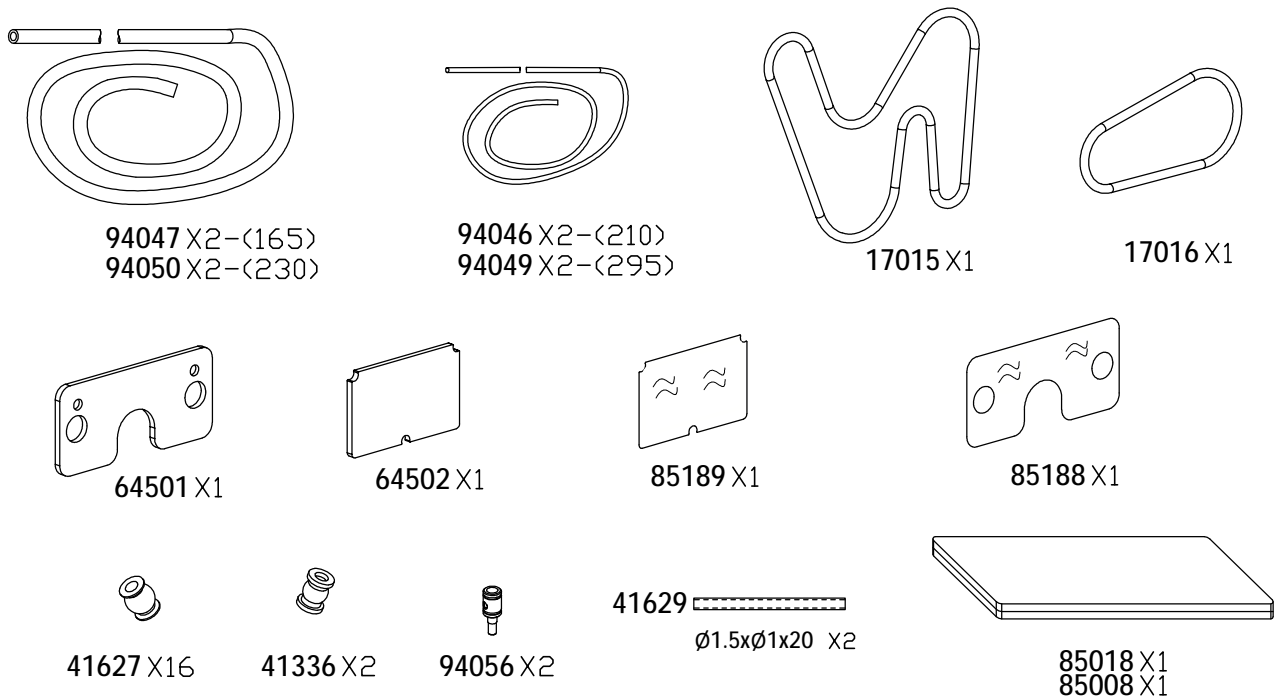

BAG(E)

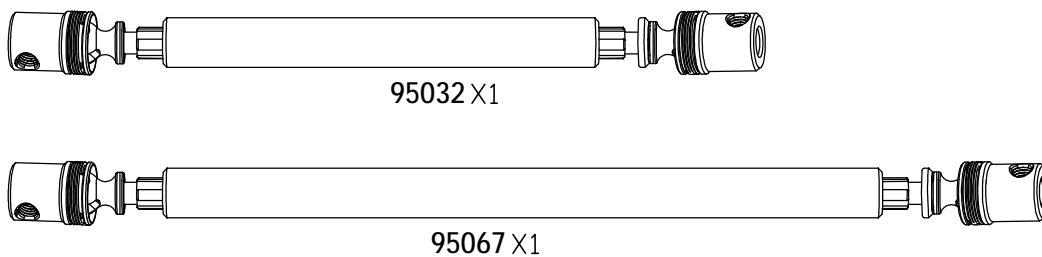

BAG(F)

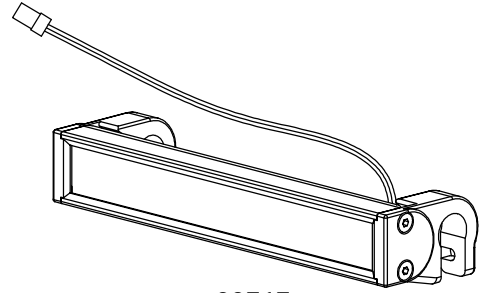
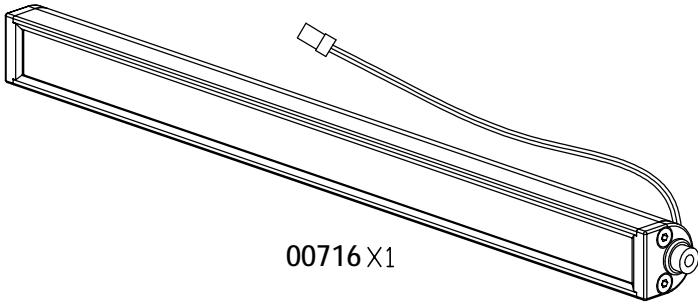

BAG(G)



87095 X1

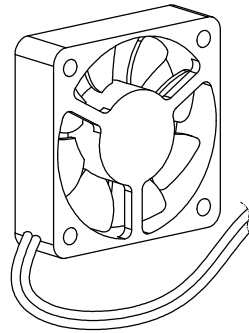

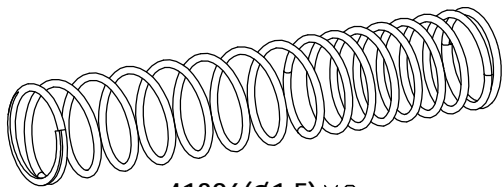
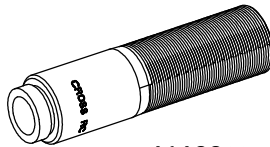
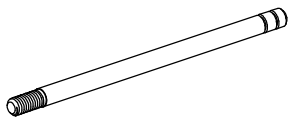

BAG(H)

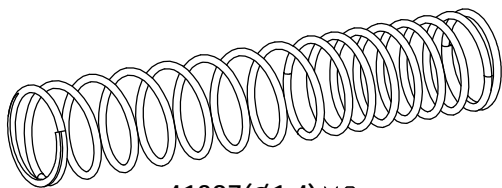

17001 ———
Ø8xØ6xØ1 X4

14109 X4



13003  |
Ø2.5xØ6x0.4 X8

 X4
91128 X4

 X4
91129 X4

BAG(I)

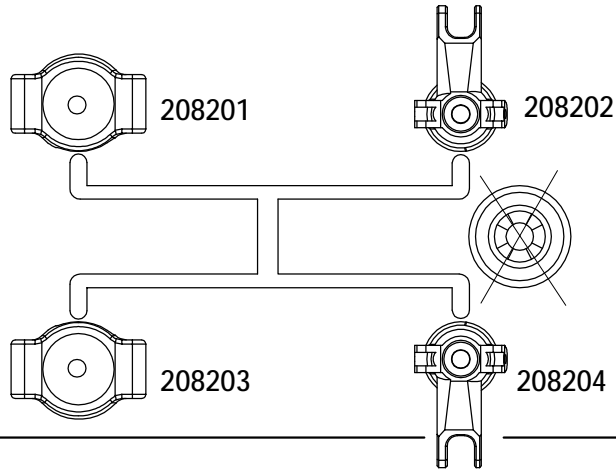

BAG(J)

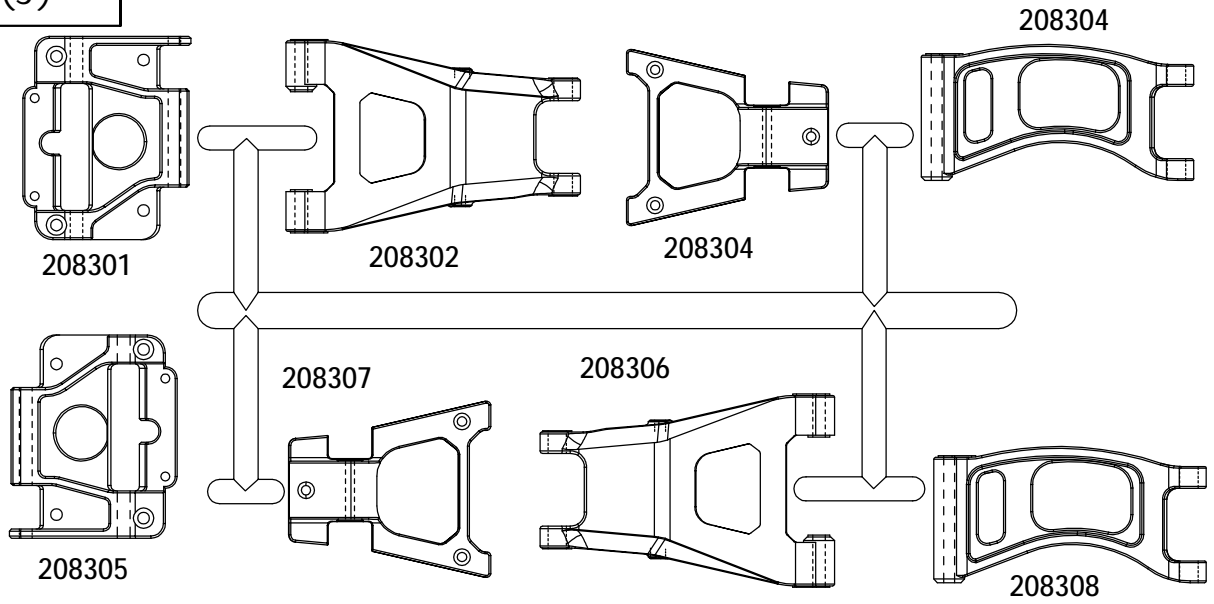

BAG(K)

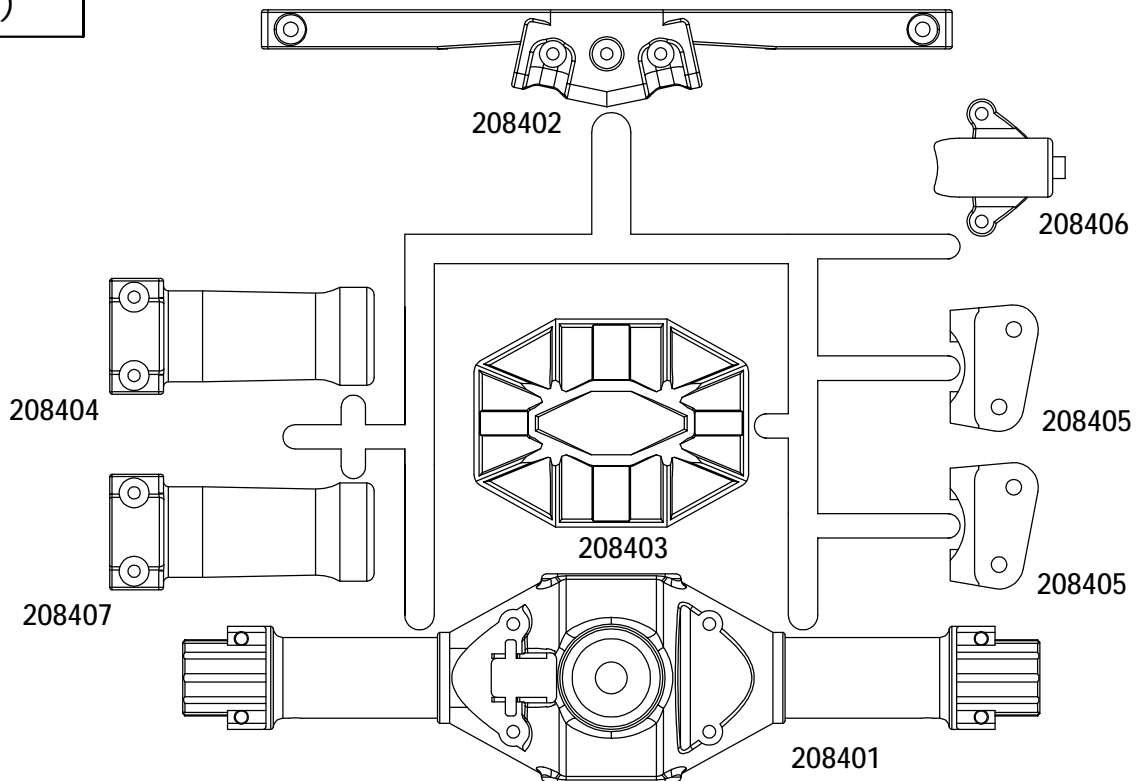

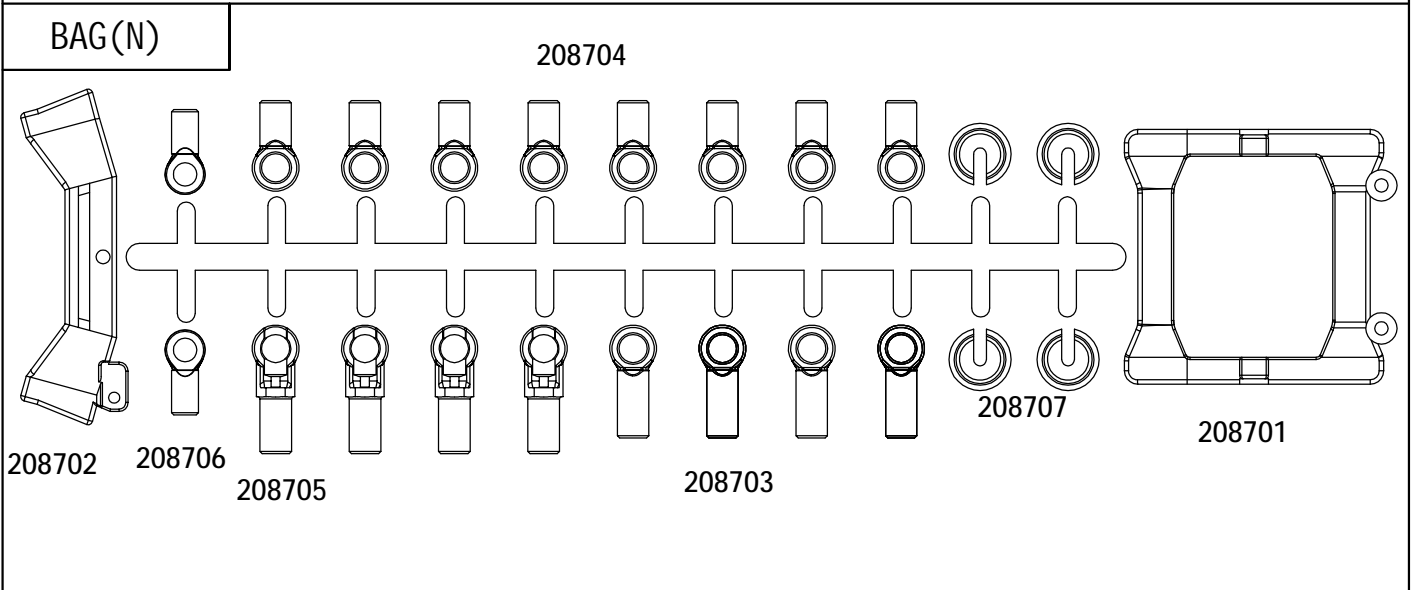
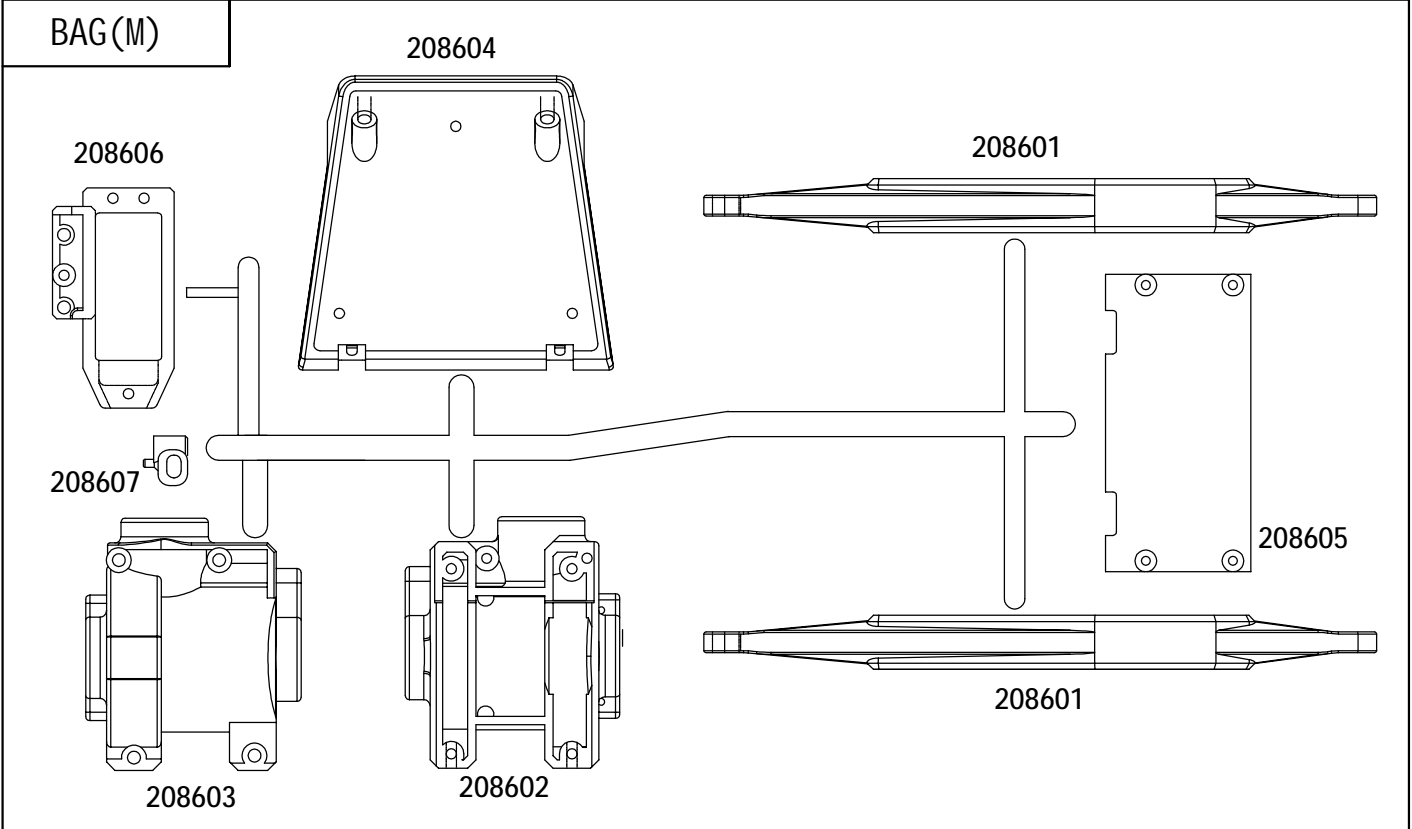
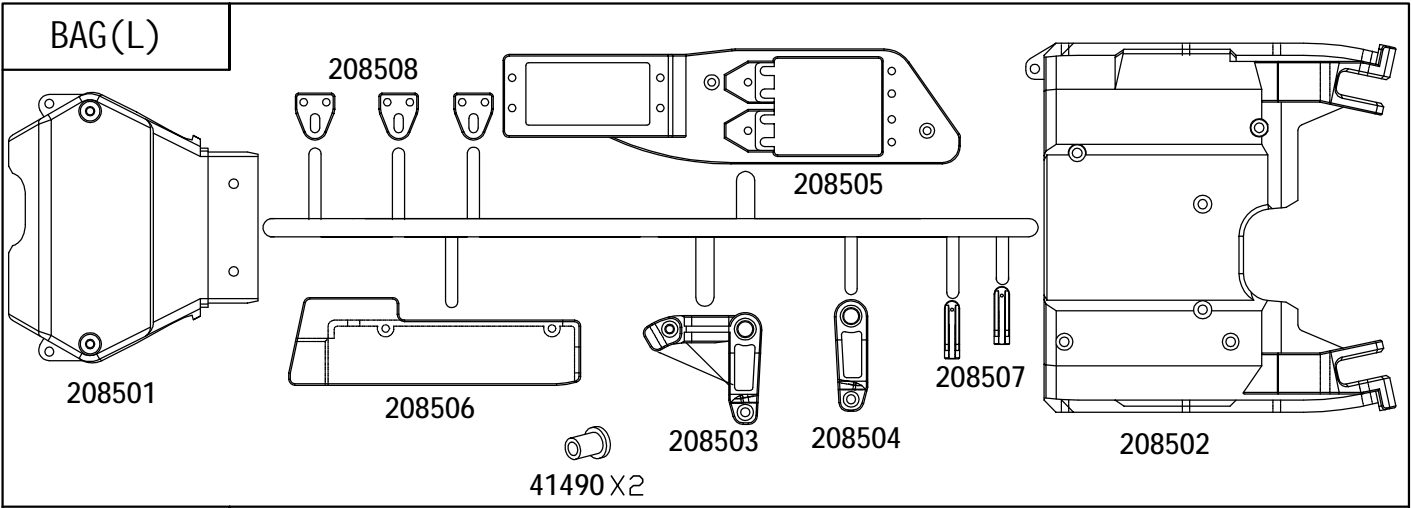

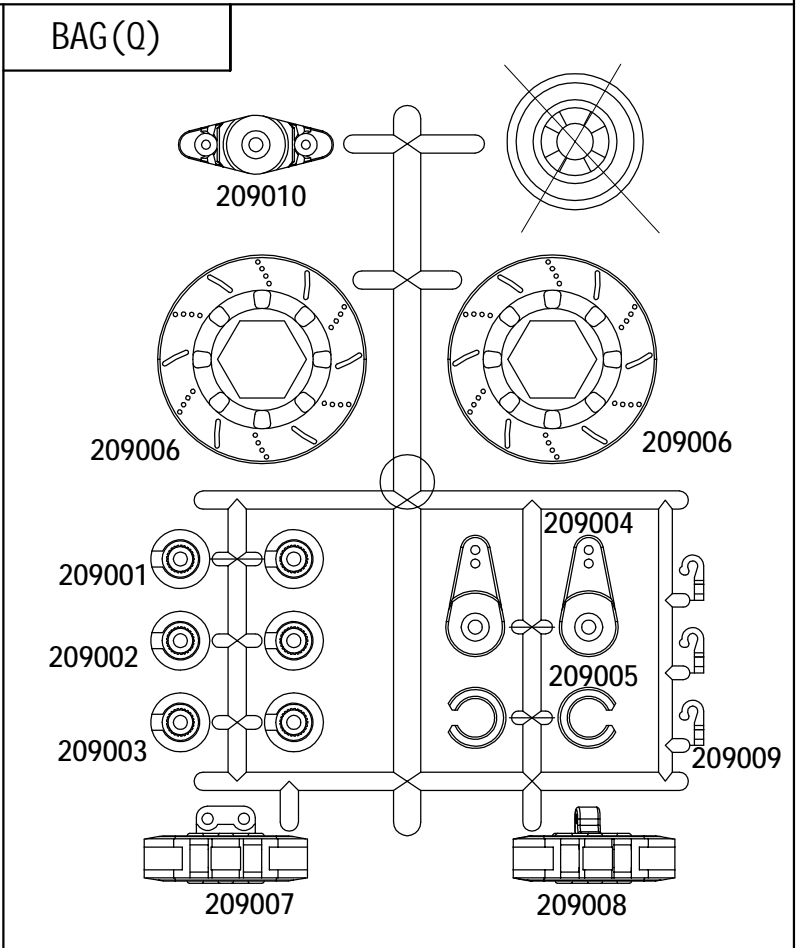
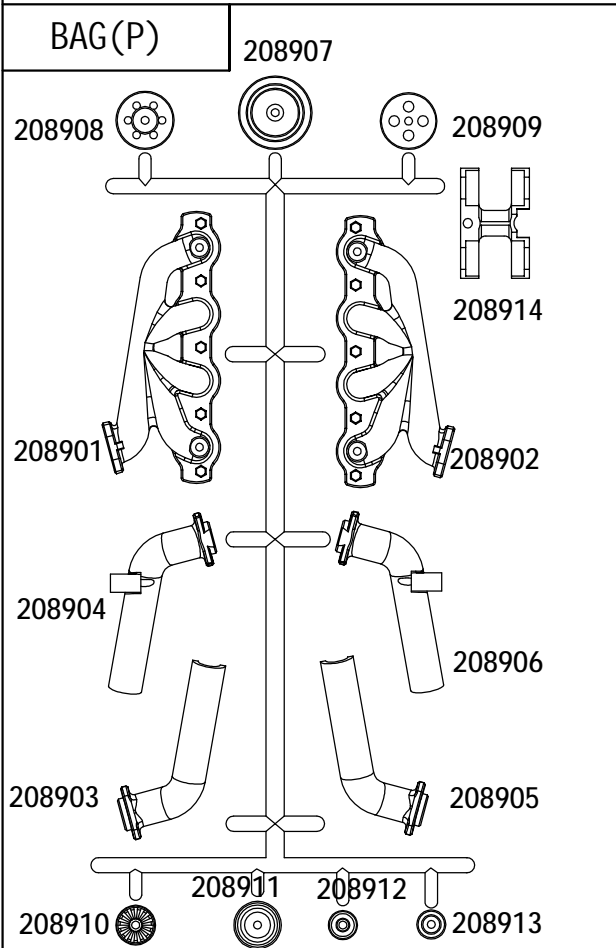
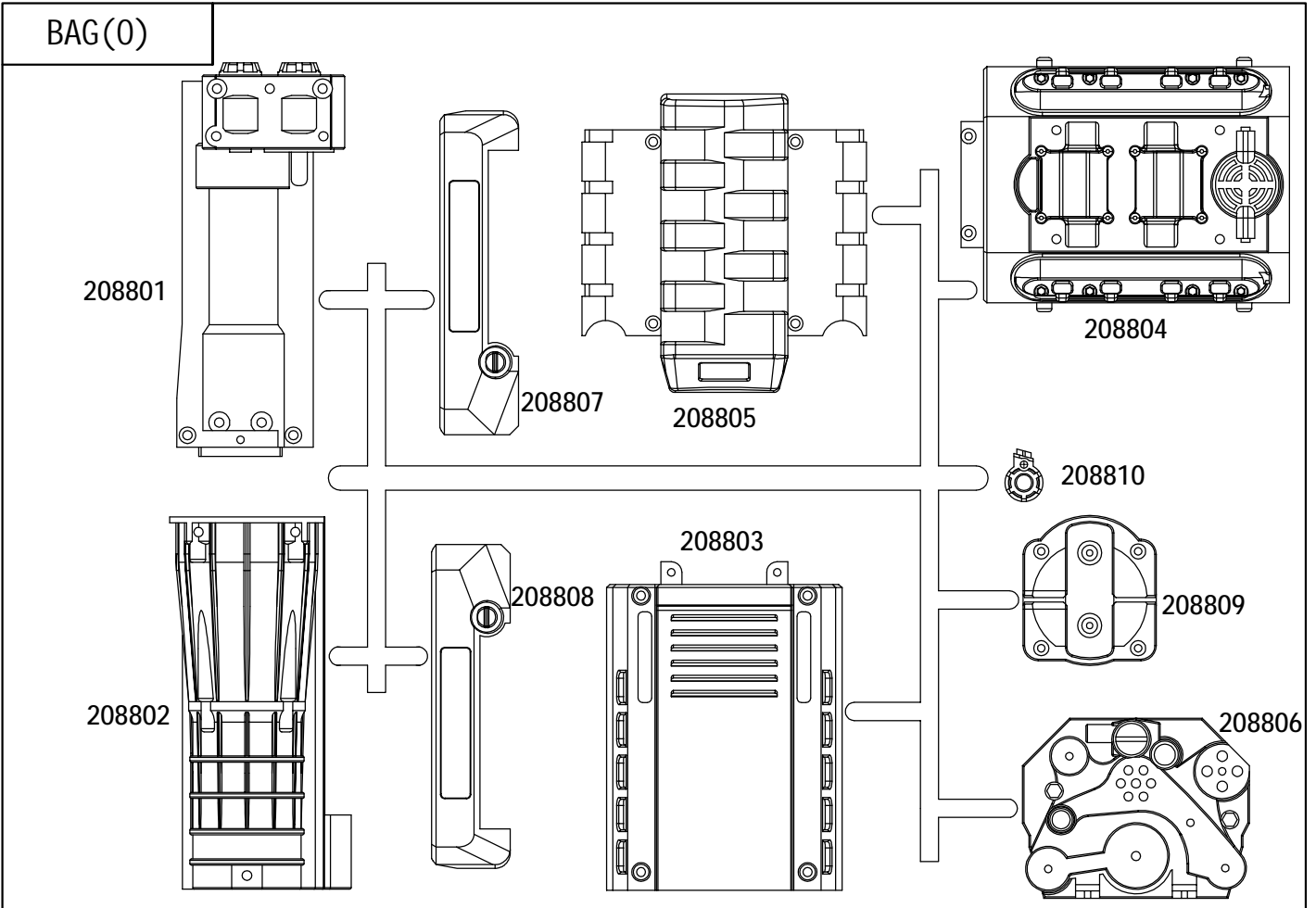

BAG(R)

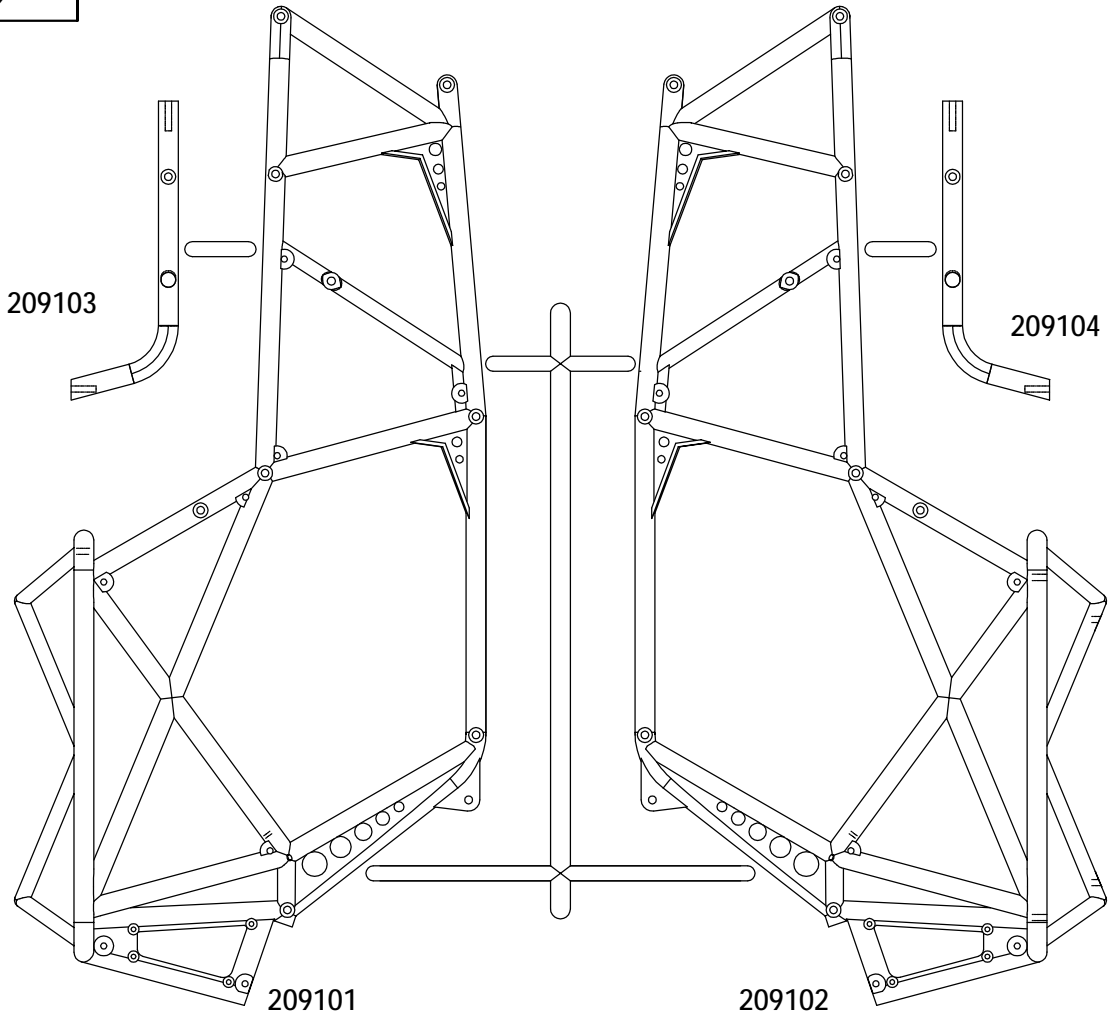

BAG(S)

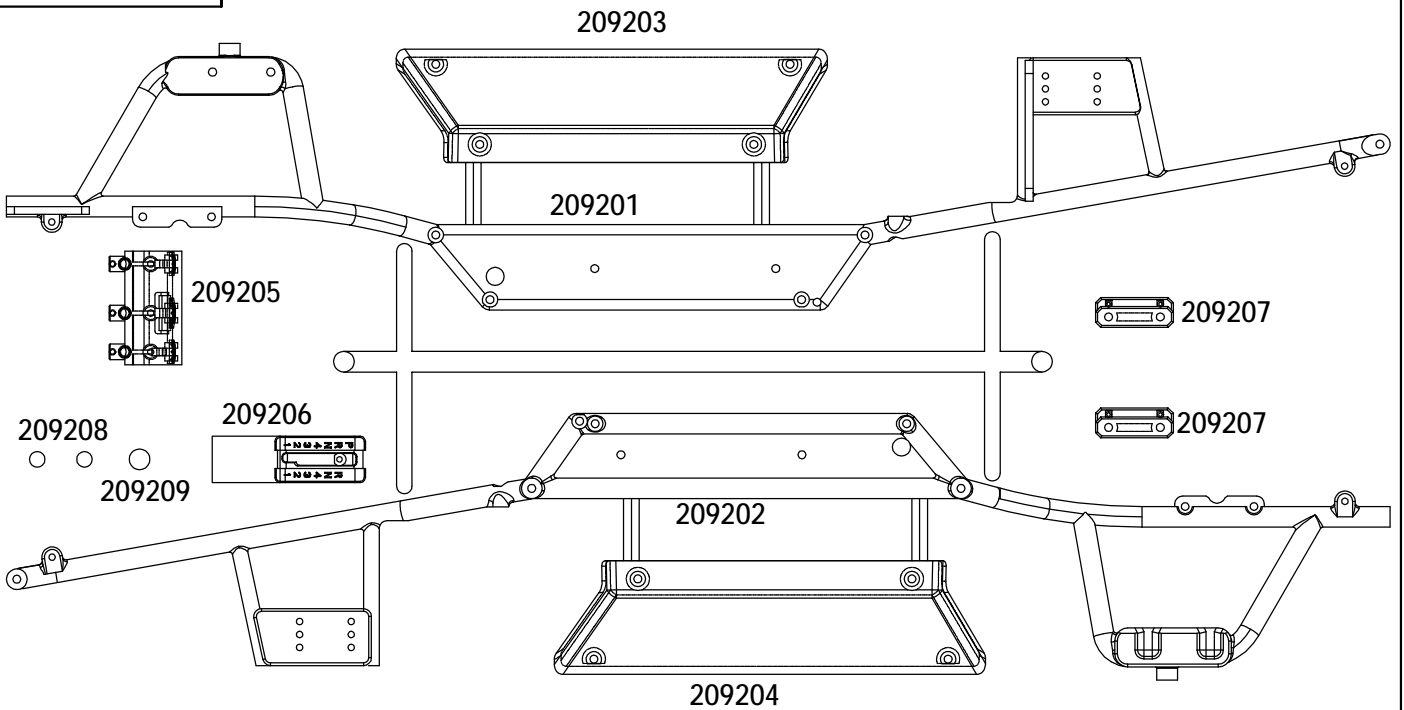

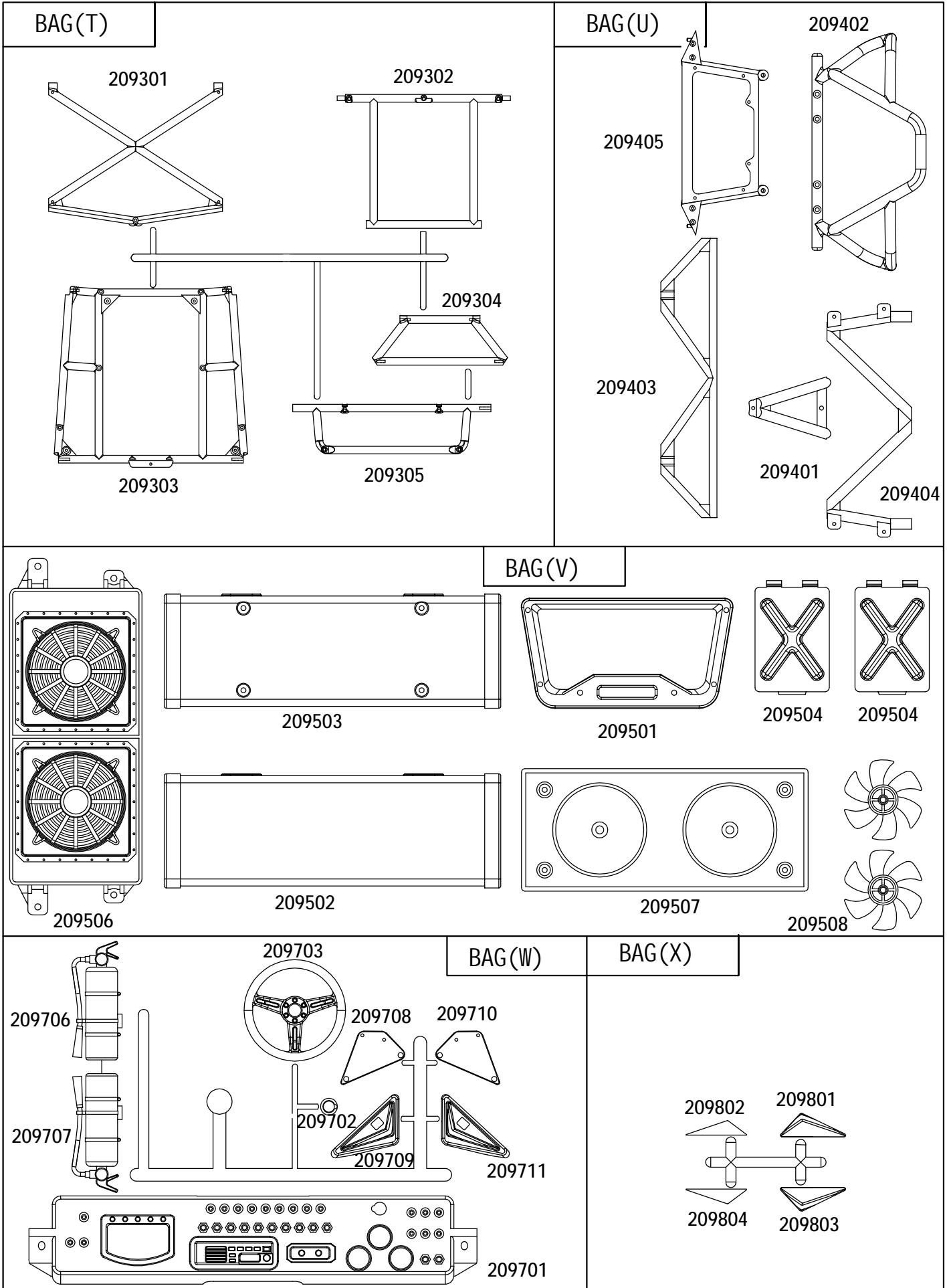

BAG(Y)

209601

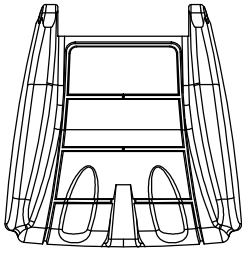

209604

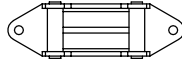

209601

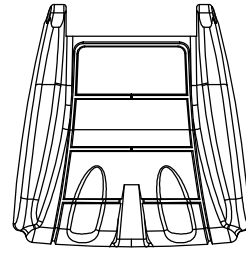

209602

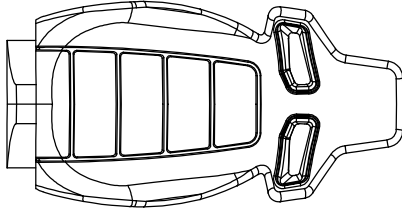

209602

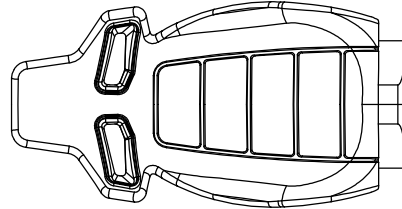

209603

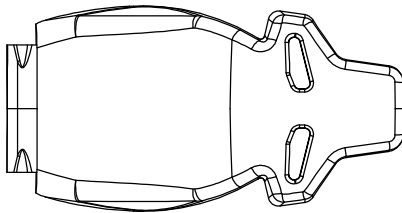

209605



209603

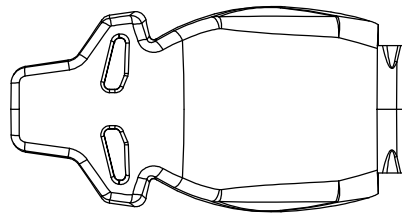

BAG(Z)

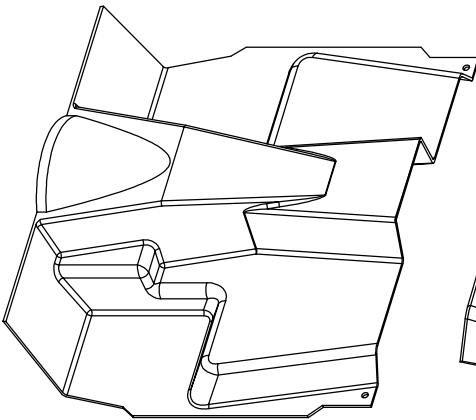

210001 X1

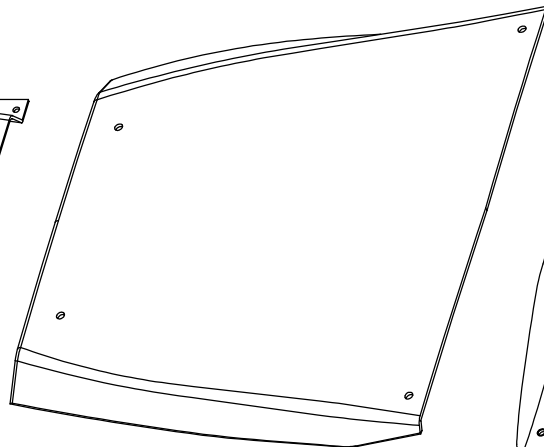

210101 X1

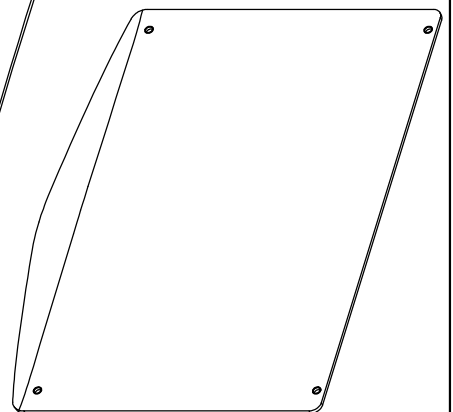

210102 X1

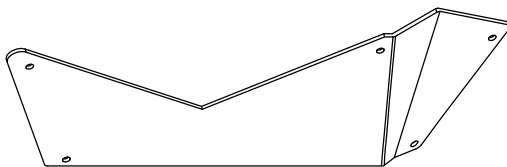

210202 X1

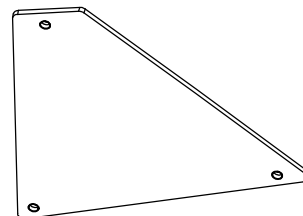



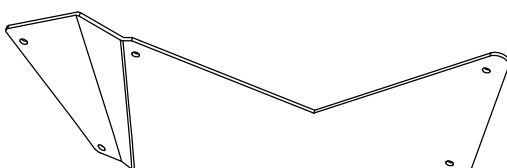



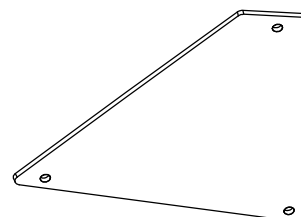





























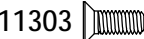



210203 X1



210201 X1







210204 X1

SCREW(A)				
11102  M2x6 X4	11109  M3x14 X8	11110  M3x16 X8	11107  M3x10 X51	
11106  M3x8 X7	11124  M3x32 X4	11105  M3x6 X4	11112  M3x20 X8	
11104  M2x10 X4	11125  M2.5x10 X2	11113  M3x22 X2	11123  M3x45 X2	
SCREW(B)				
11207  M3x10 X4	11229  M3x40 X4	11227  M2.5x8 X20	11210  M3x16 X11	
11205  M3x6 X25	11206  M3x8 X22	11214  M3x25 X3	11211  M3x18 X4	
11228  M2.5x12 X4	11212  M3x20 X2	11223  M3x30 X4		
SCREW(C)				
	11306  M3x10 X6	11307  M3x14 X6	11315  M2.5x6 X6	
	11313  M3x20 X3	11303  M3x8 X5		
SCREW(D)				
11405  M4x4 X4	11407  M3x16 X6	11409  M4x11 X4	13003  Ø2.5xØ6x0.4 X4	14102  Ø3xØ7x0.5 X4
SCREW(E)				
11906  M3x8 X30	11903  M3x10 X16	11904  M3x16 X42	11905  M3x20 X6	
Nut				
12103  M3 X2	12105  M2.5 X2	12206  M2 X2	12203  M3 X39	12305  M5 X4

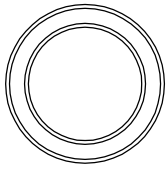
1

11306  M3x10 X4

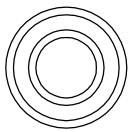
 
 Ø15xØ21x4 X1
 15011

 
 Ø8xØ16x5 X2
 15009







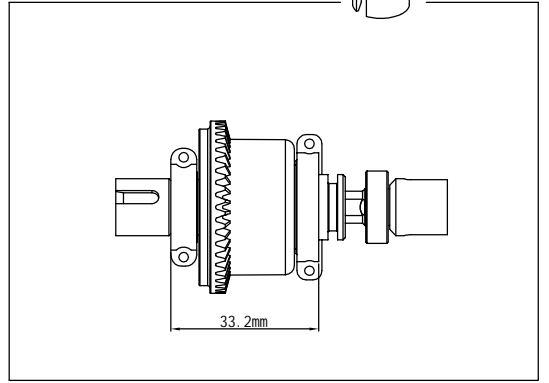
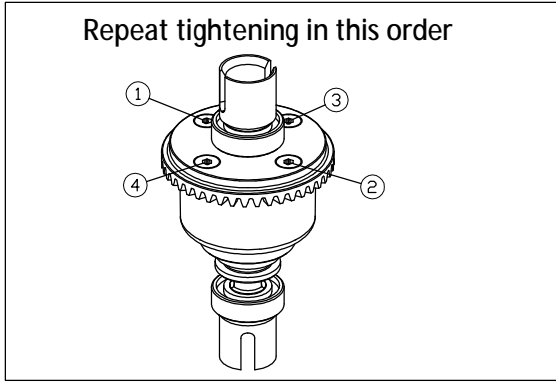
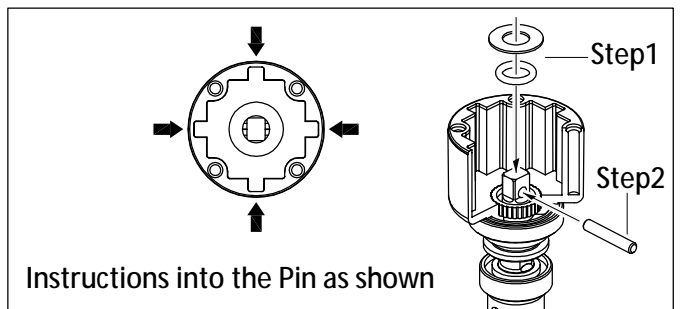
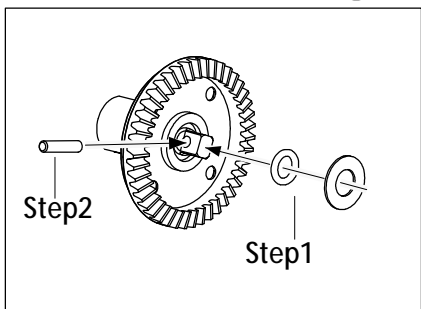
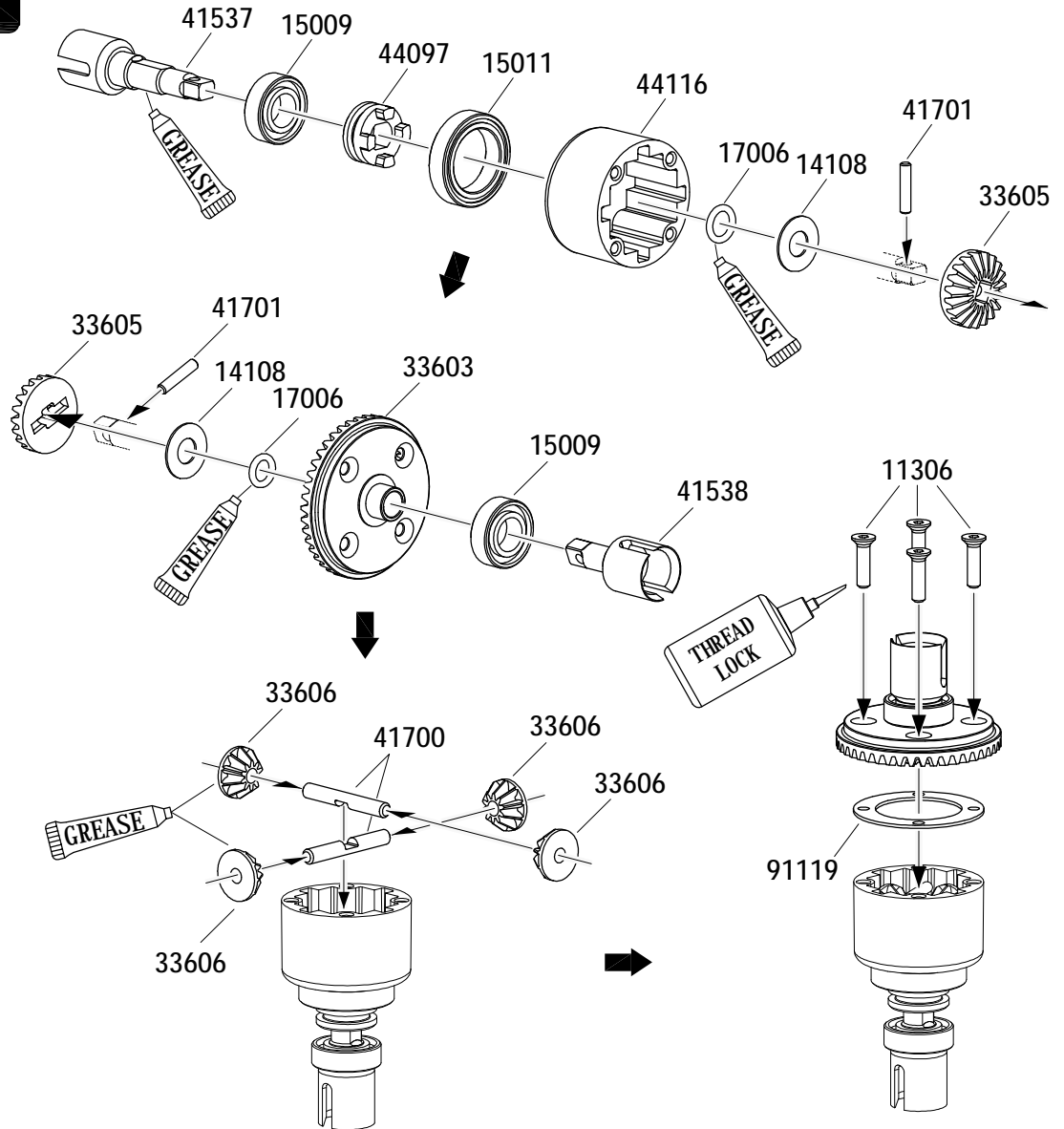



41701  M2.5x12 X2



91007 X1

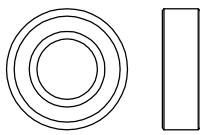

2 Front Differential

- 11401  M3x4 X1
- 11102  M2x6 X4
- 11107  M3x10 X2
- 11109  M3x14 X2
- 11307  M3x14 X1
- 11306  M3x10 X2
-  $\varnothing 8 \times \varnothing 16 \times 5$ X2
15009
- 41703  M3x21 X1
- 13006  $\varnothing 5 \times \varnothing 9.8 \times 0.5$ X1
-  THREAD LOCK
-  GREASE
- 91007 X1

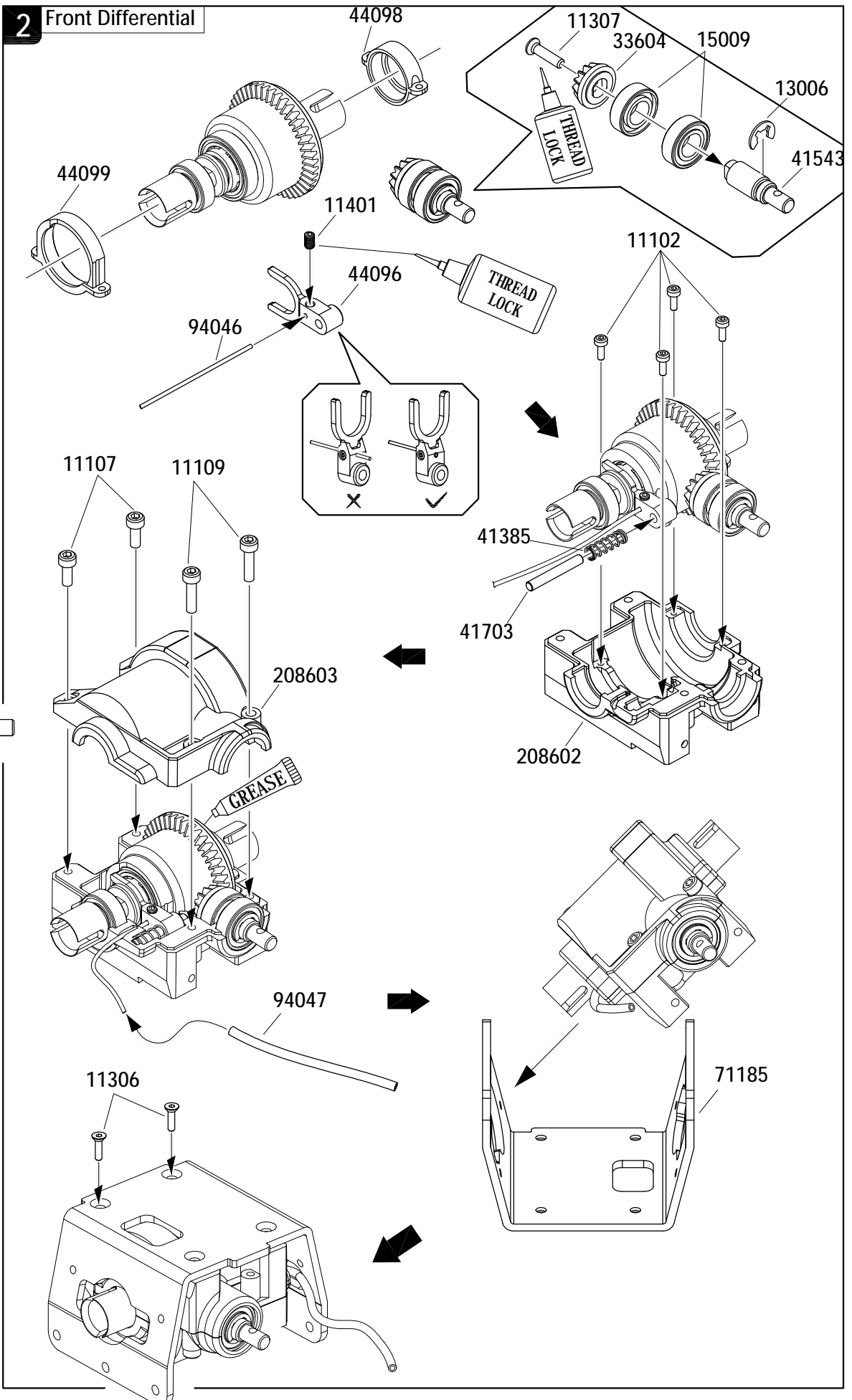

3 LEFT SIDE Assemble both right and left sides

11207 M3x10 X4

Ø8xØ16x5 X2 15009

Ø7xØ13x4 X2 15010

Left:208201 Right:208203

15009 Left:208202 Right:208204

41205 15010

11207 11407

4 LEFT SIDE Assemble both right and left sides

11229 M3x40 X4

11315 M2.5x6 X6

12203 M3 X4

11315

Left:208303 Right:208307

Left:208302 Right:208306

Left:208304 Right:208308

12203

11229 41470

41470 12203

11229 12203

11.6 14.1

5 LEFT SIDE Assemble both right and left sides

41702 M2.5x12.8 X 2

11405 M4x4 X2

41714 41535 41715

41536 41534

41615

41702 11405

44100

6 LEFT SIDE Assemble both right and left sides

Left:208301
Right:208305

13003  $\varnothing 2.5 \times \varnothing 6 \times 0.4 \times 4$

41542

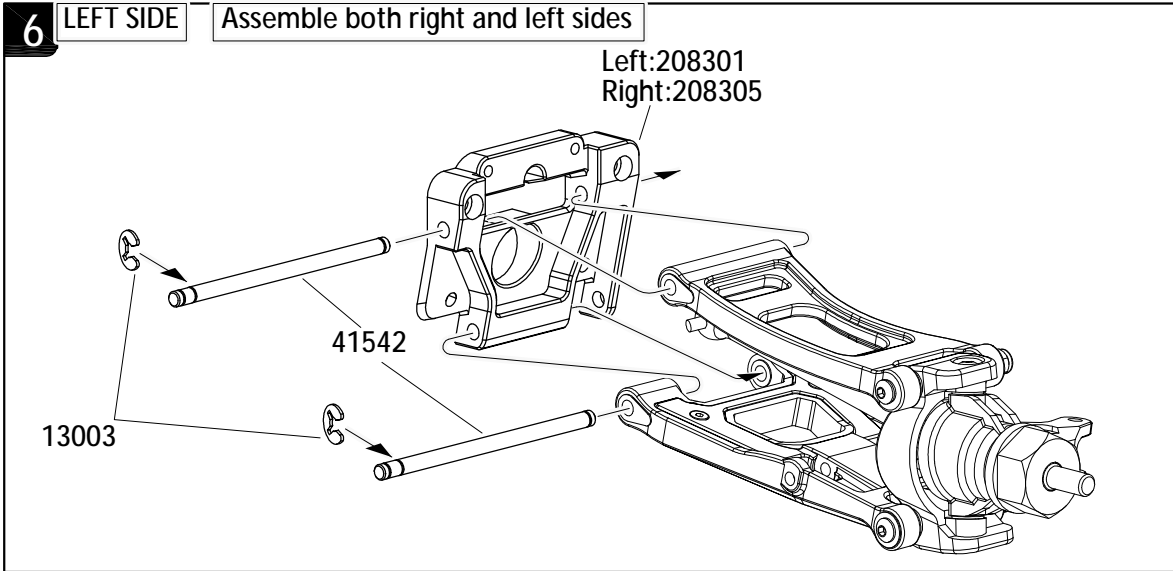

7 LEFT SIDE Assemble both right and left sides

11227  M2.5x8 X2

209006

209008

11227

LEFT SIDE

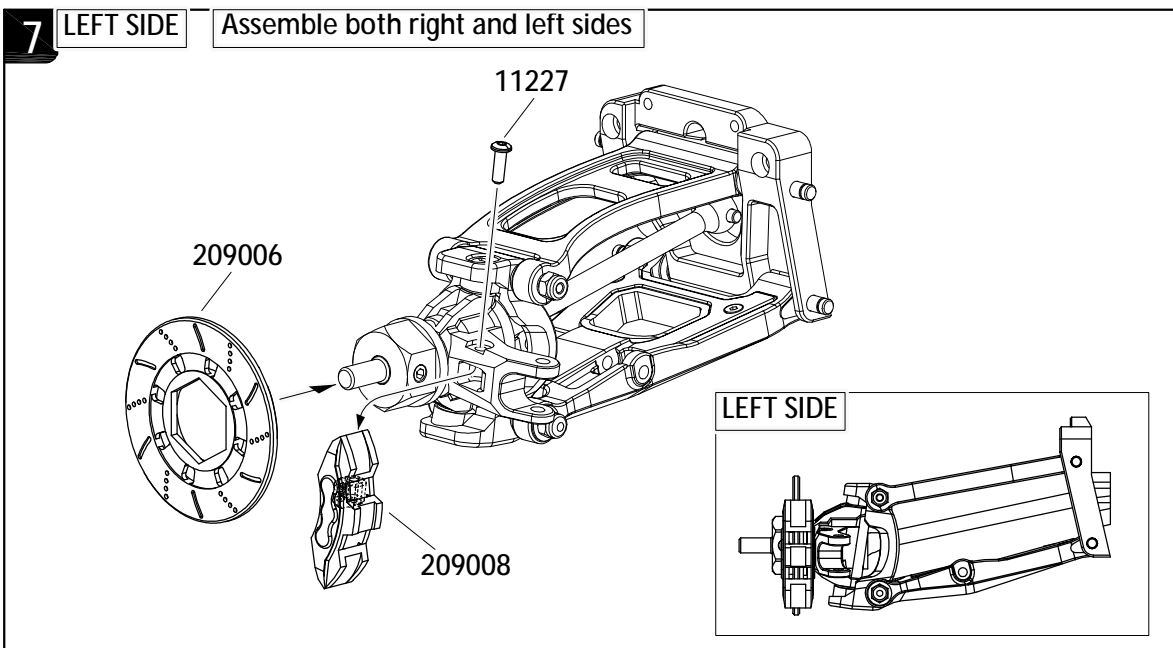

8

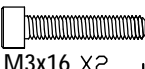
11110  M3x16 X2

41490

208504

208501

208503

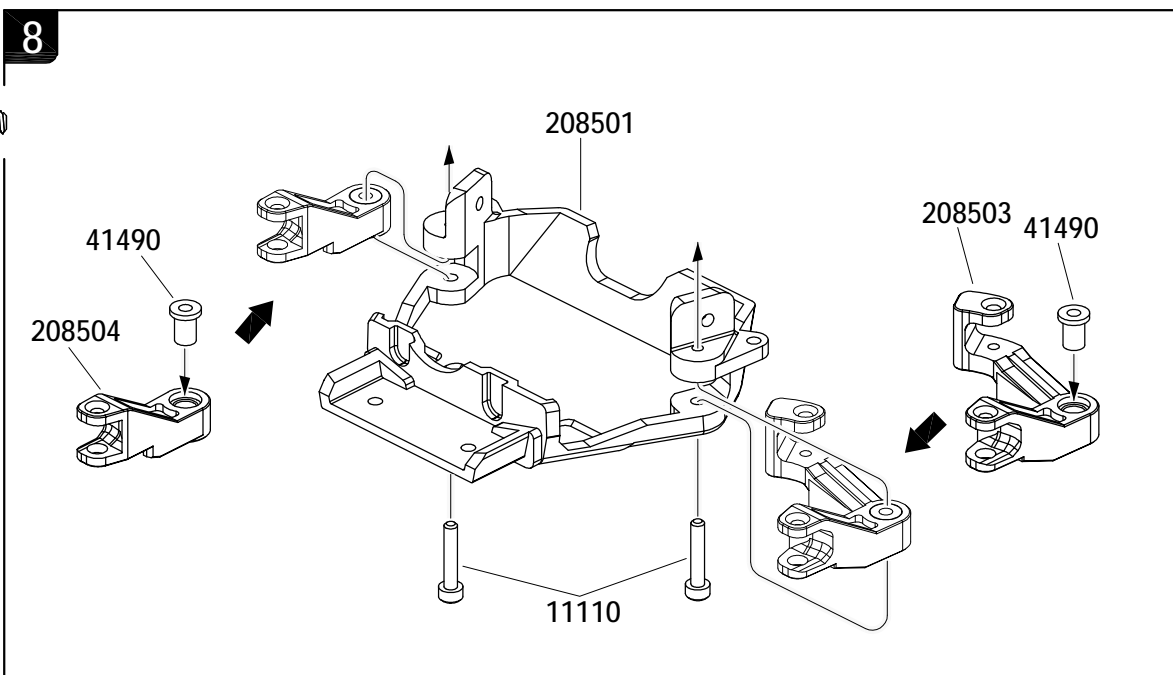

41490

11110

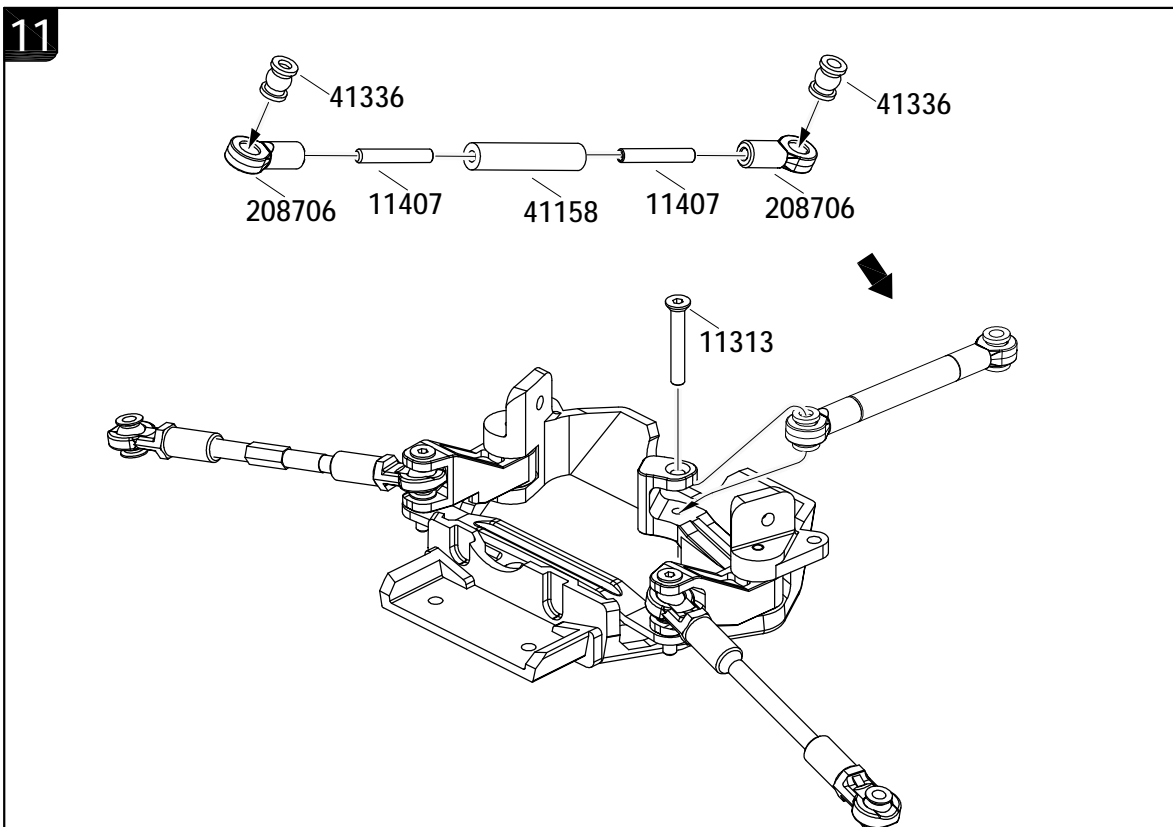
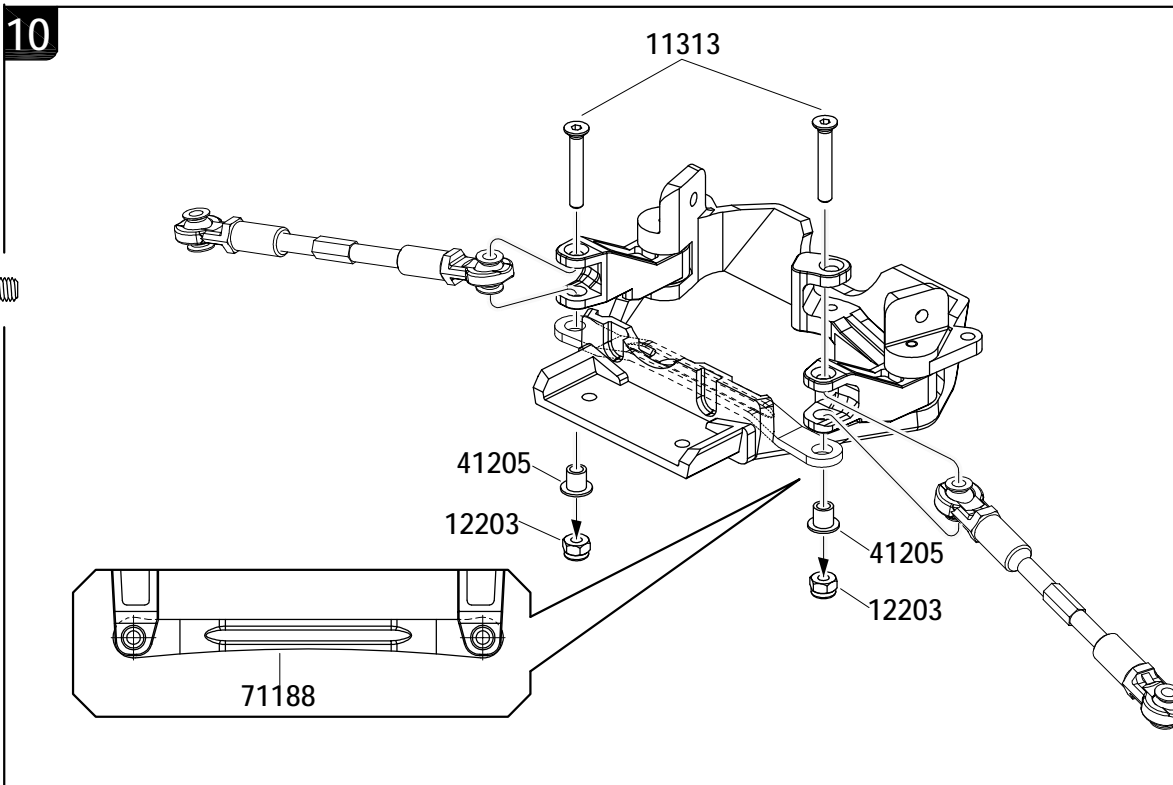
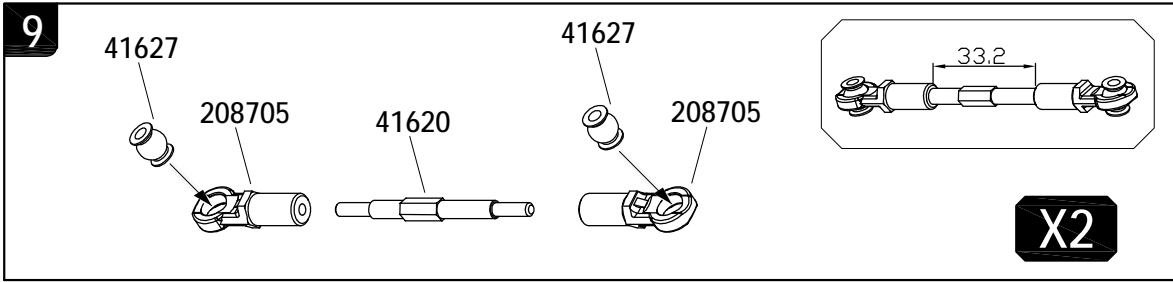



12

- 13006  $\varnothing 5 \times \varnothing 9.8 \times 0.5$ X4
- 41712  $\varnothing 2.5 \times 8$ X1

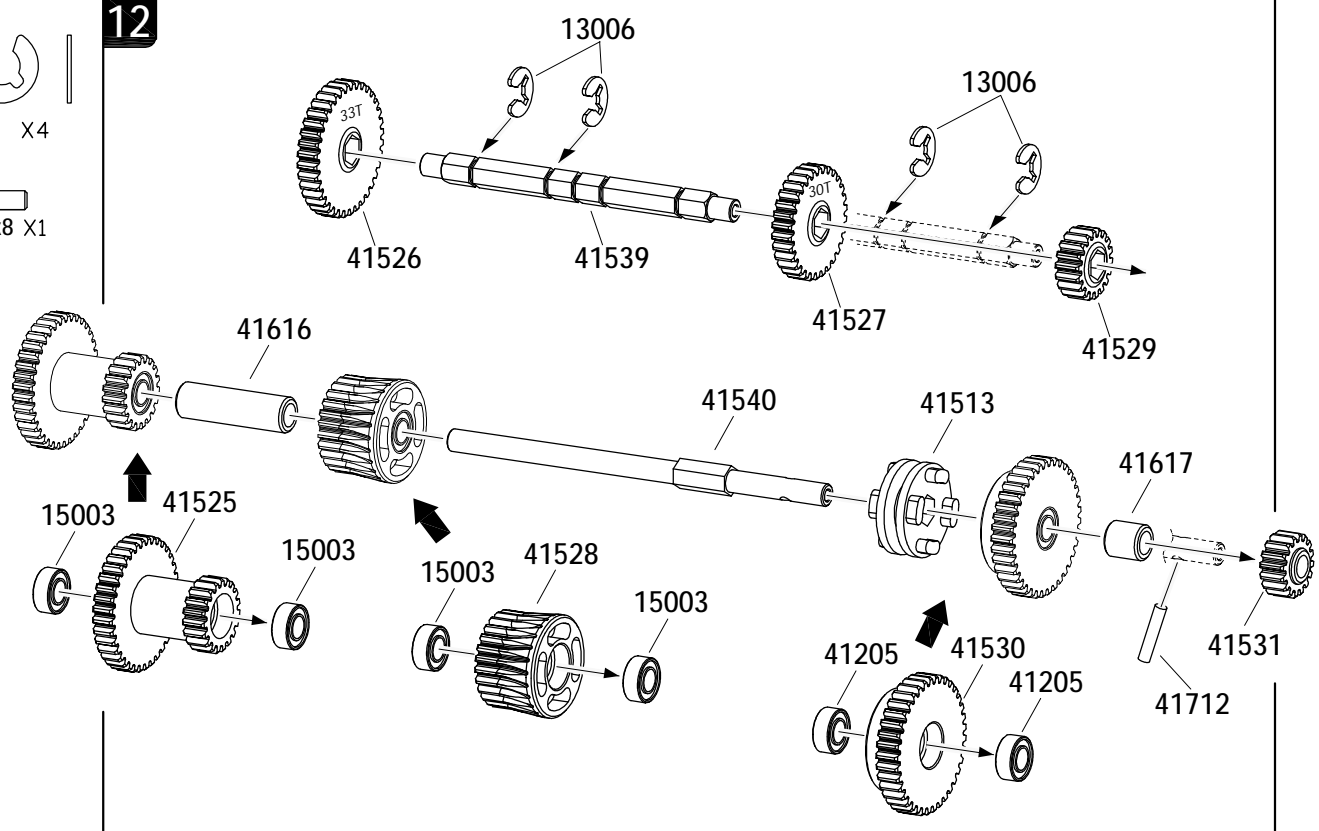



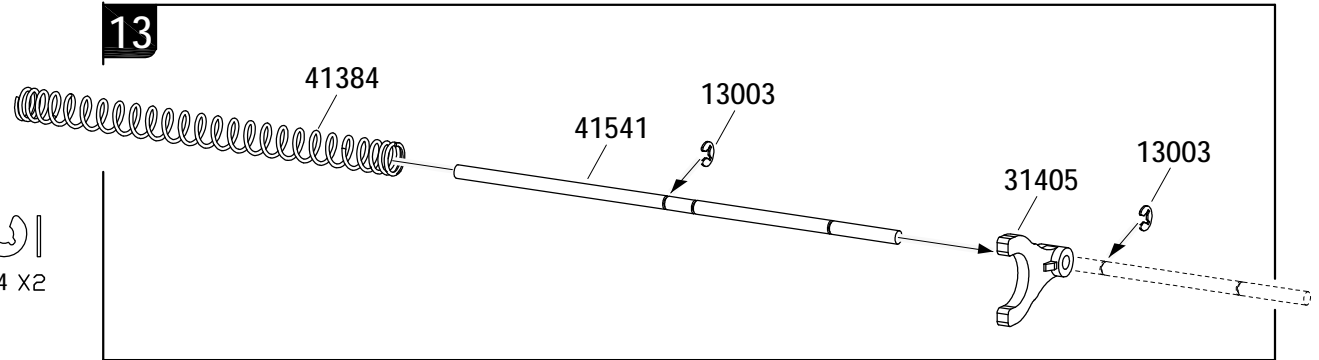

13

- 13003  $\varnothing 2.5 \times \varnothing 6 \times 0.4$ X2

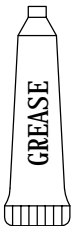

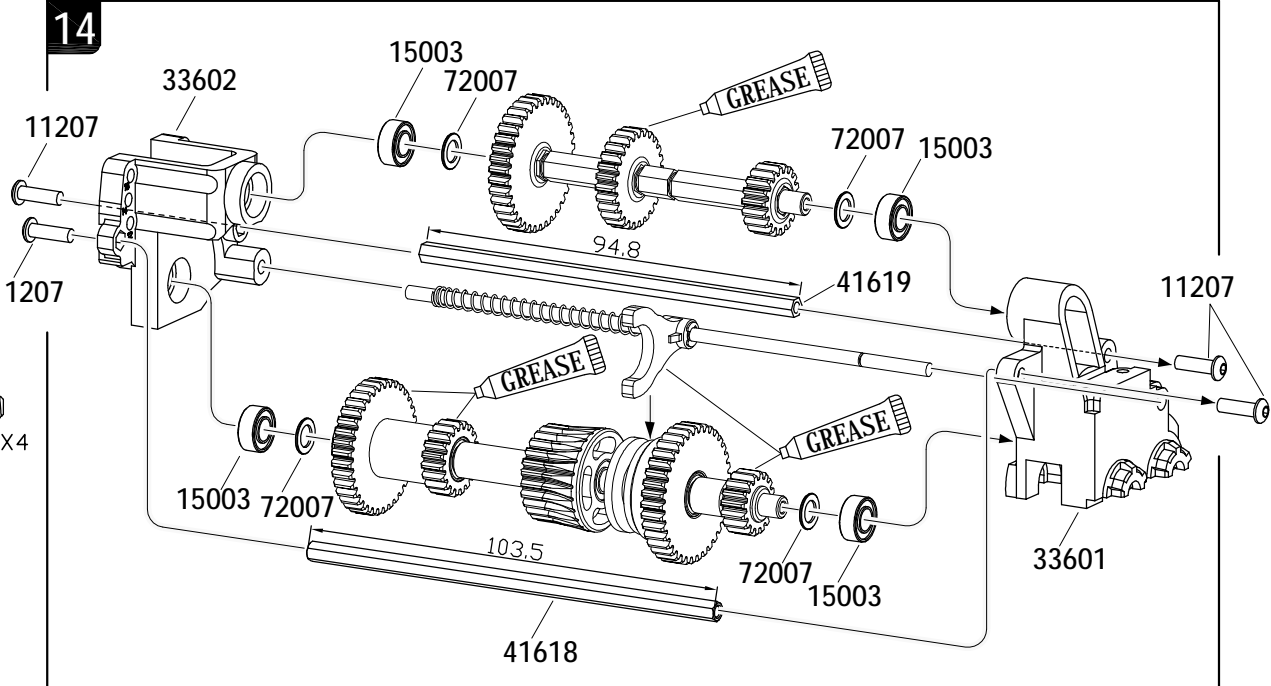

14

-  GREASE
- 91007 X1 
- 11207  M3x10 X4
-  $\varnothing 5 \times \varnothing 10 \times 4$ X10
- 15003 



13003 
 Ø2.5xØ6x0.4 X1

11227 
 M2.5x8 X1

11210 
 M3x16 X5



91007 X1

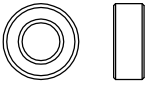

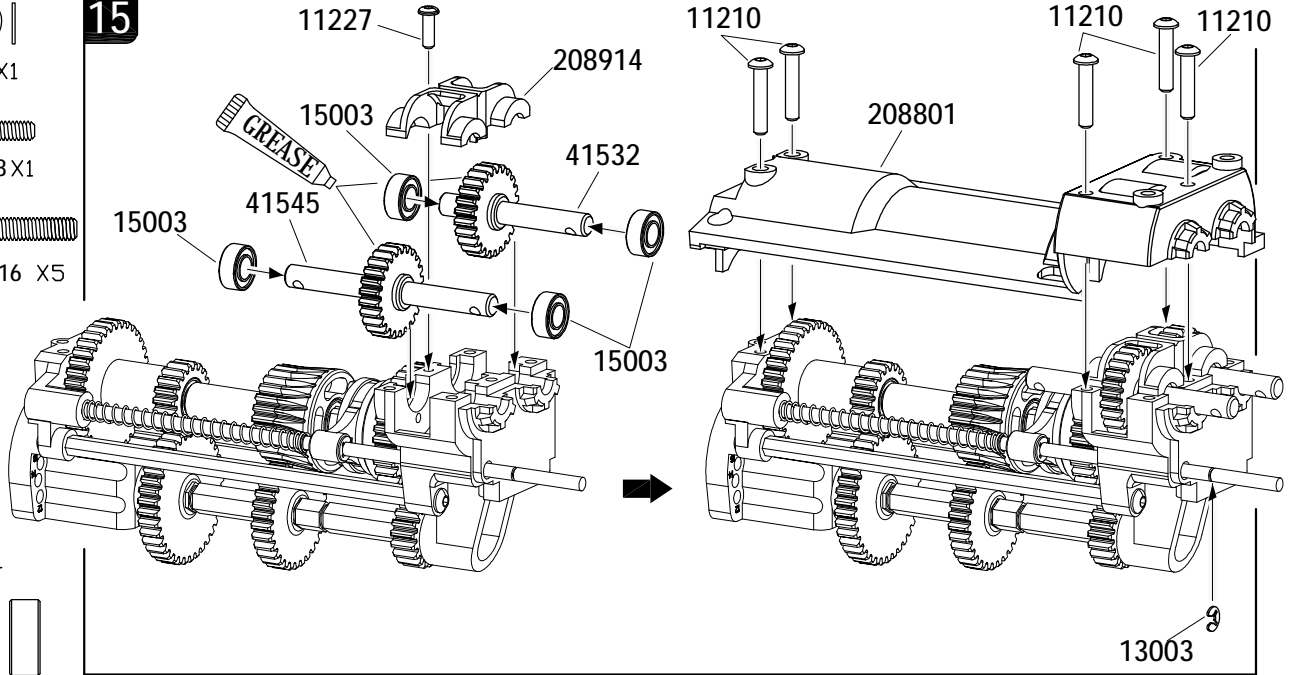

15



Ø5xØ10x4 X4
 15003

11205 
 M3x6 X5

11227 
 M2.5x8 X1

11107 
 M3x10 X1

16

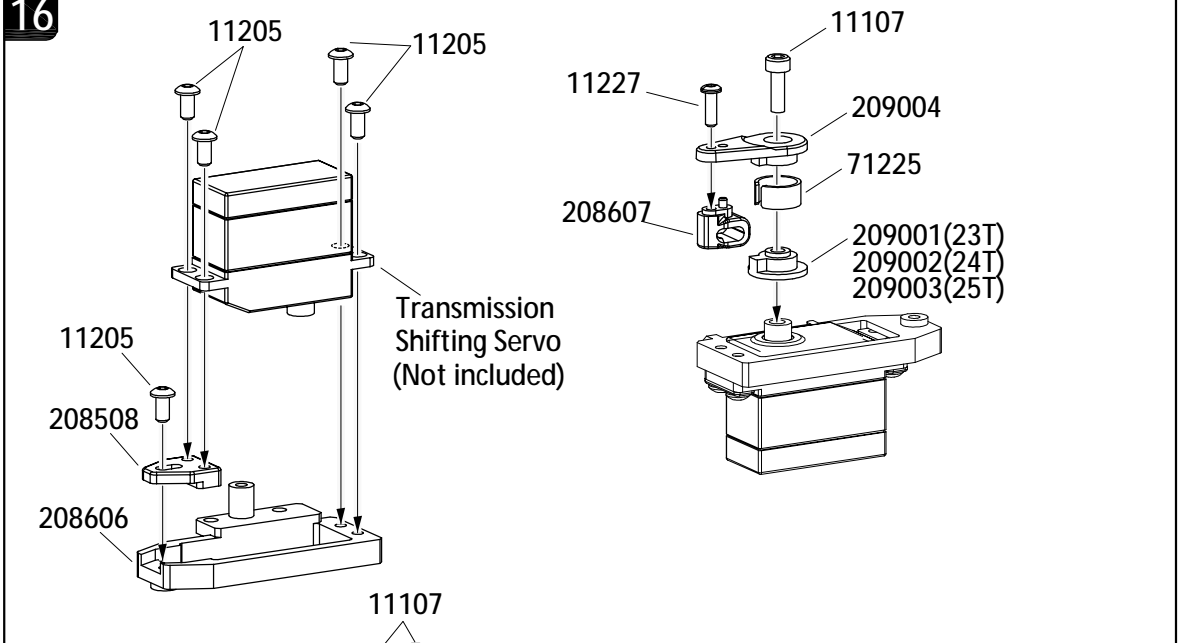

11107 
 M3x10 X2

11227 
 M2.5x8 X1

17

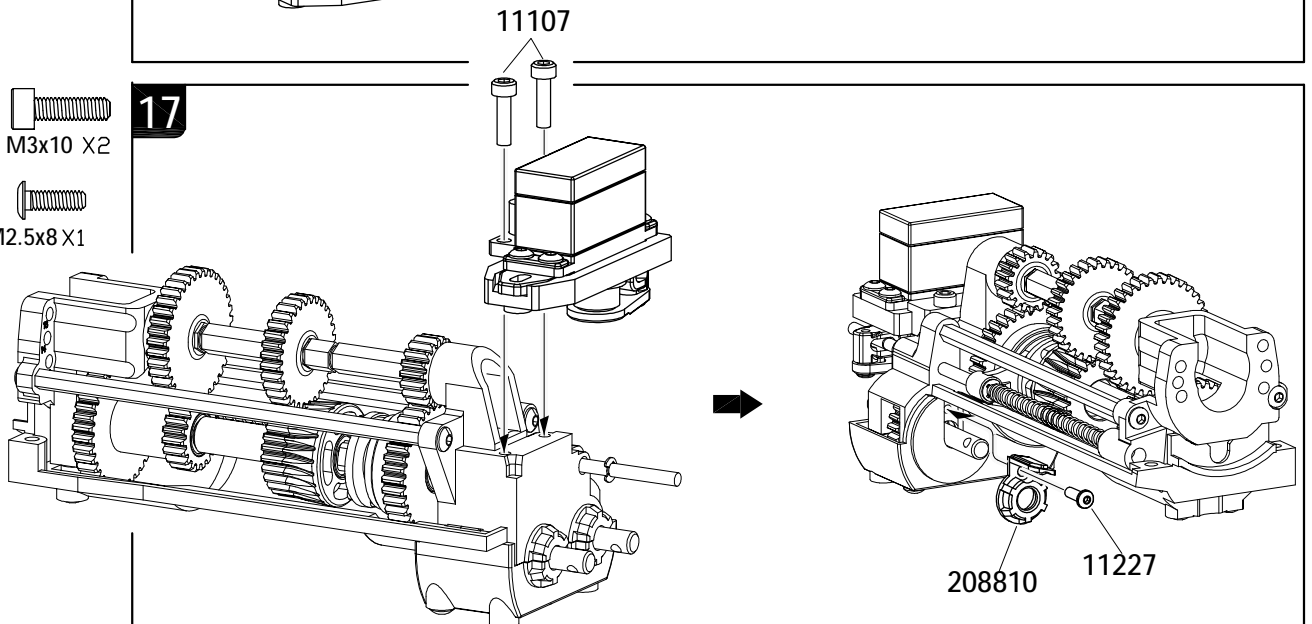

18

11107 
M3x10 X2

11405 
M4x4 X1

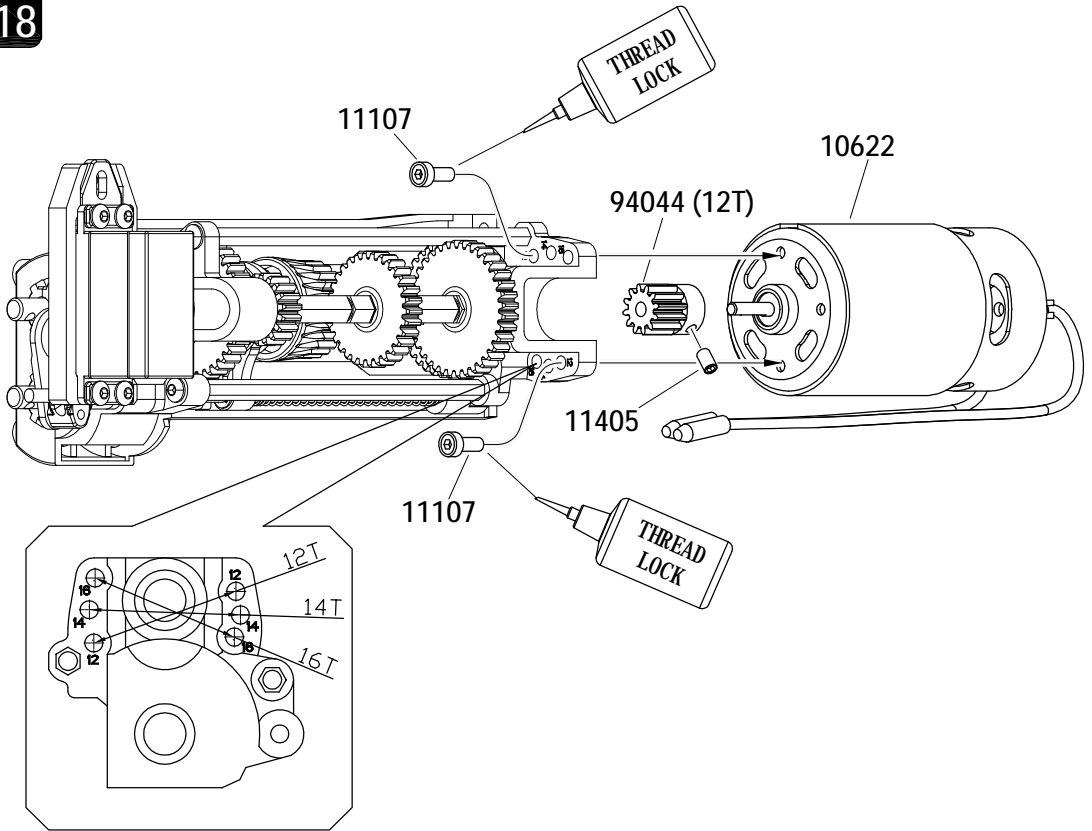

19

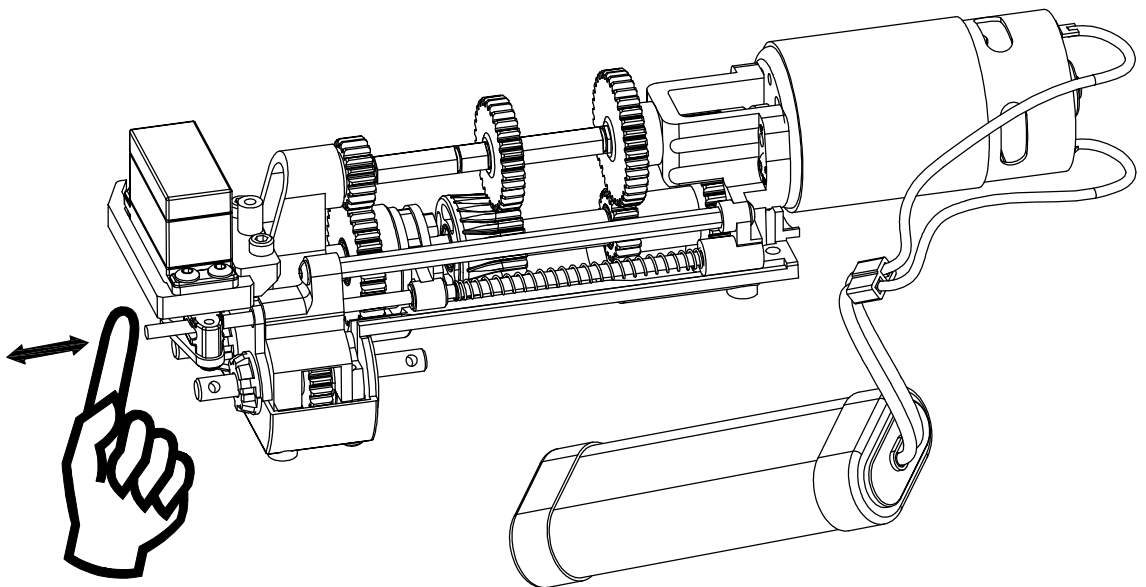

NOTE:

Get power test after assembly finish and adjust gear meshing clearance for make sure gear box running smooth without noise, then process to following assembly go on.

20

11210  M3x16 X6

11227  M2.5x8 X5

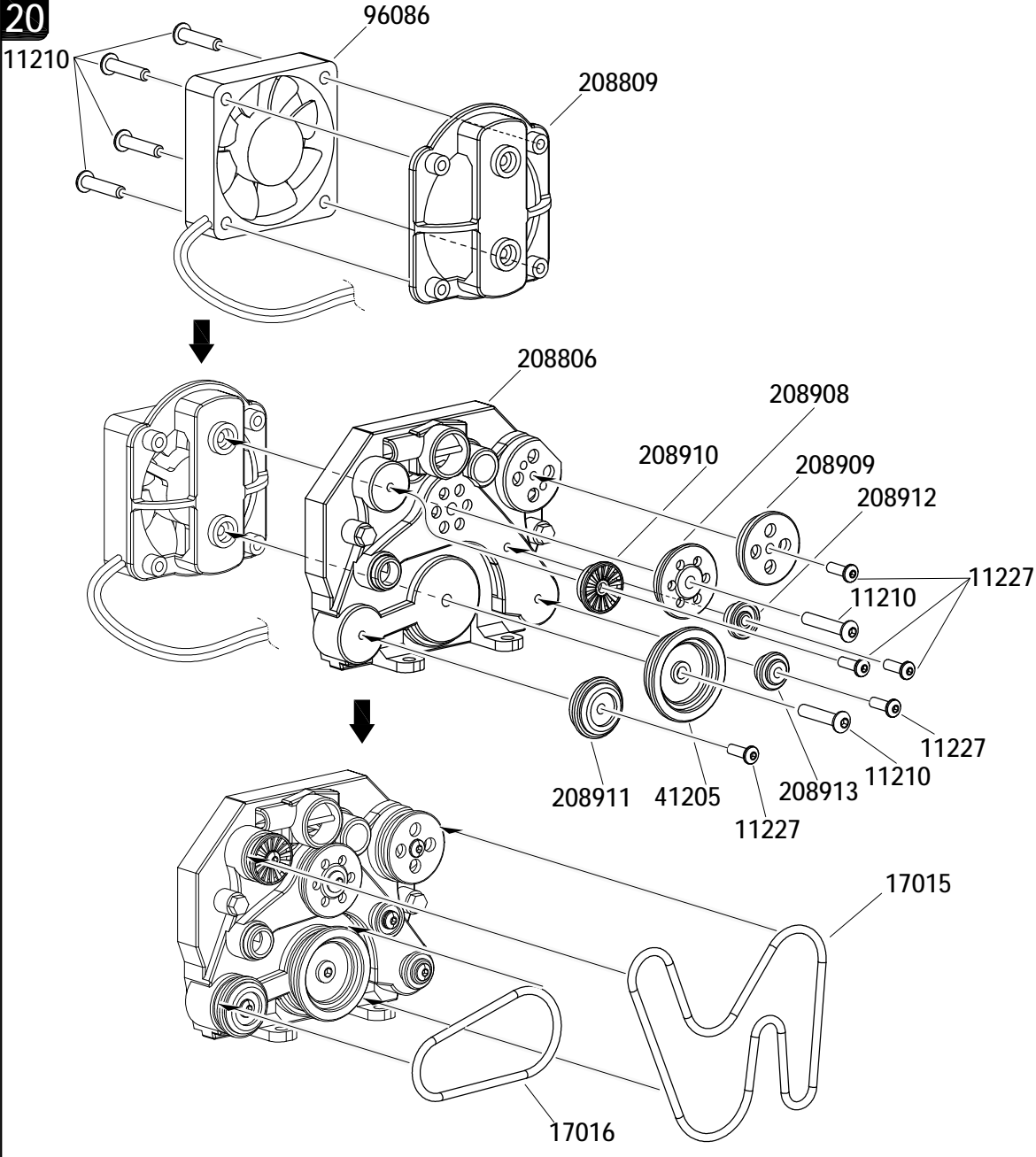

21

11205  M3x6 X4

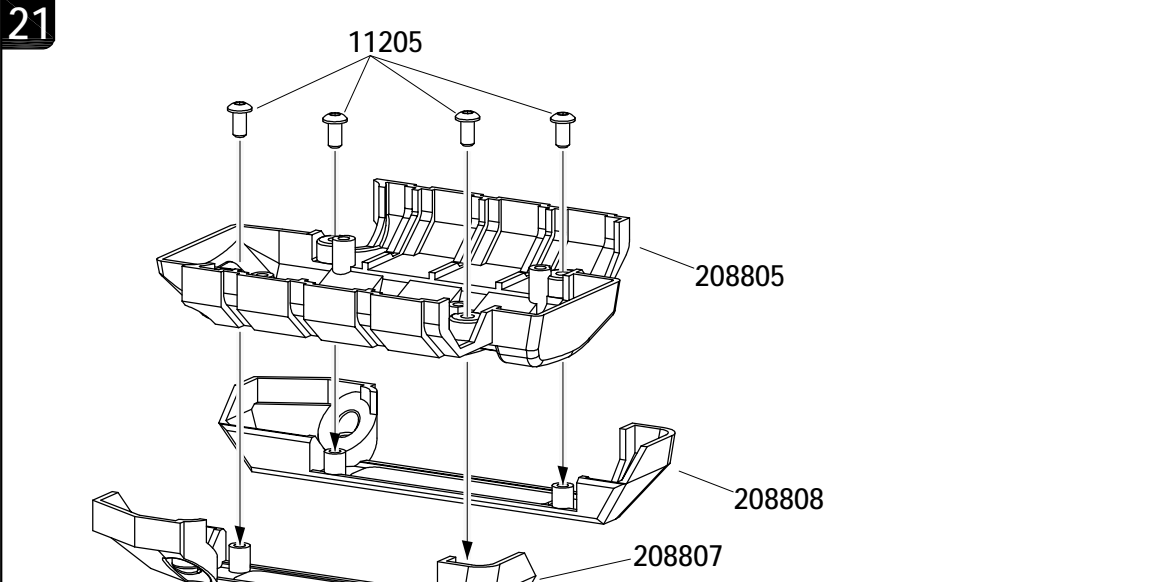

22

11106 
M3x8 X4

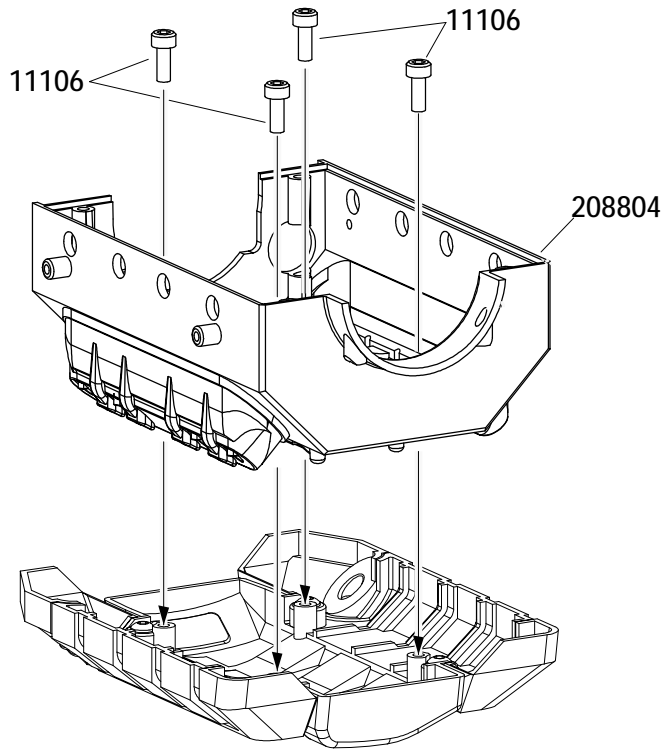
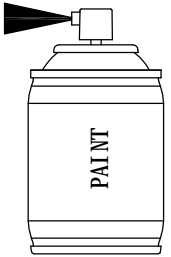

23

11124 
M3x32 X2

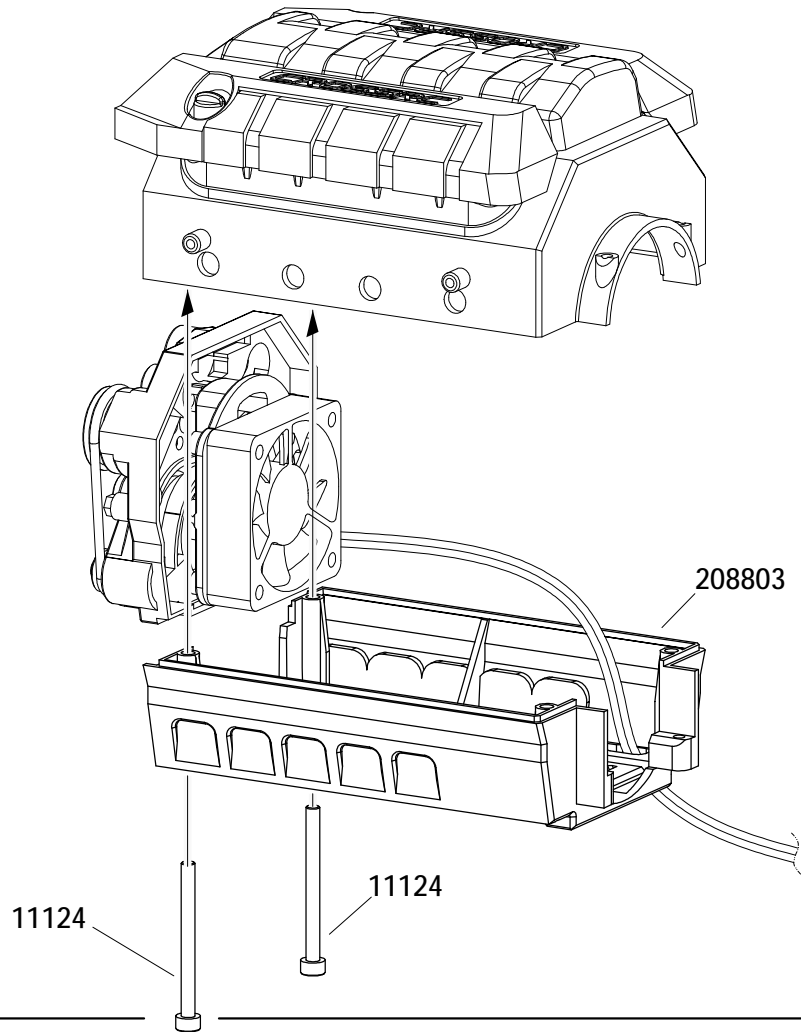

22

11227 
M2.5x8 X4

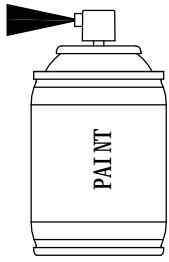

24

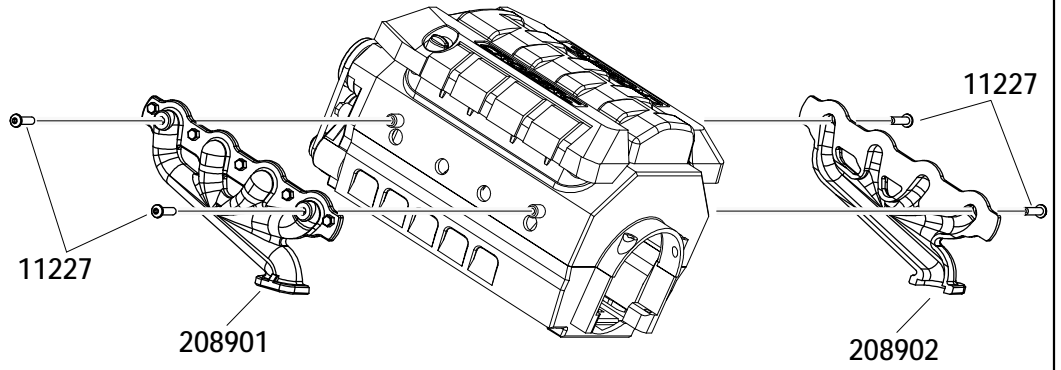

25

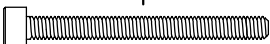
11124 
M3x32 X2

11109 
M3x14 X2

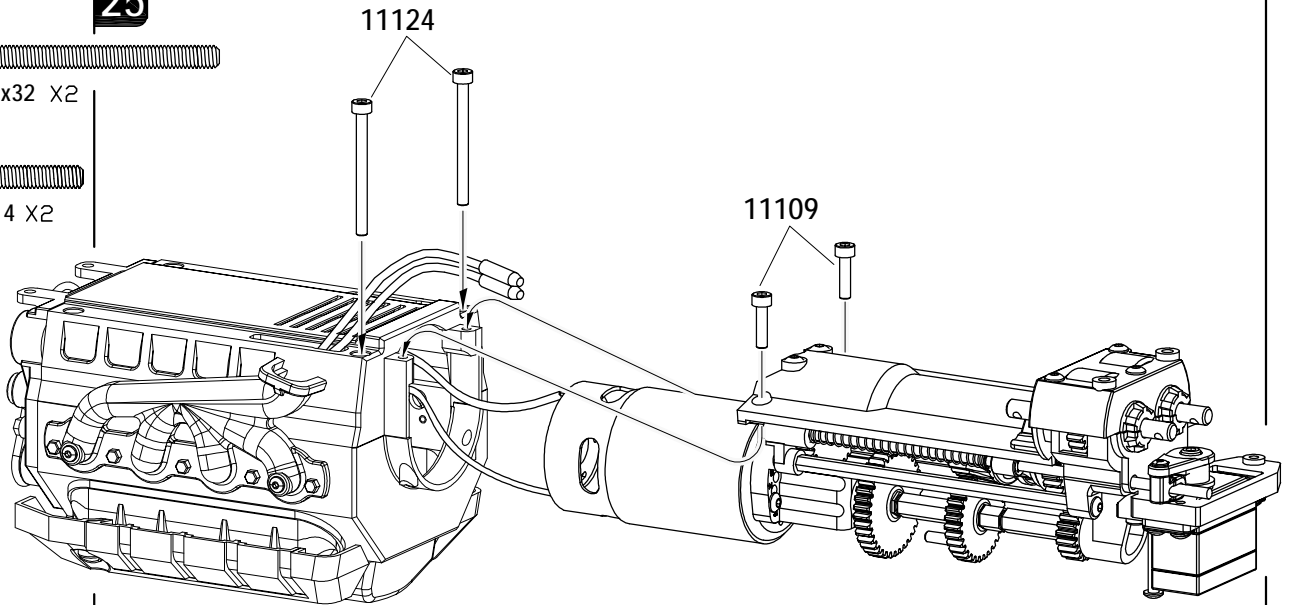

26

11214 
M3x25 X1

11206 
M3x8 X2

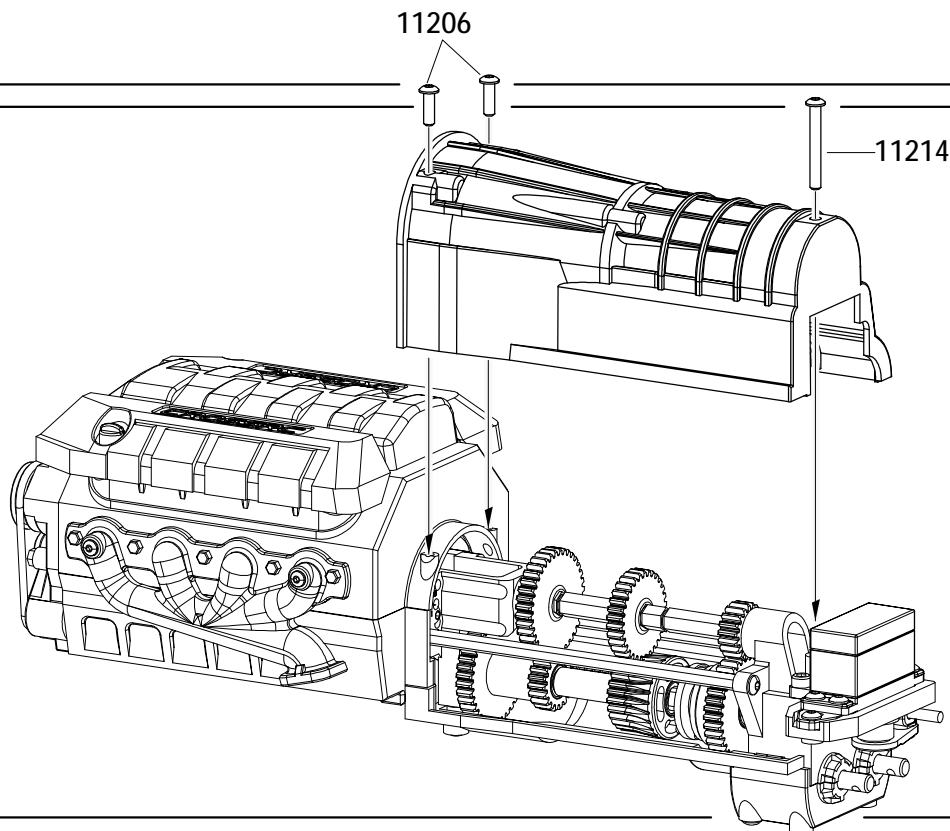

27 Rear Differential

11306 
M3x10 X4

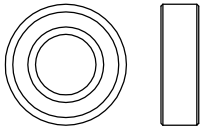
Ø8xØ16x5 X1
15009

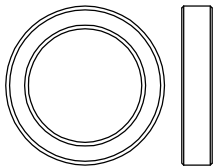

Ø15xØ21x4 X1
15011

GREASE
91007 X1

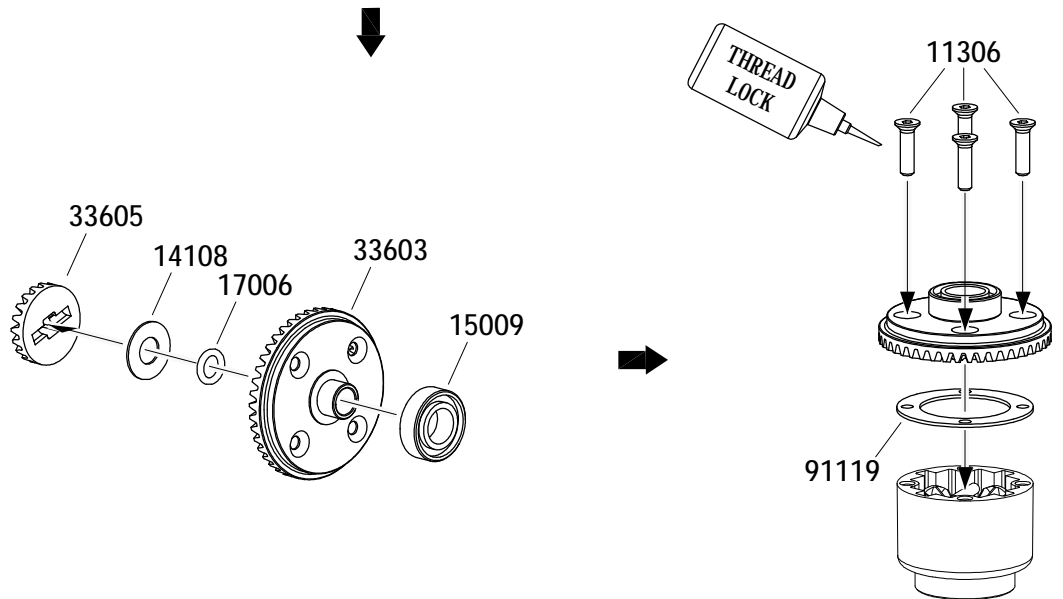
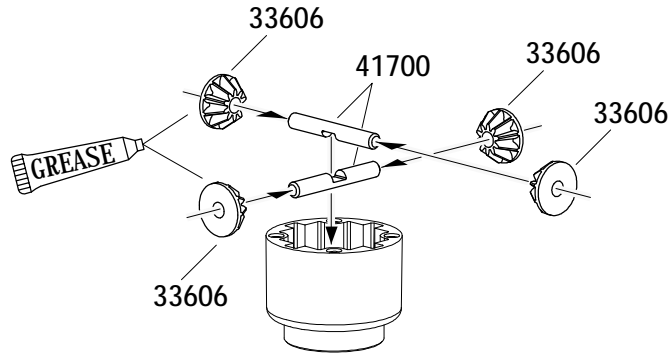
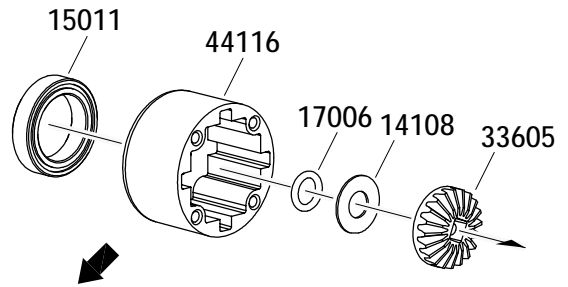

THREAD
LOCK

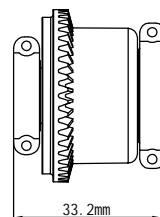
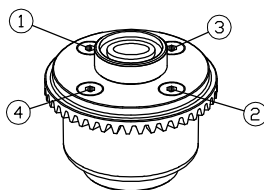



Repeat tightening in this order



28

11307  M3x14 X1

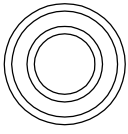
13006  $\varnothing 5 \times \varnothing 9.8 \times 0.5$ X1

 $\varnothing 8 \times \varnothing 16 \times 5$ X2
15009 

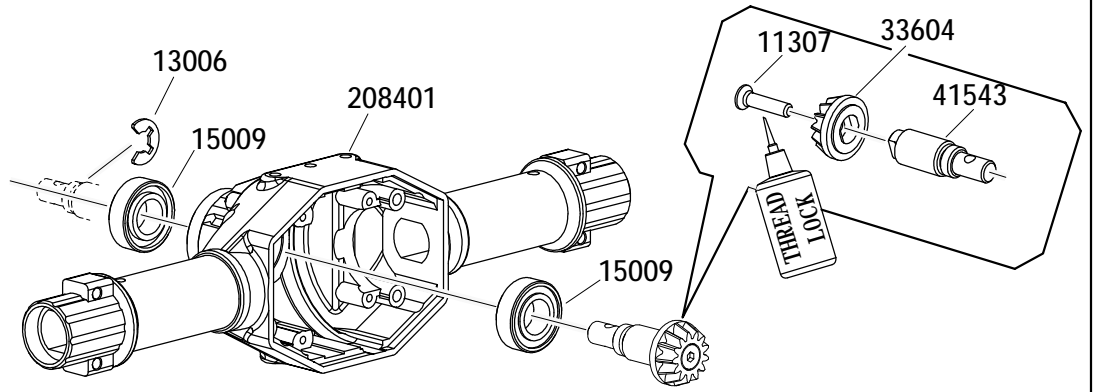

29



11106  M3x8 X2

11302  M3x6 X1

11303  M3x8 X1

11109  M3x14 X1

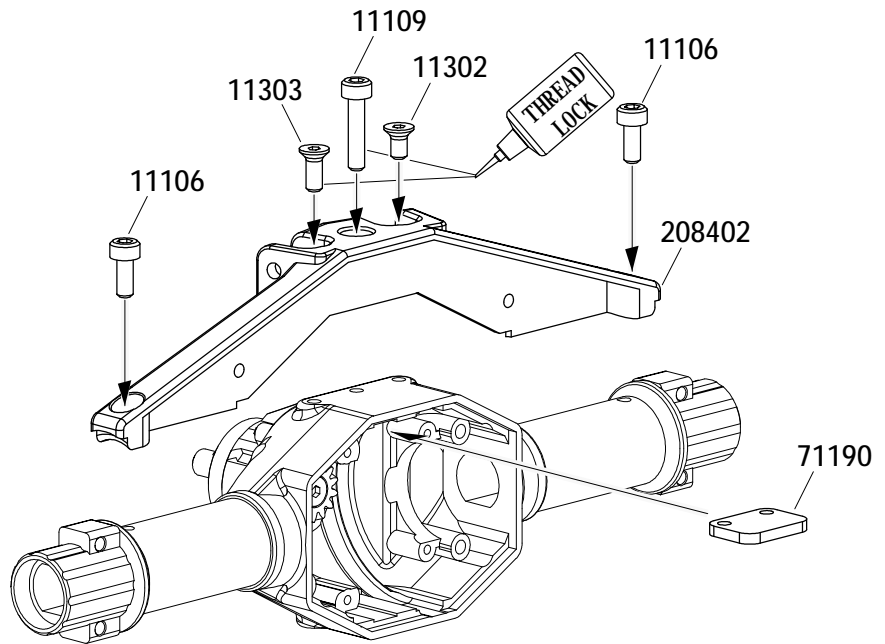

30

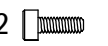
11102  M2x6 X4

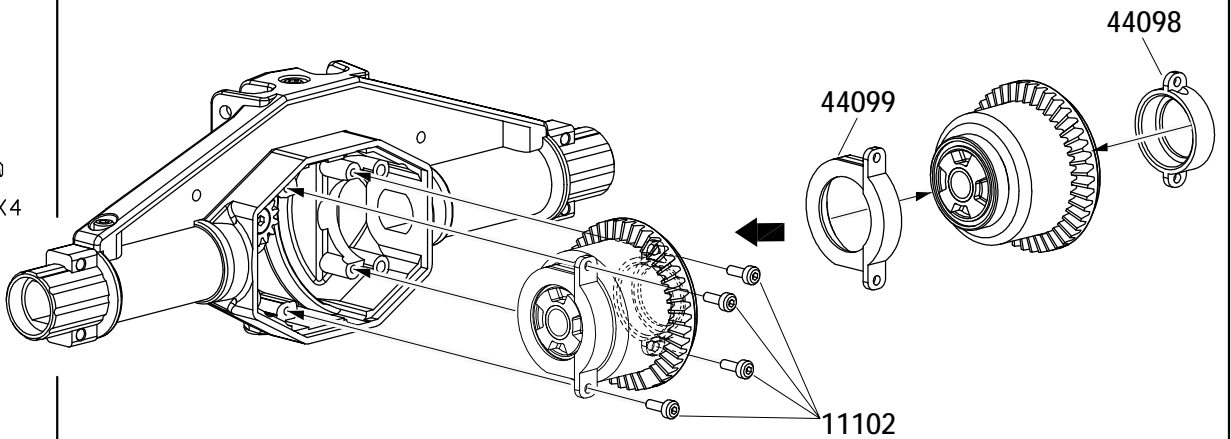

31

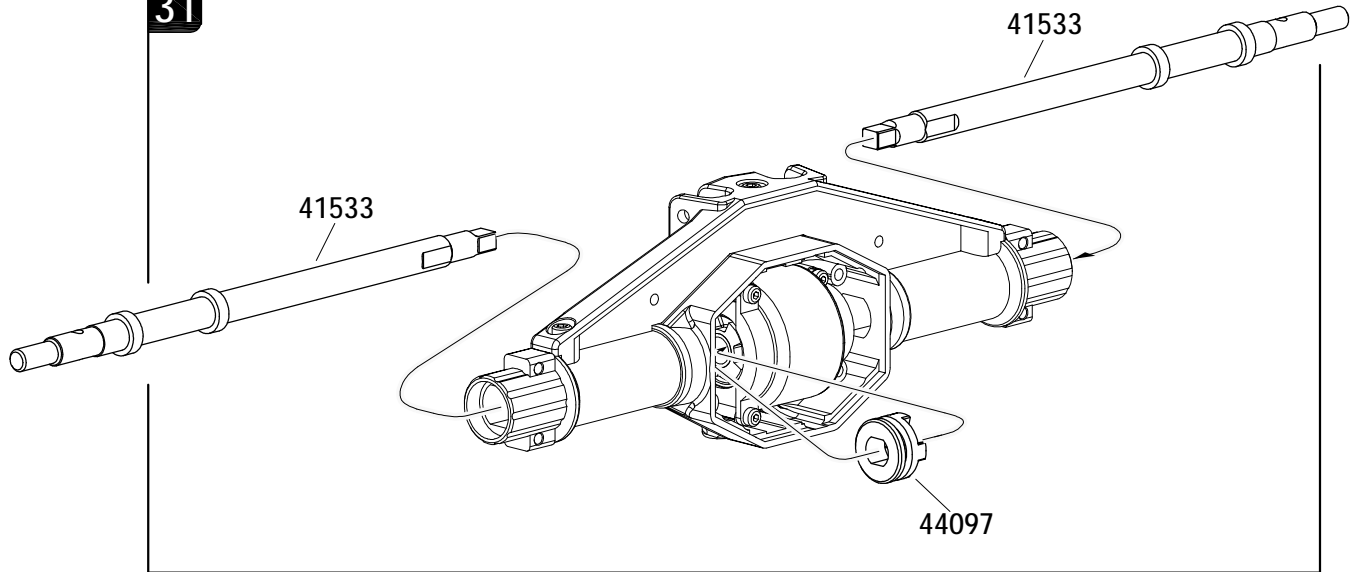

32

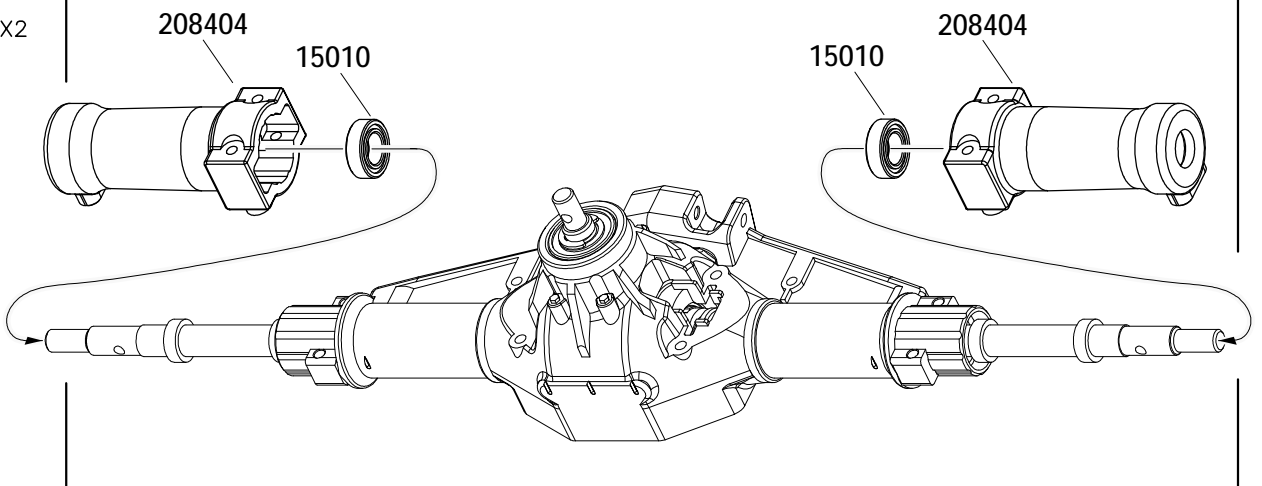
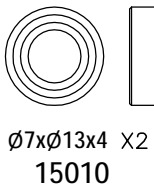

33

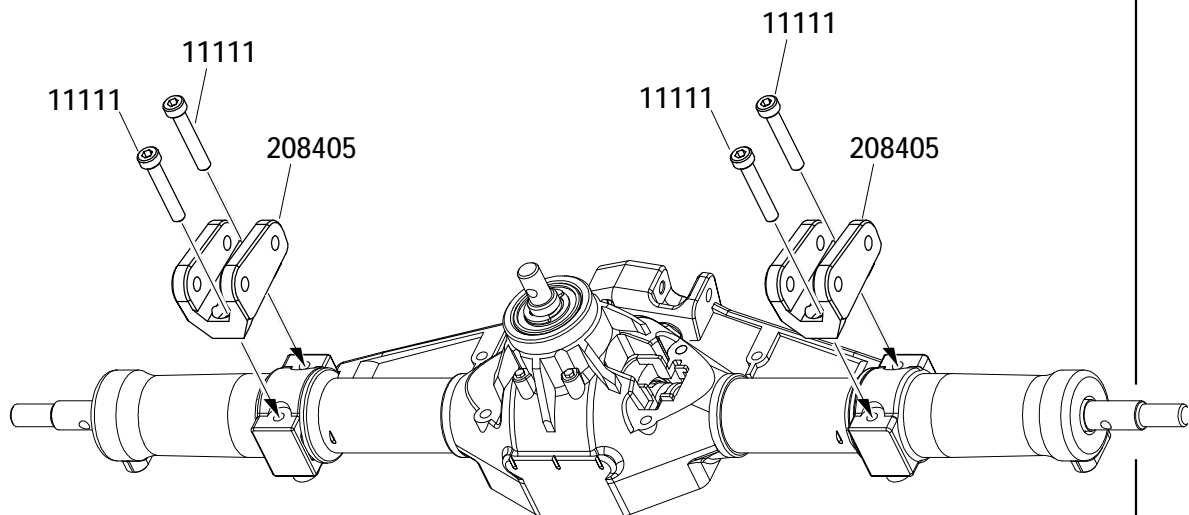
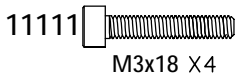

34

11401 
M3x4 X1

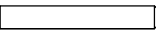
41703 
M3x21 X1

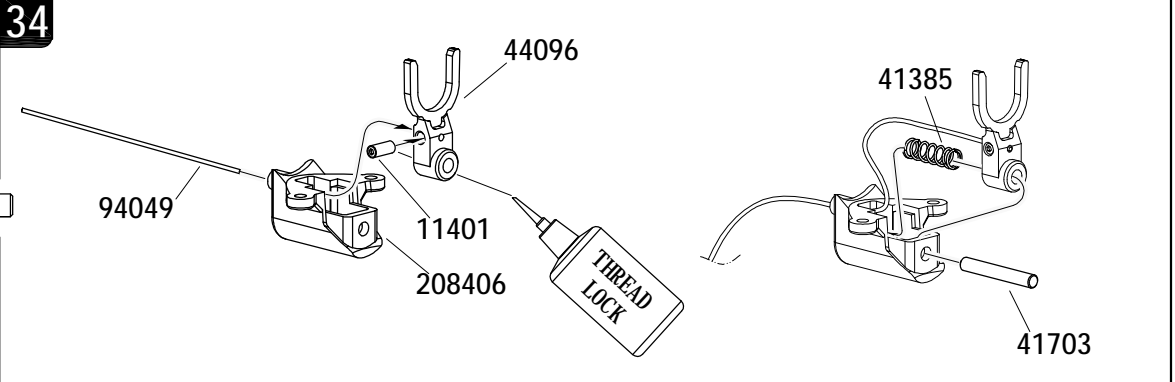

35

11120 
M2.5x20 X4

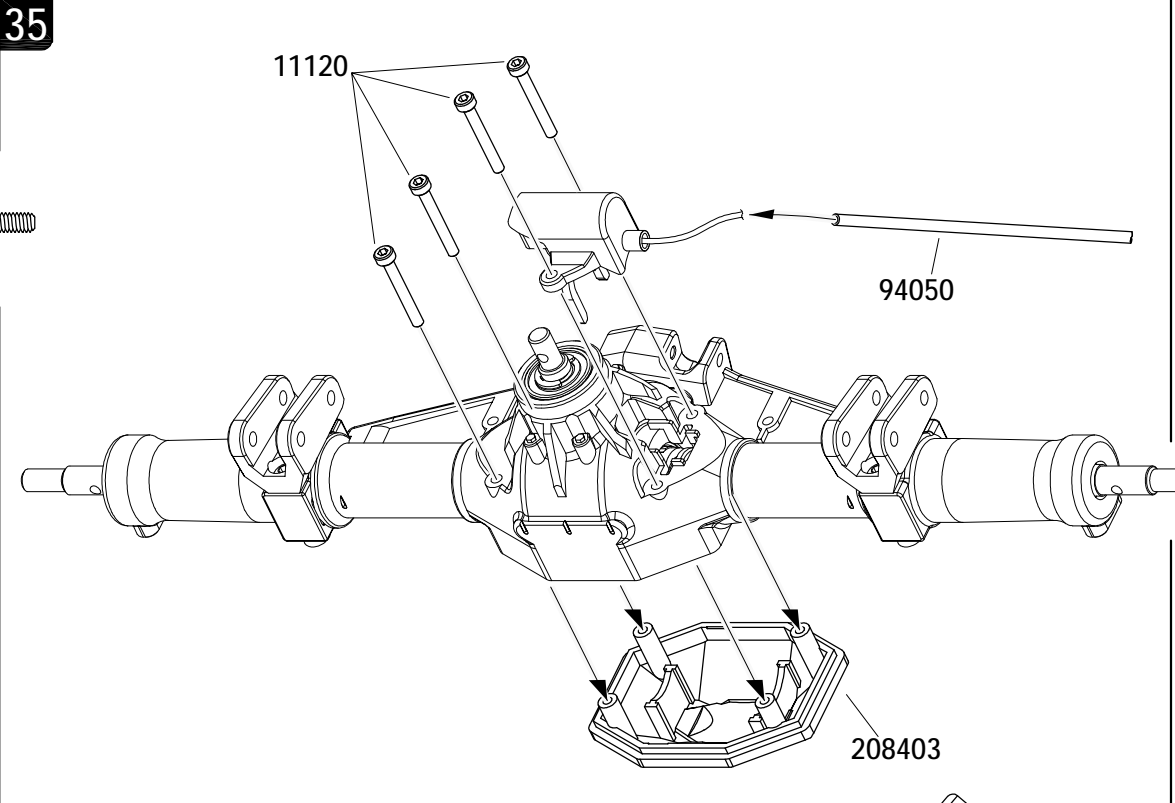

36

41702 
M2.5x12.8 X2

11405 
M4x4 X2

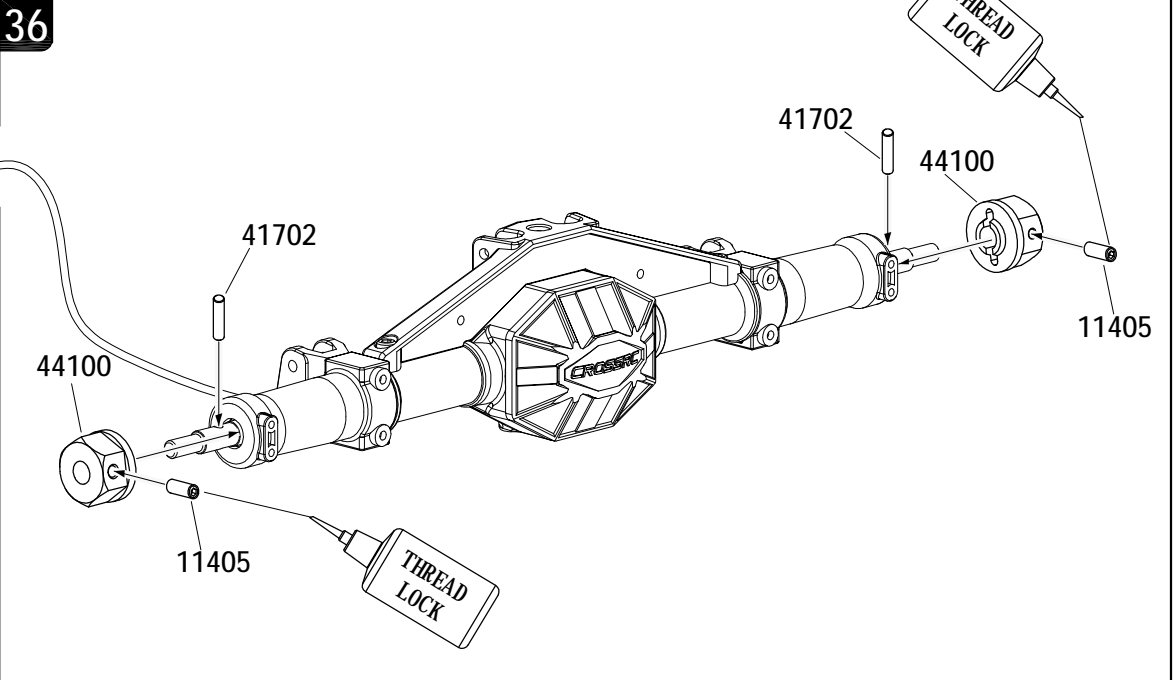

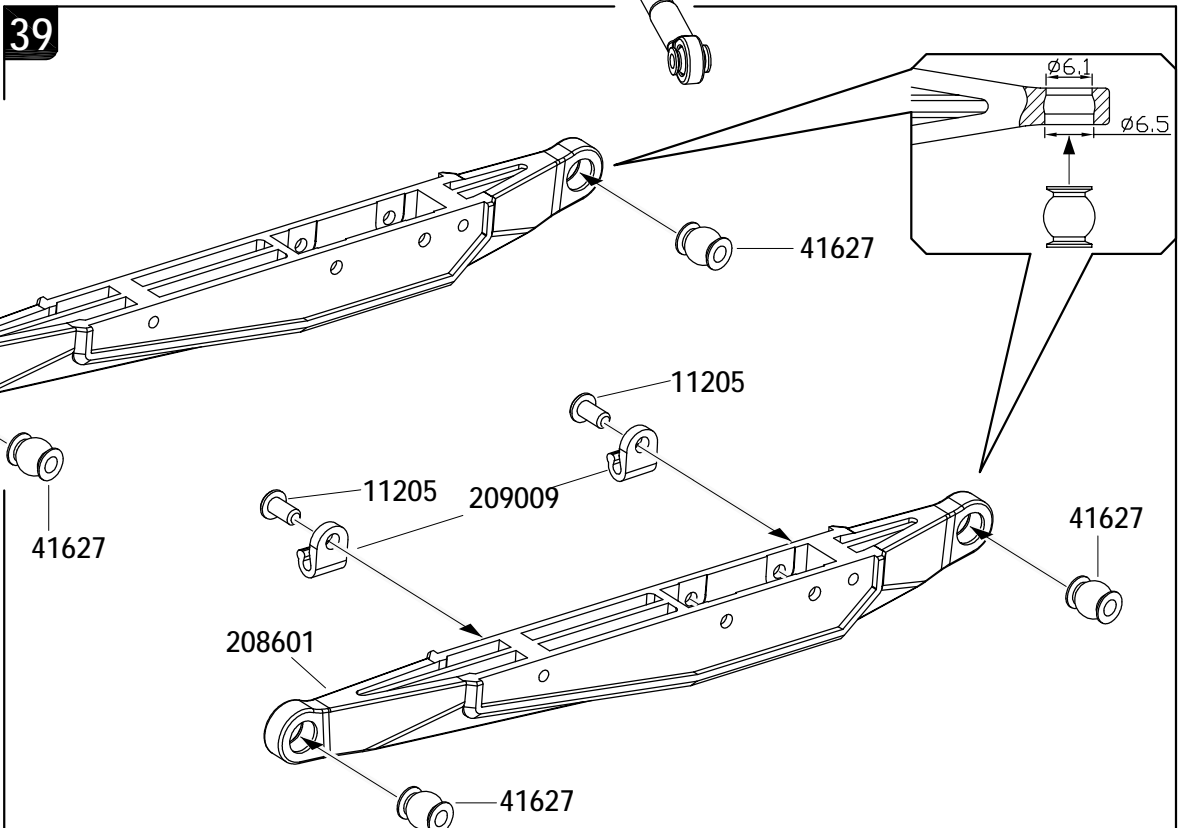
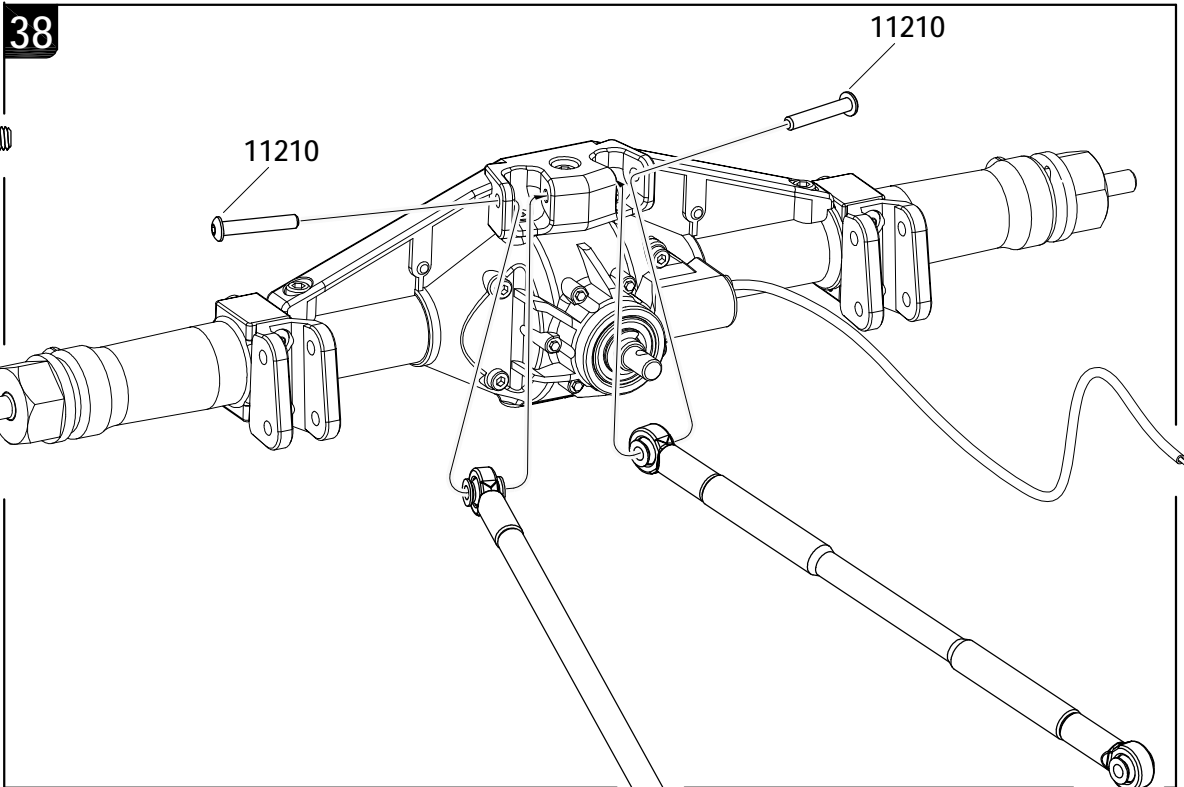
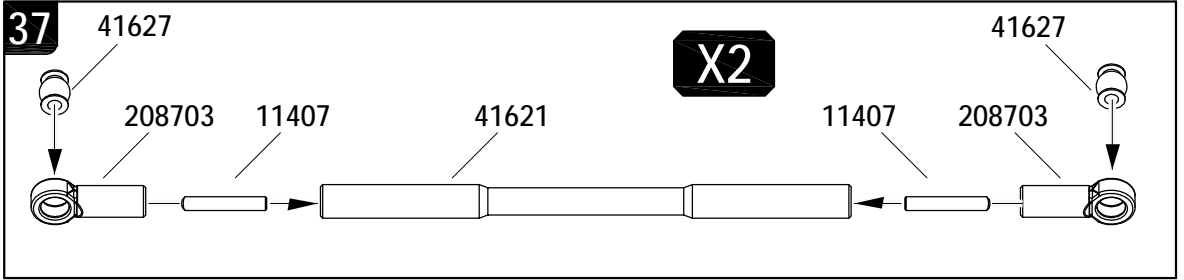



40

11112 
M3x20 X2

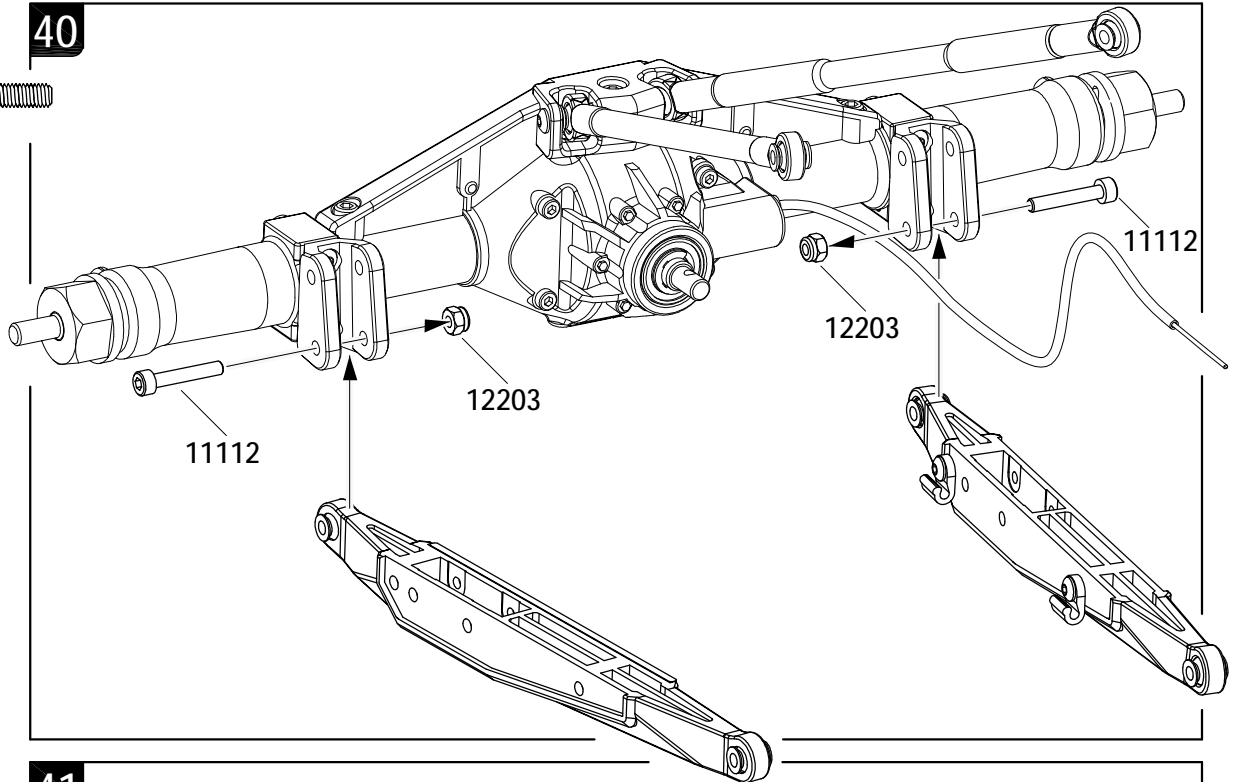
12203 
M3 X2



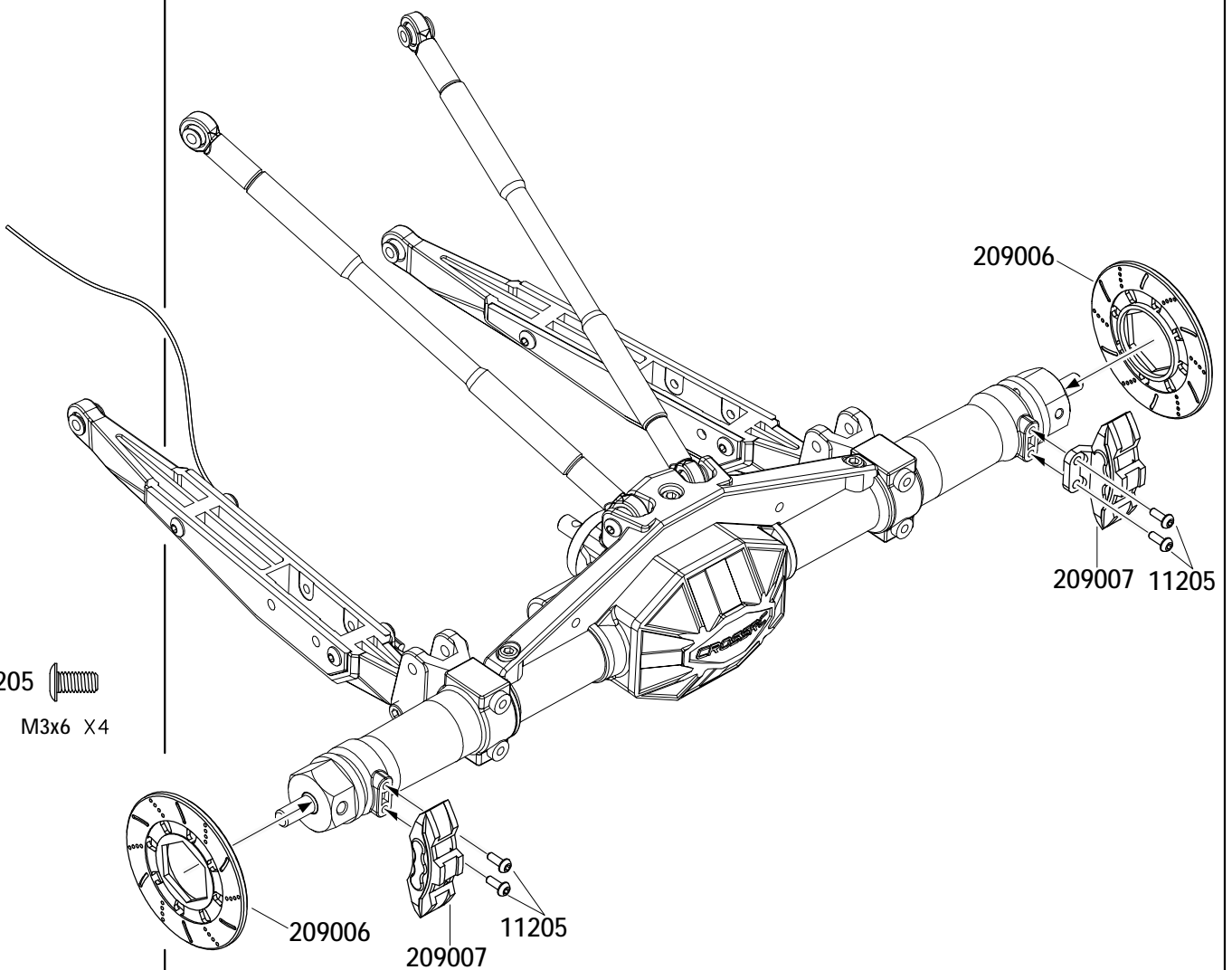

41

11205 
M3x6 X4





42

13003 
 Ø2.5xØ6x0.4 X8

50021 
 Ø7.5xØ3.5xØ2 X12

17001 
 Ø8xØ6xØ1 X4

11102 
 M2x6 X4

14109 
 Ø2xØ4x0.5 X4

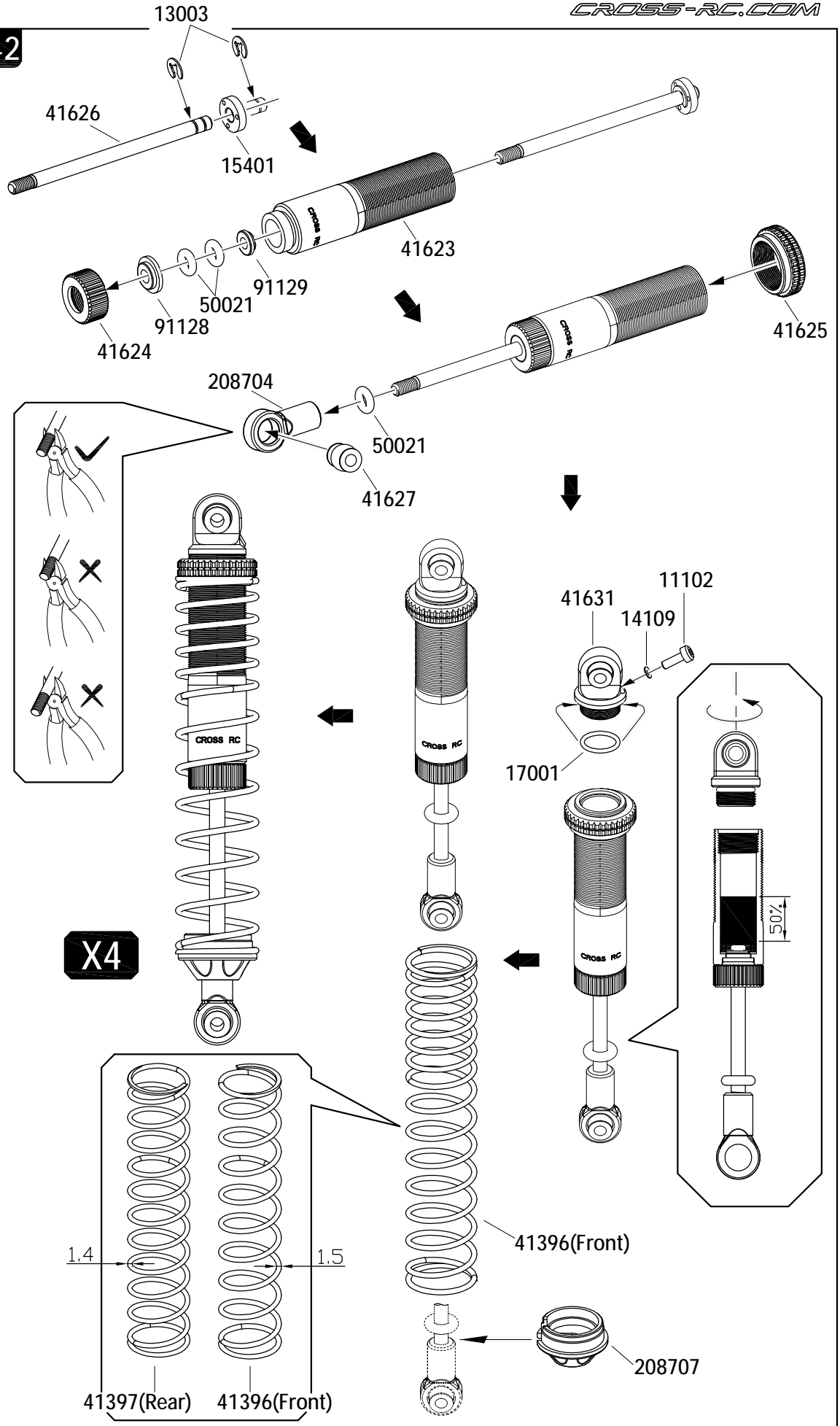

41627 
 Ø6.8x8 X4

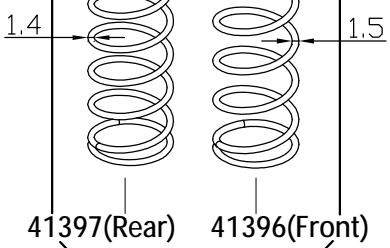

X4



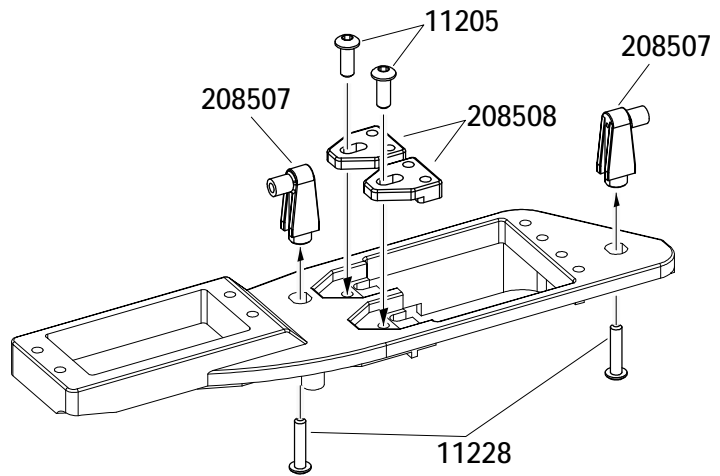

43

- 11205  M3x6 X2
- 11228  M2.5x12 X2



44

- 11205  M3x6 X4
- 11107  M3x10 X1
- 12206  M2 X2

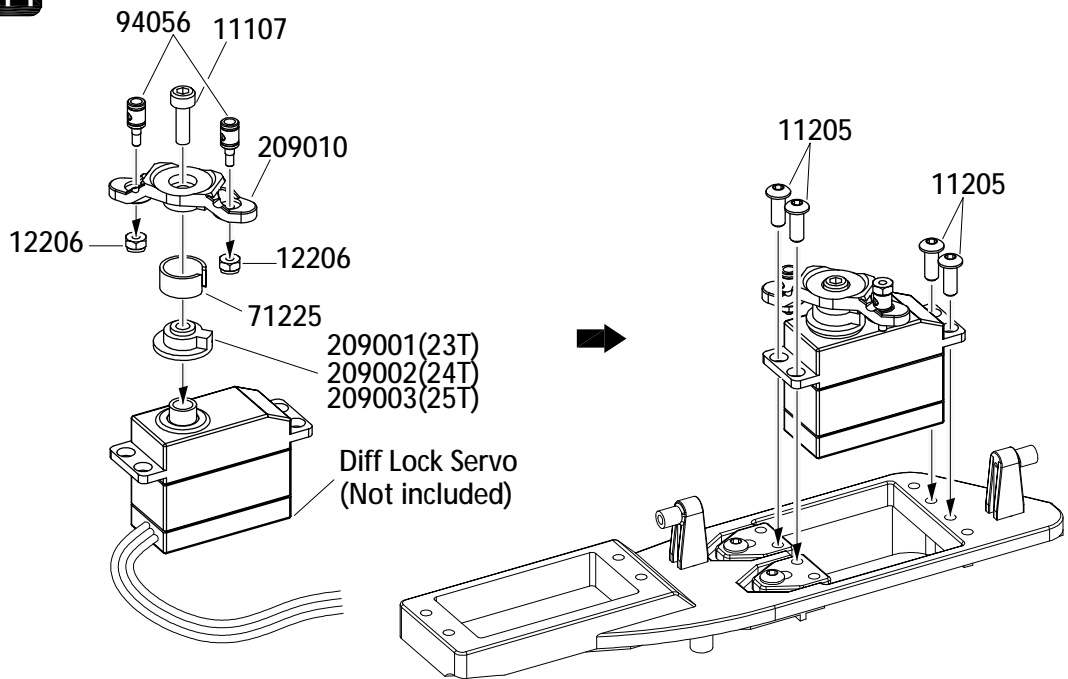

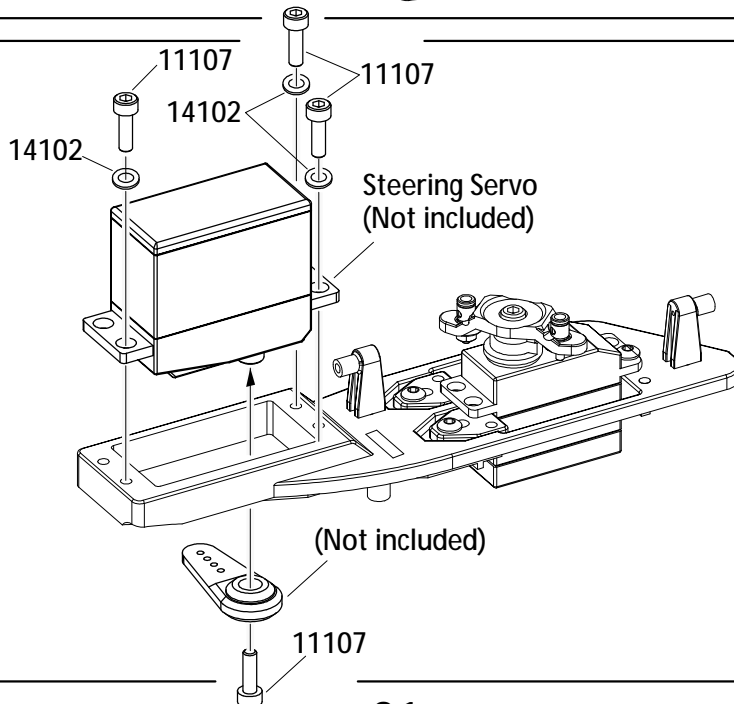

45

- 11107  M3x10 X4



46

11205 
M3x6 X2

11206 
M3x8 X2

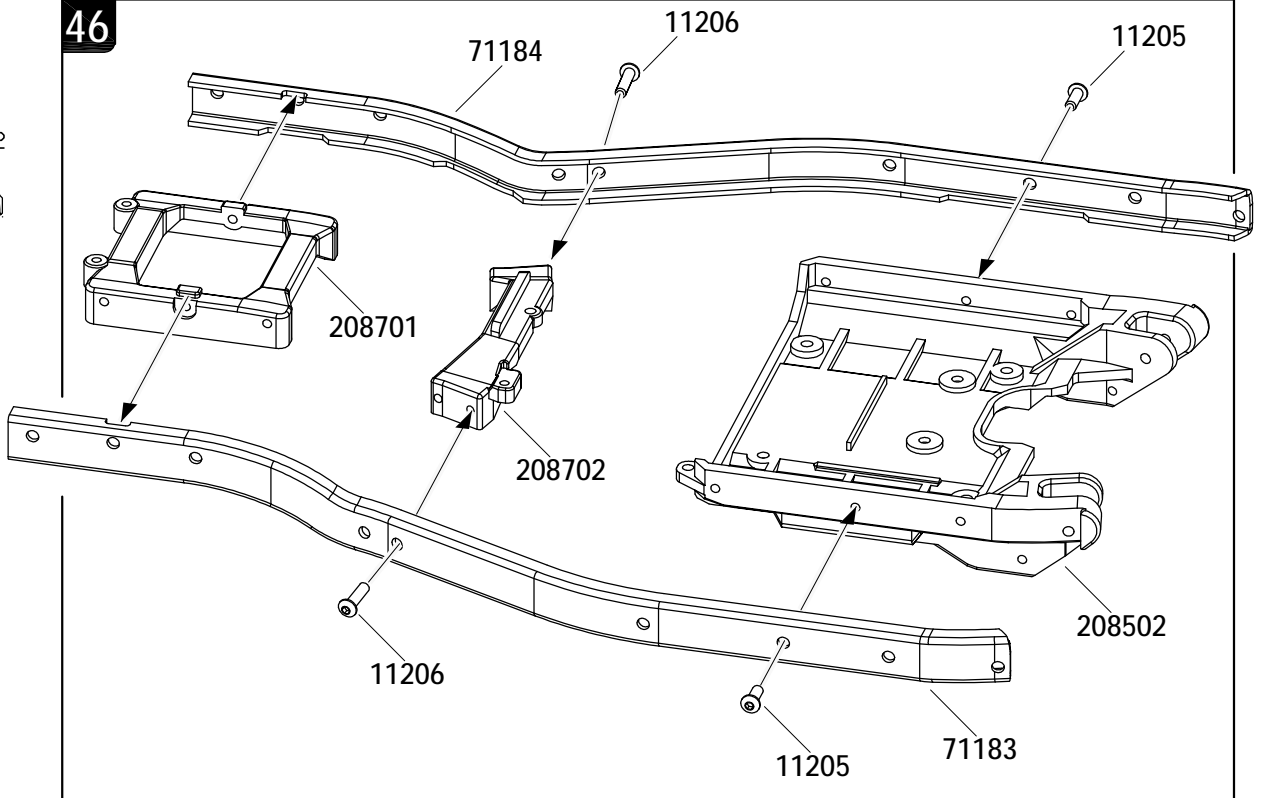

47

11206 
M3x8 X2

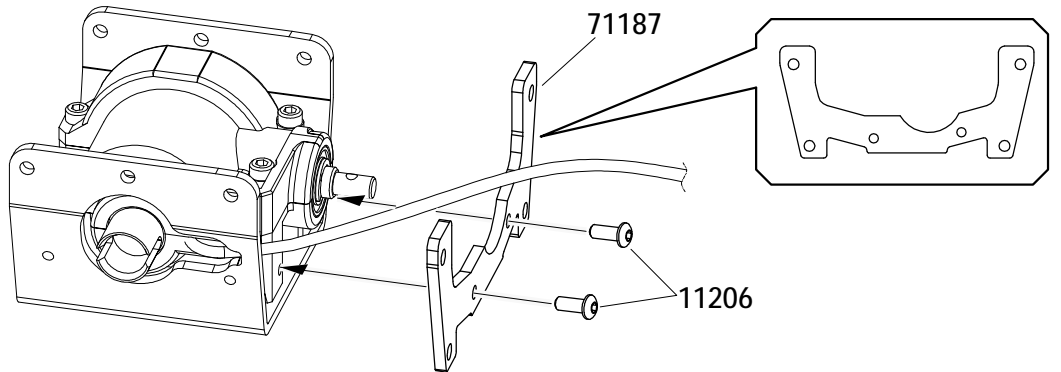

48

11306 
M3x10 X2

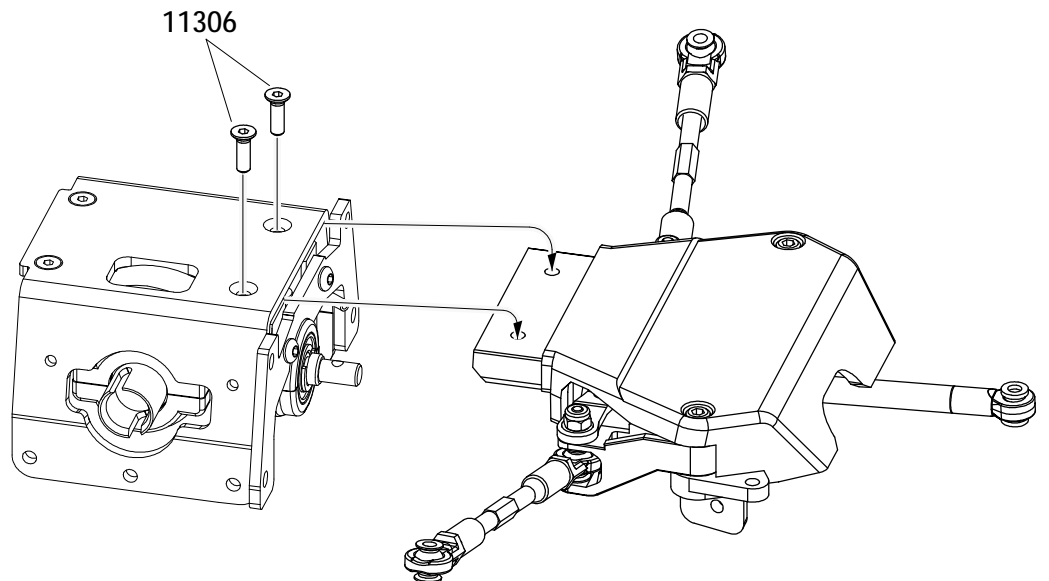

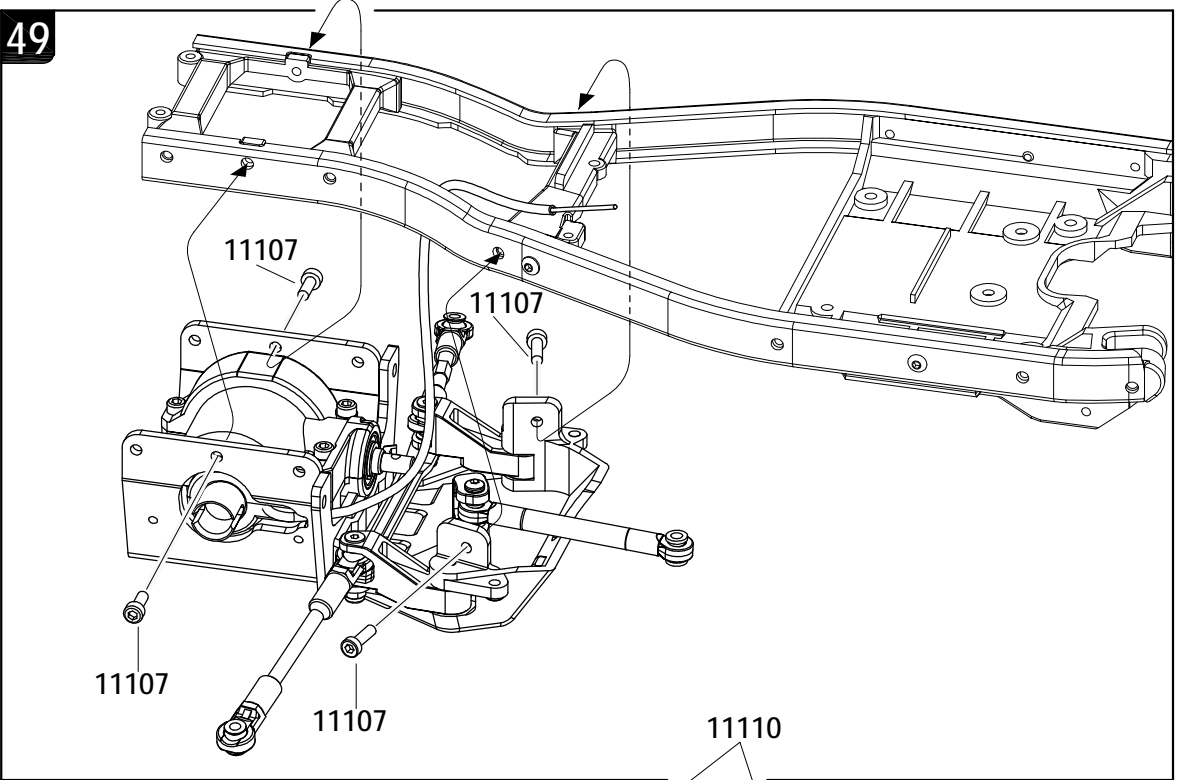

49

11107 
M3x10 X4



50



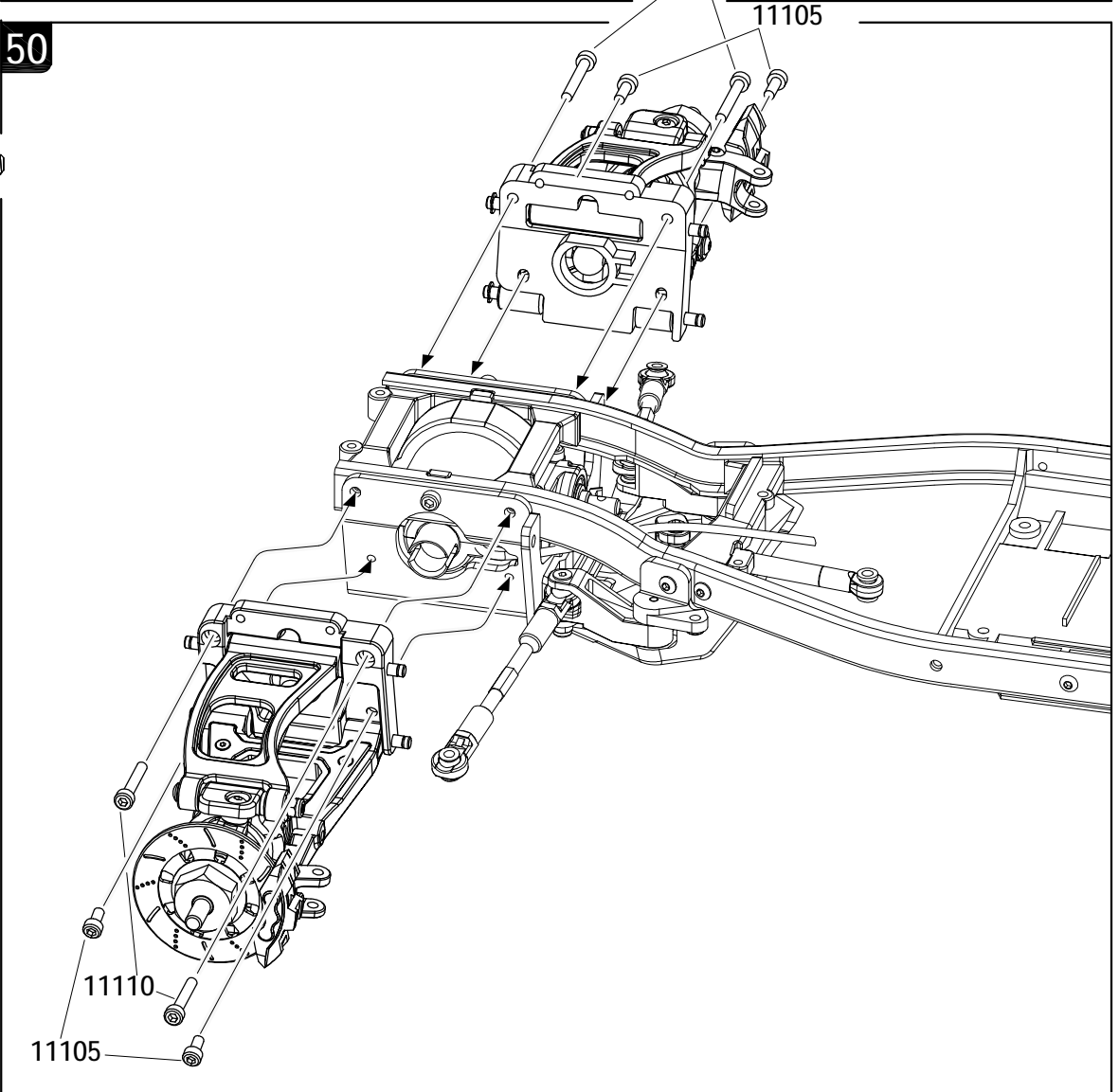

11110 
M3x16 X4

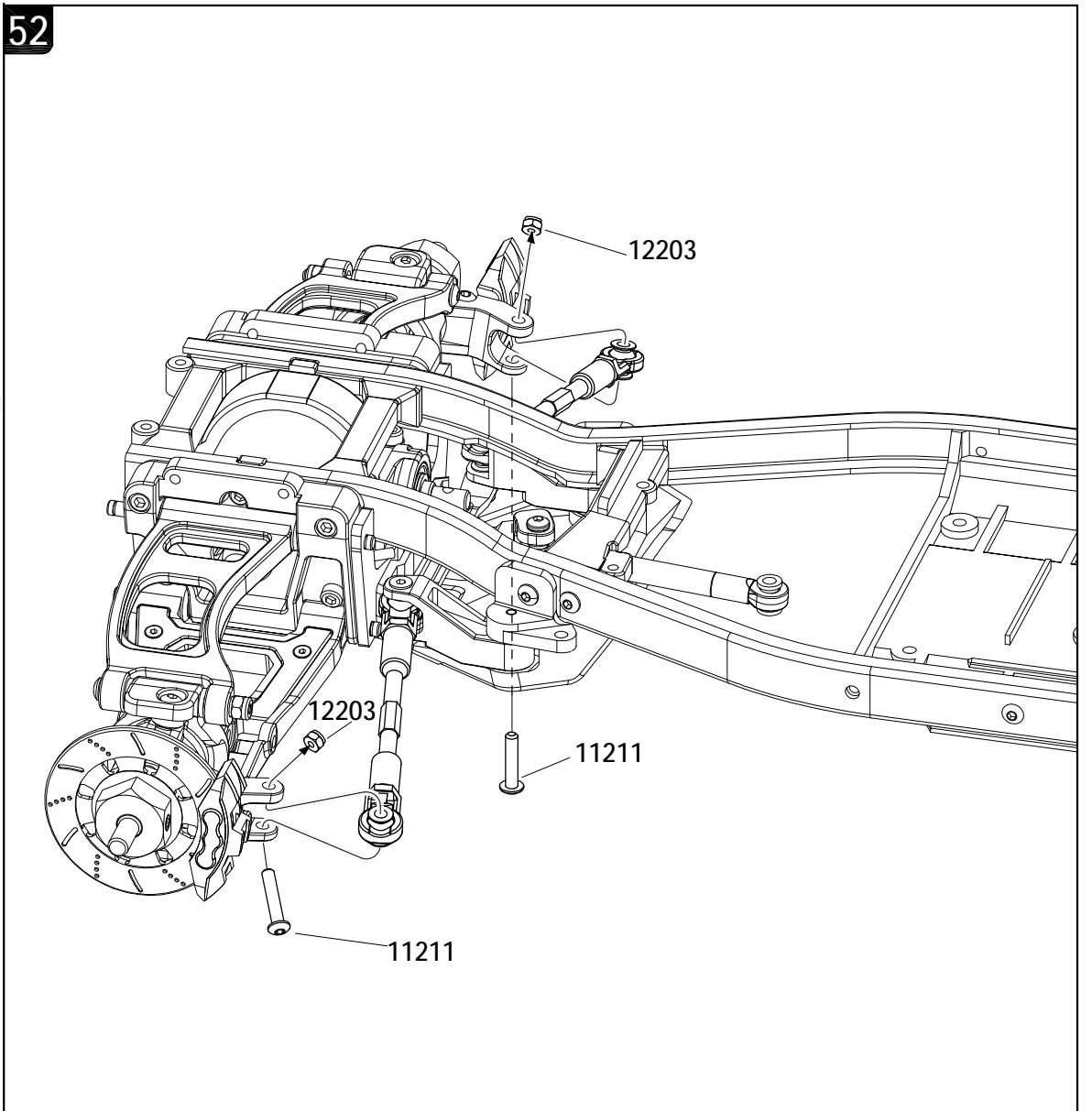
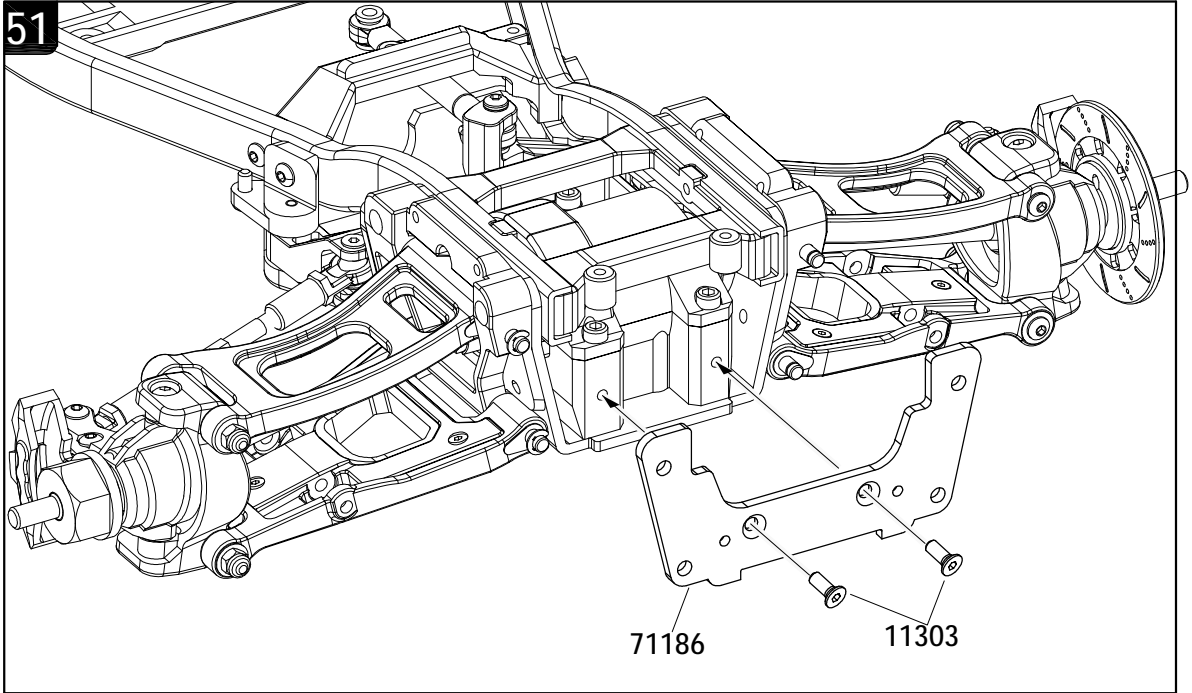
11105 
M3x6 X4





53

- 11306  M3x10 X2
- 11106  M3x8 X1
- 11110  M3x16 X2
- 12203  M3 X1
- 41629  Ø1.5xØ1x20 X2

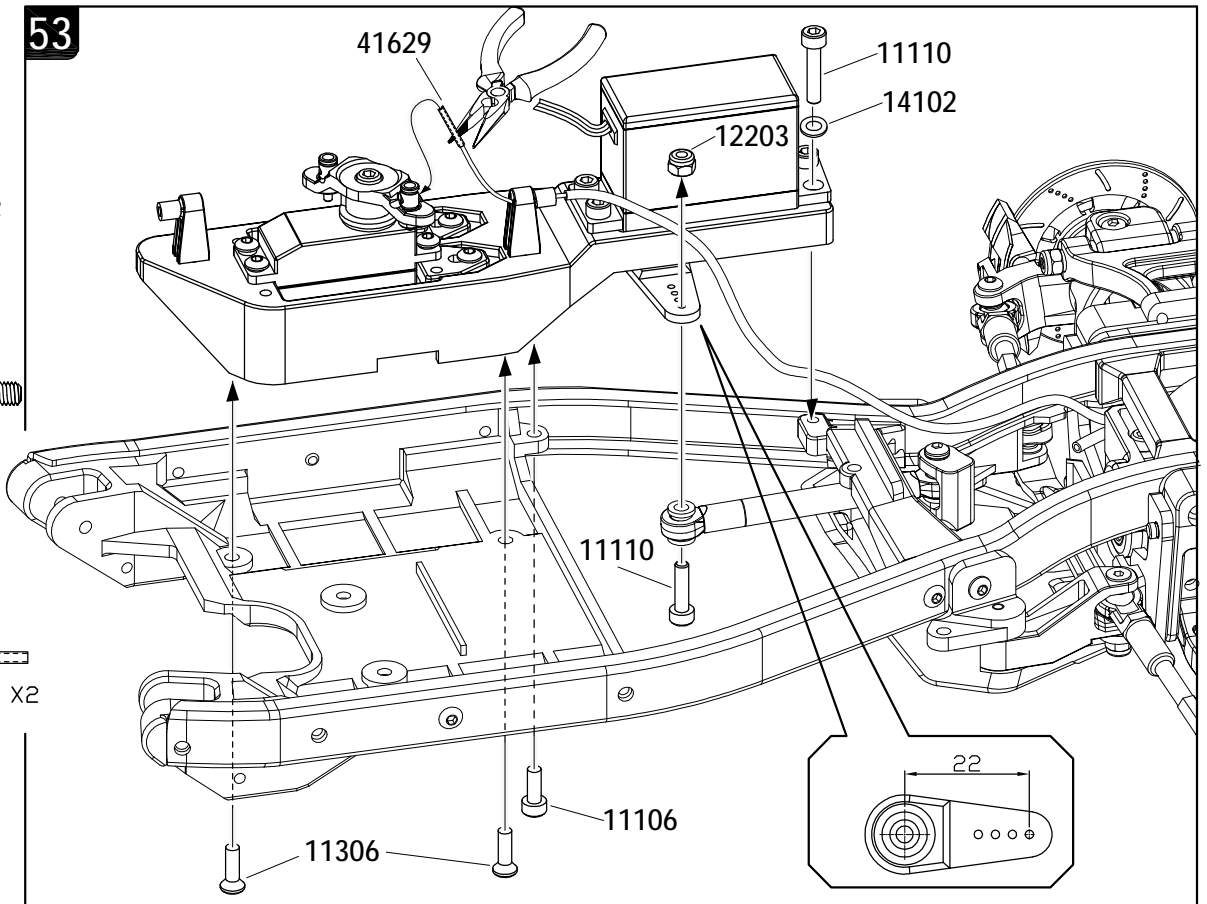

54

- 11306  M3x10 X2

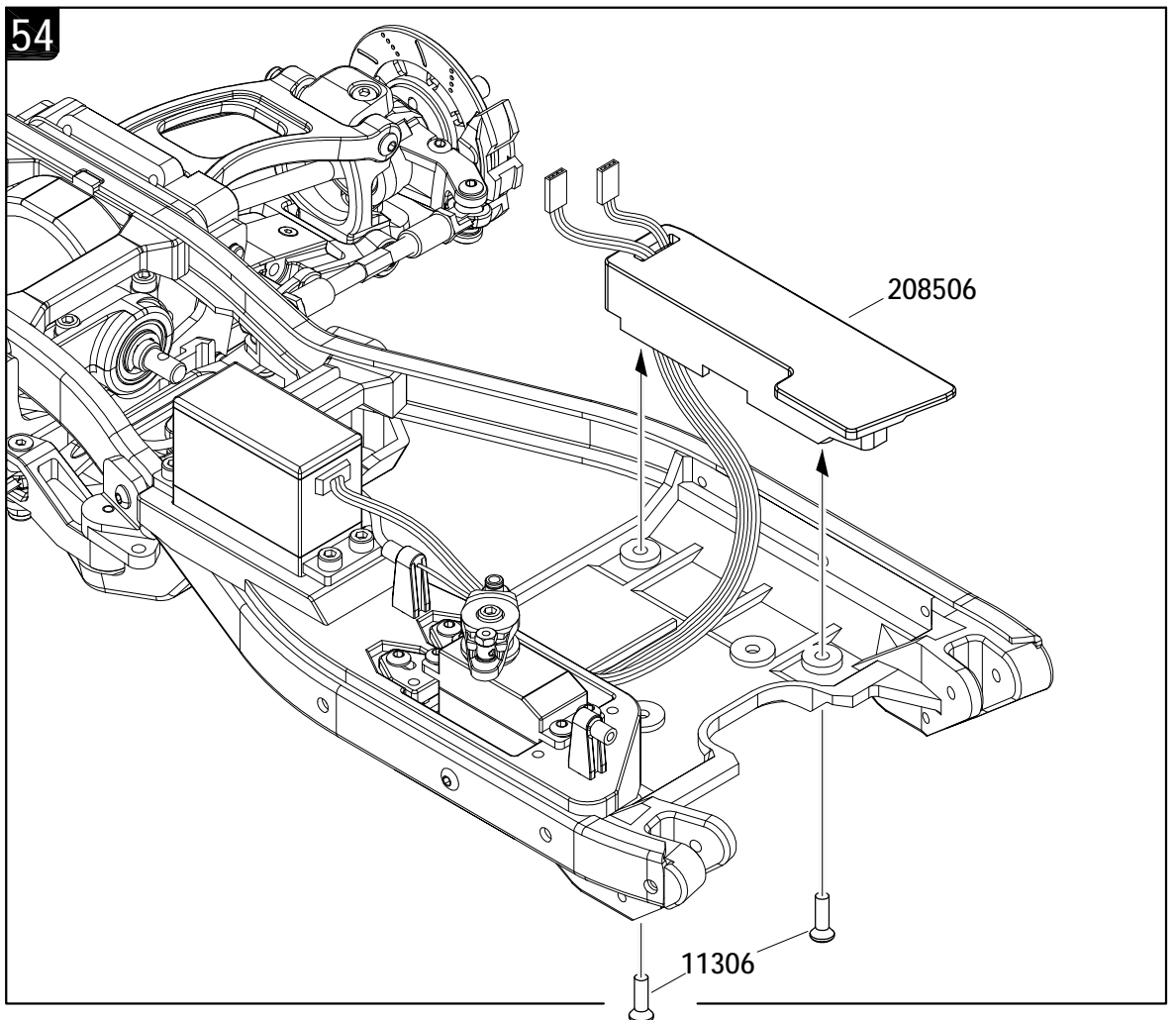

55

11107 M3x10 X3

11112 M3x20 X2

M4x11 X2
11409

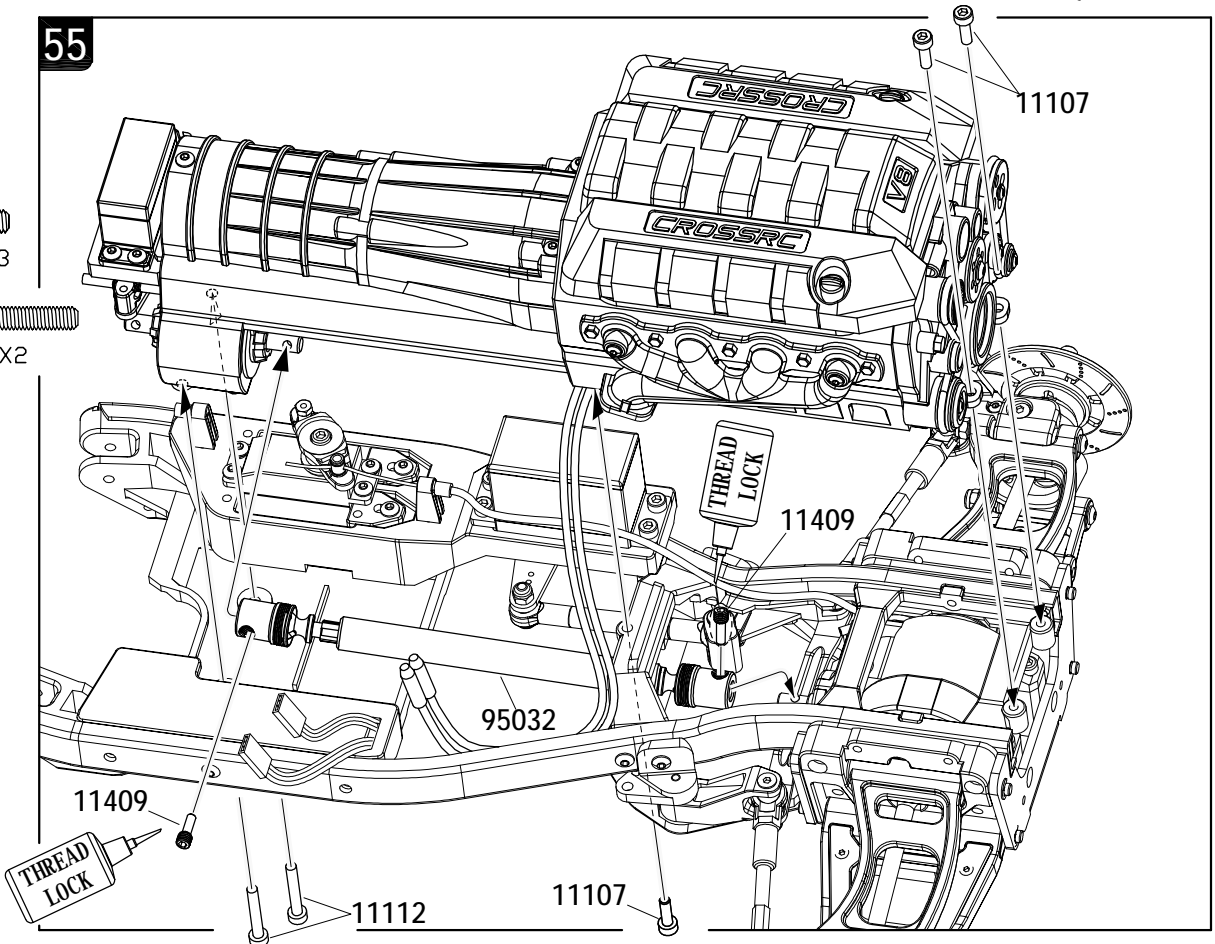

56

11107 M3x10 X2

ABS
CEMENT

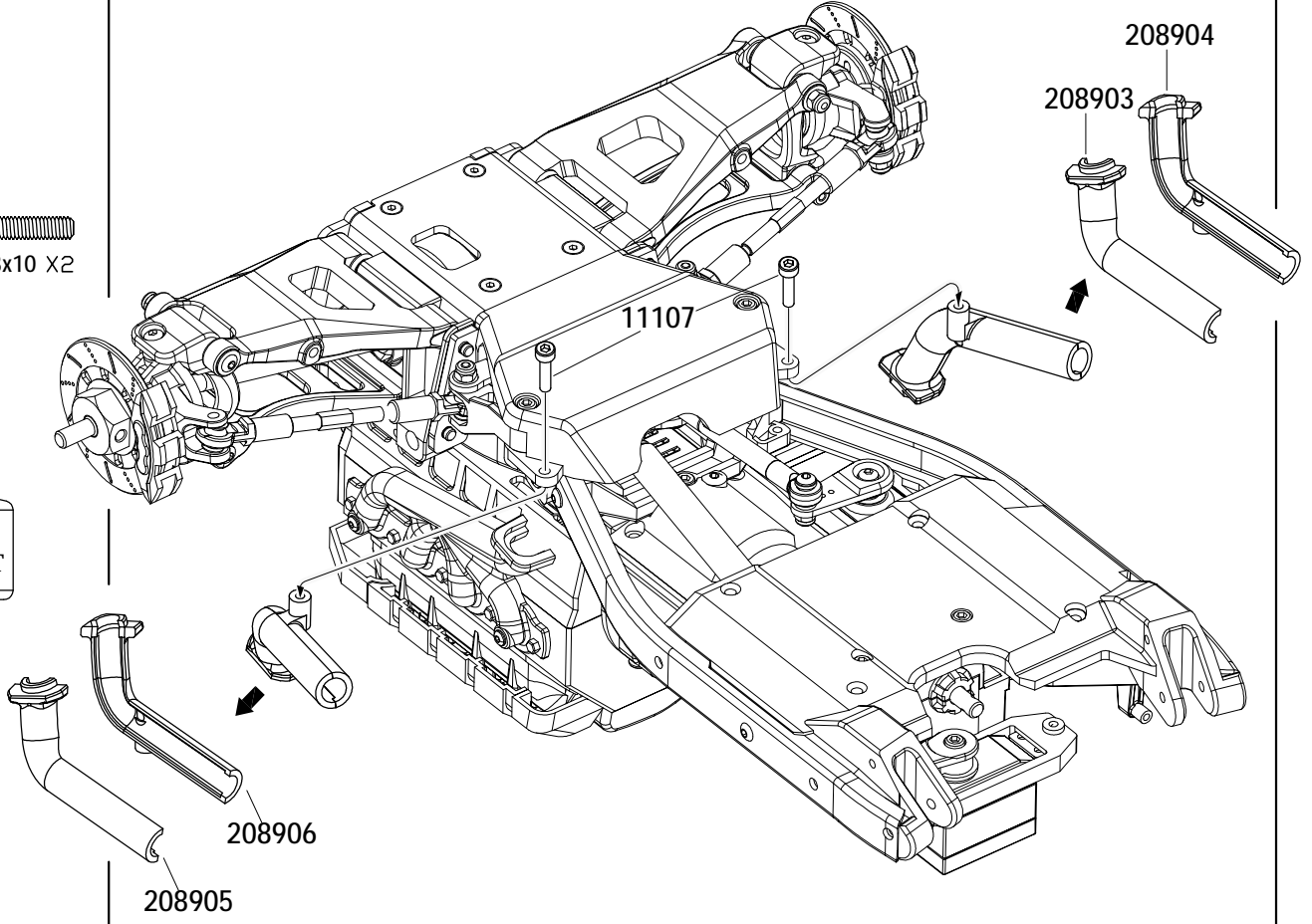

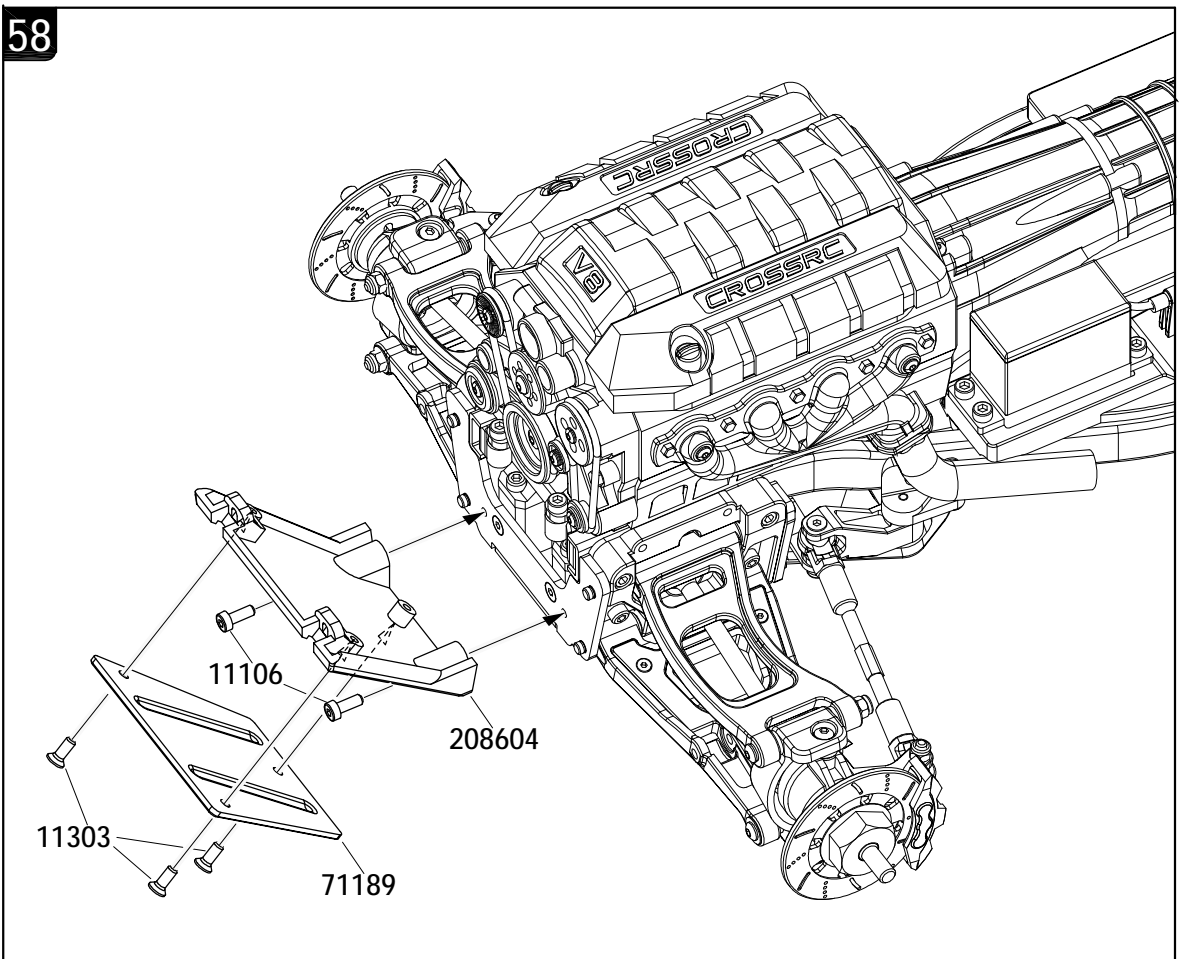
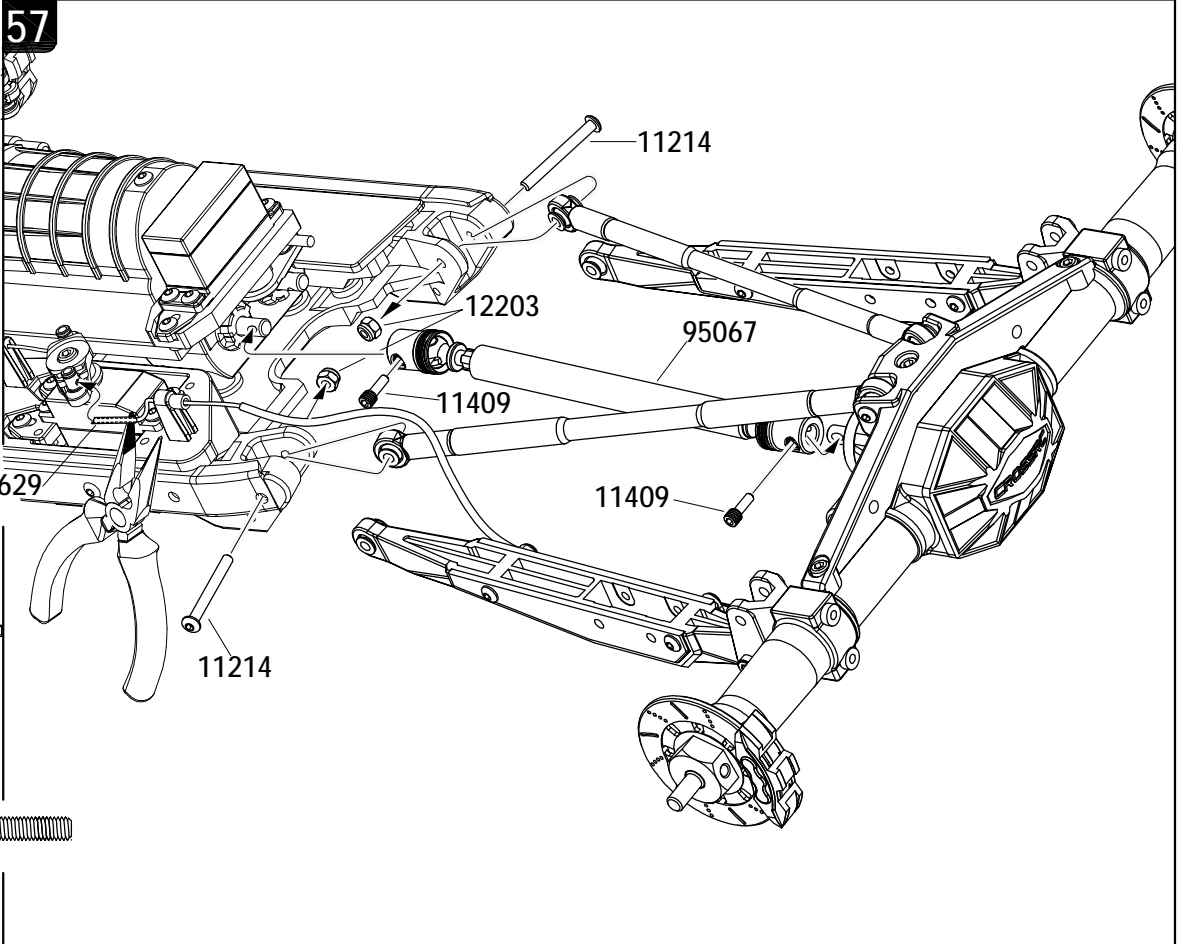

59

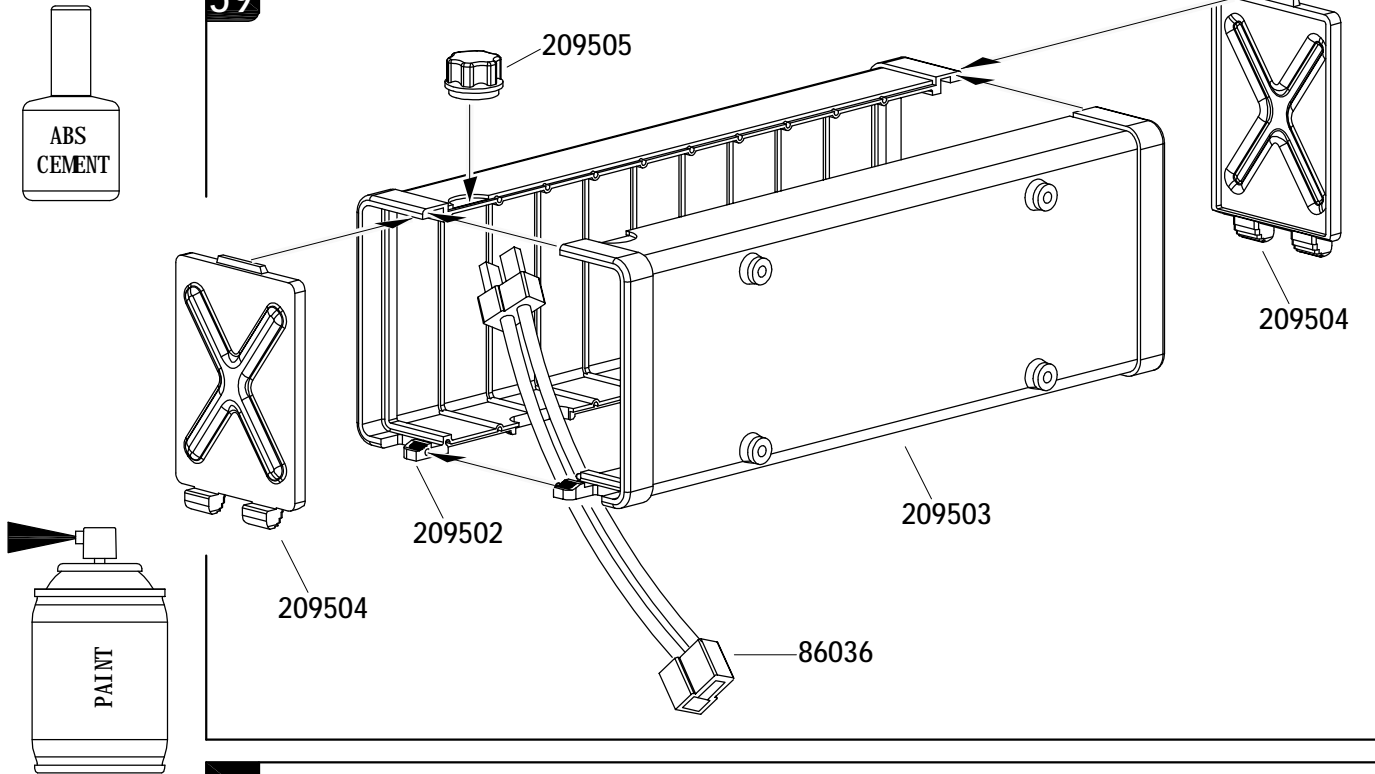

60

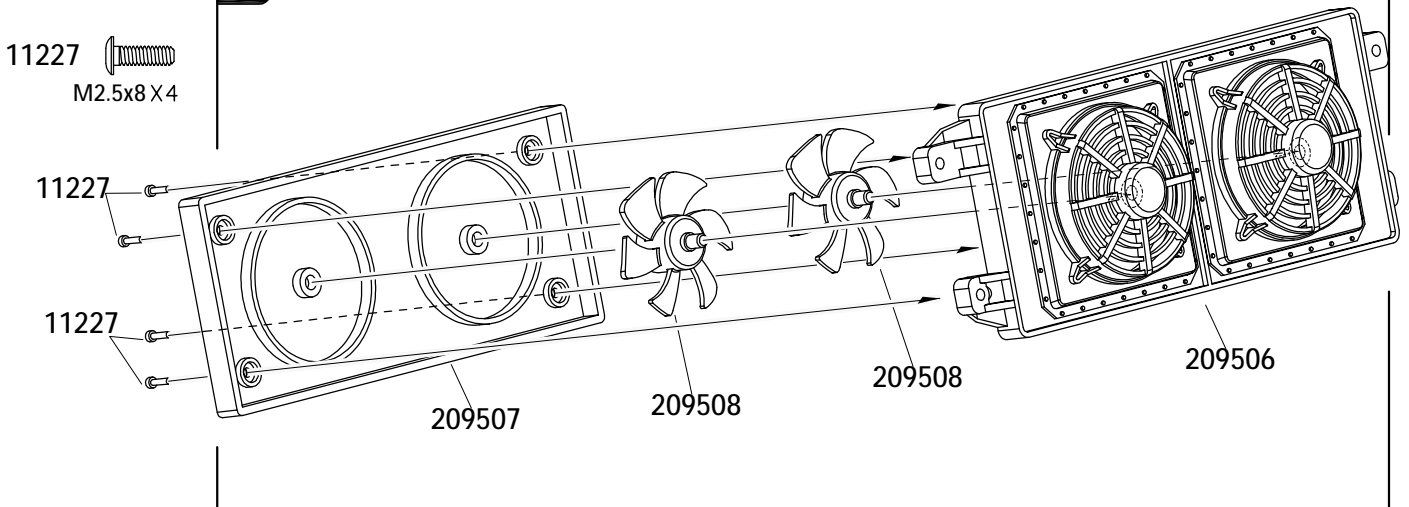

61

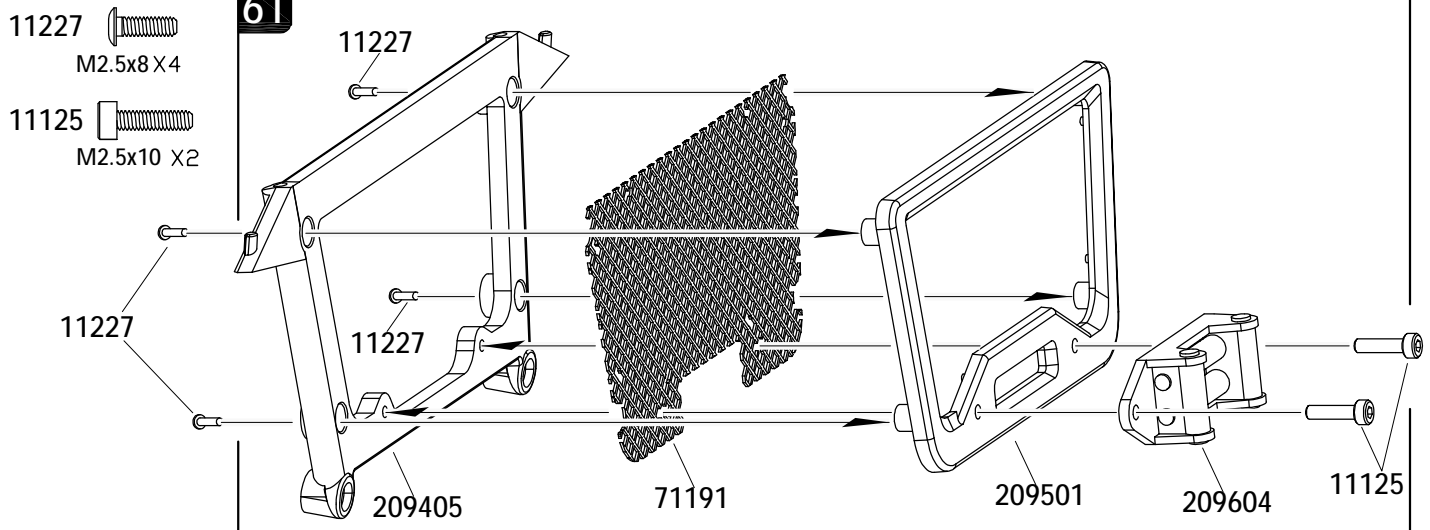

62

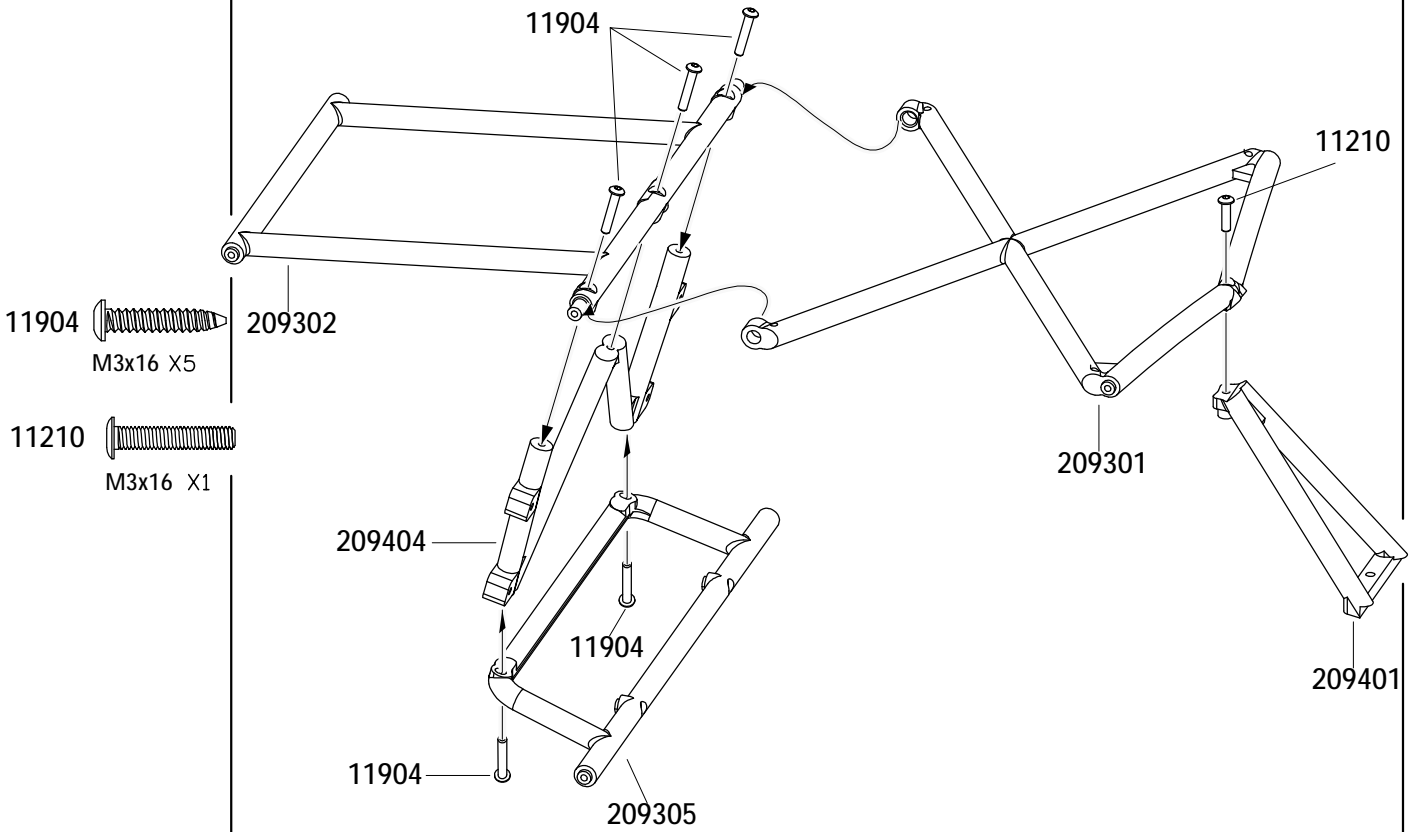

63

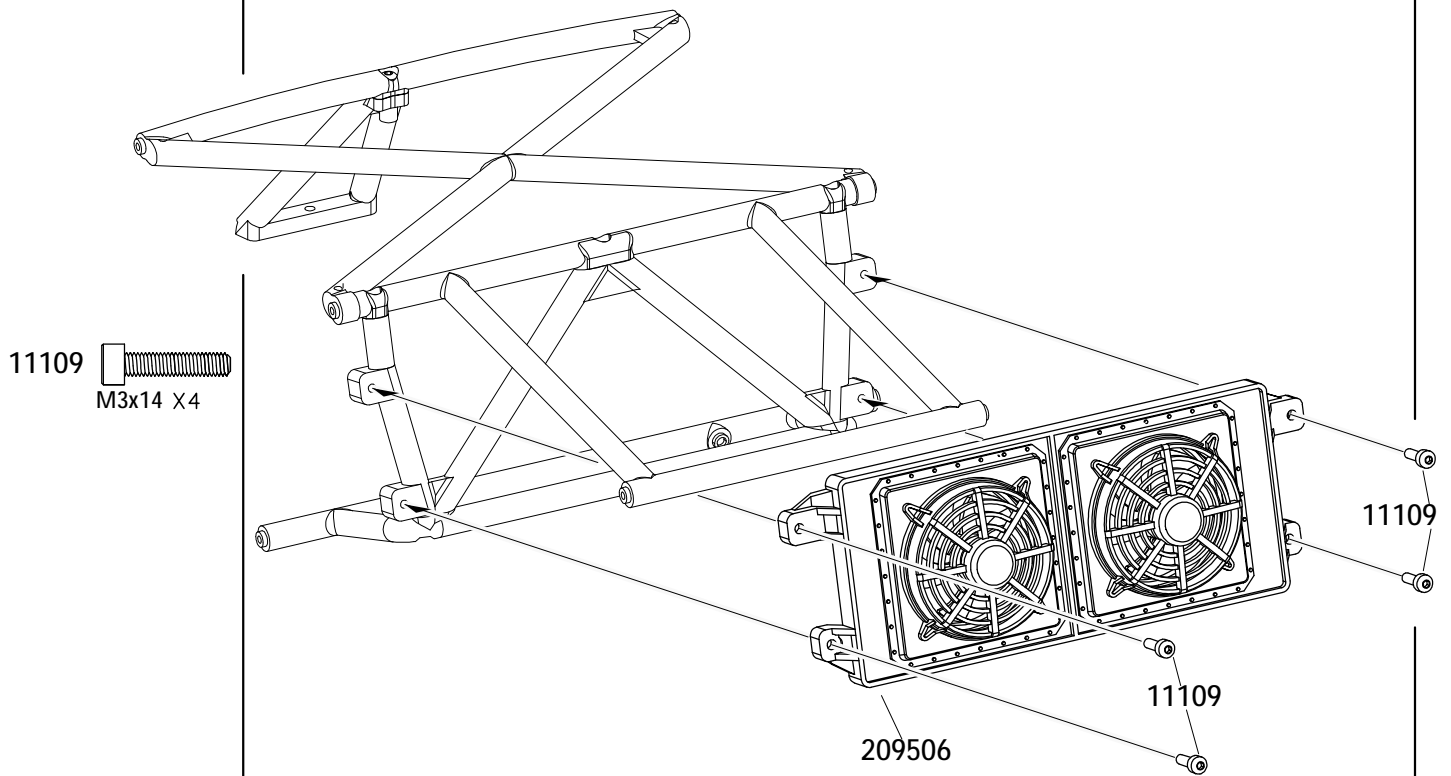

64

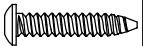
11904 
M3x16 X7

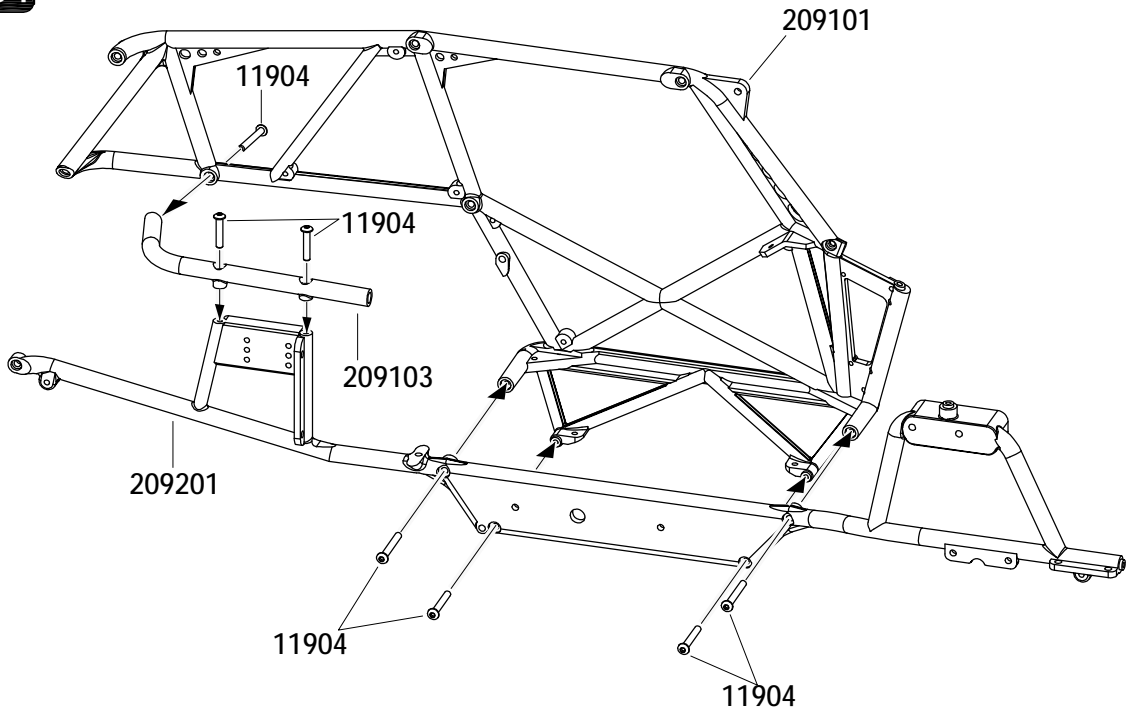

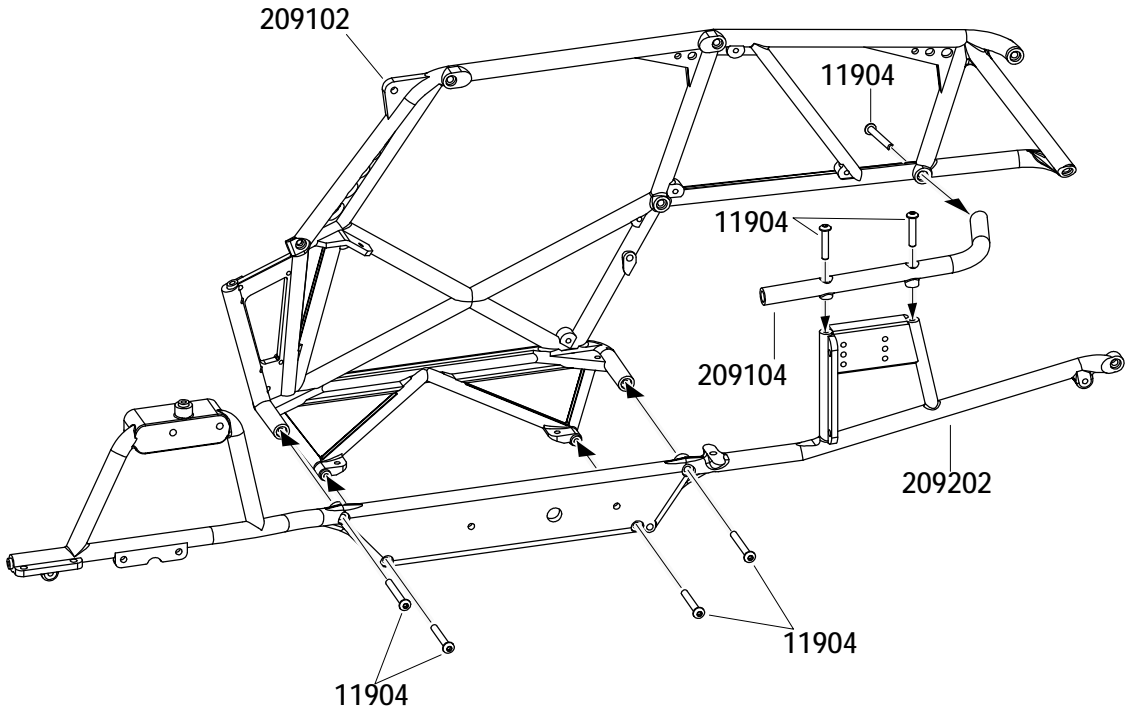

65

11904 
M3x16 X7



66

11904 
M3x16 X3

11905 
M3x20 X1

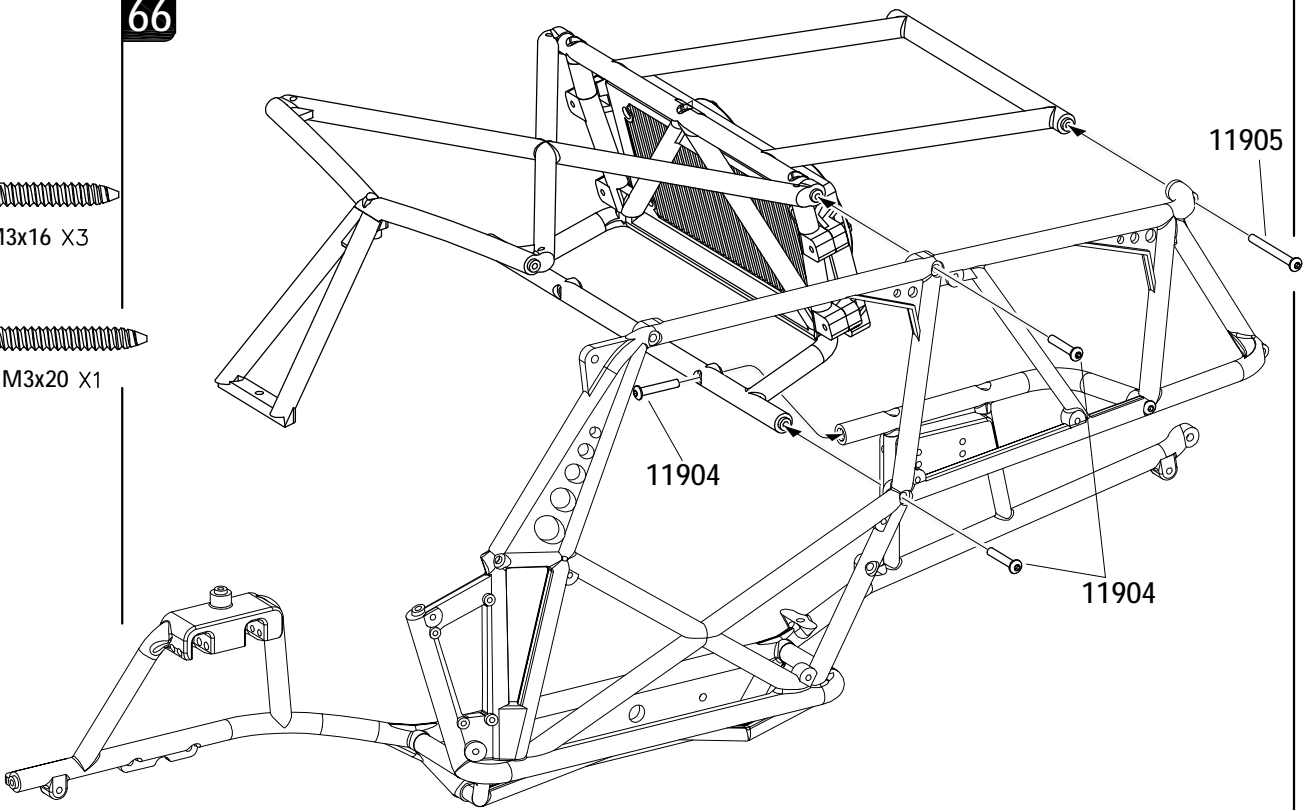

67

11904 
M3x16 X2

11905 
M3x20 X2

11206 
M3x8 X2

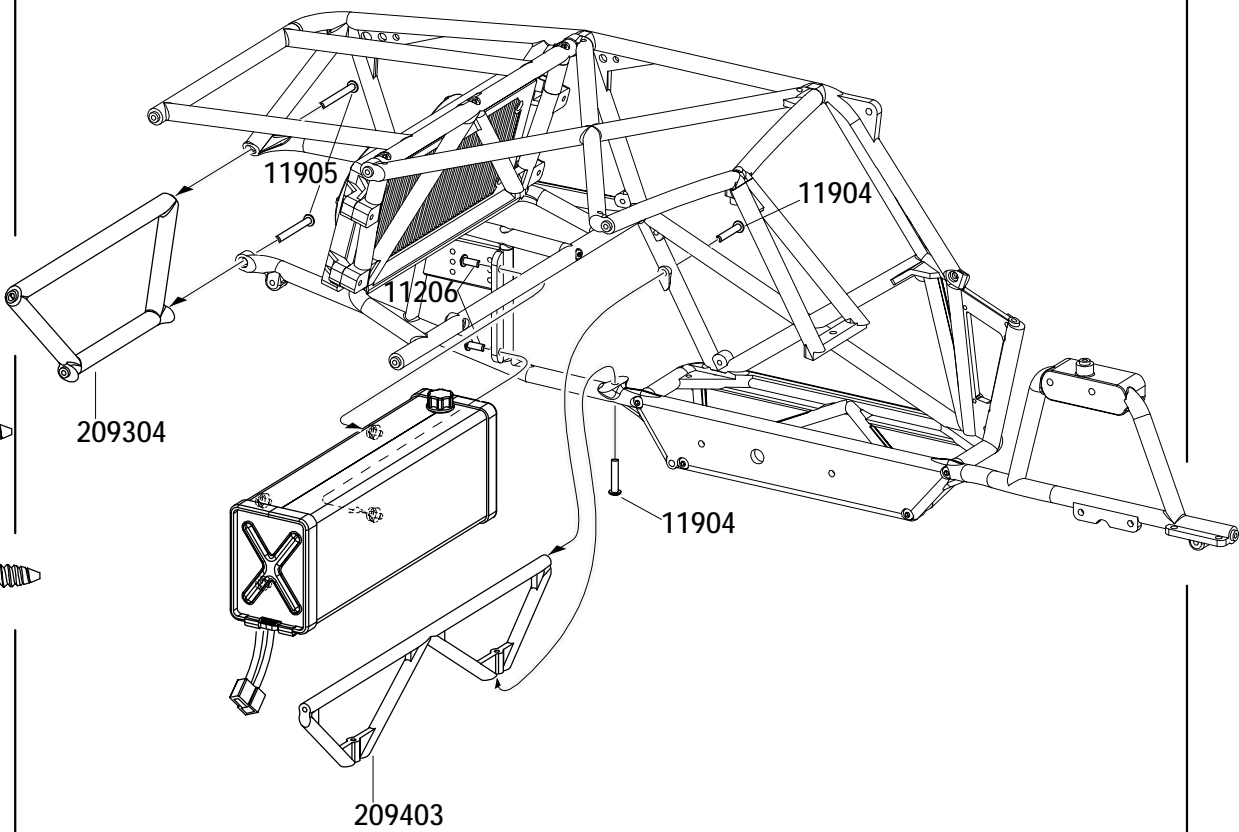

68

11904  M3x16 X5

11905  M3x20 X3

11206  M3x8 X2

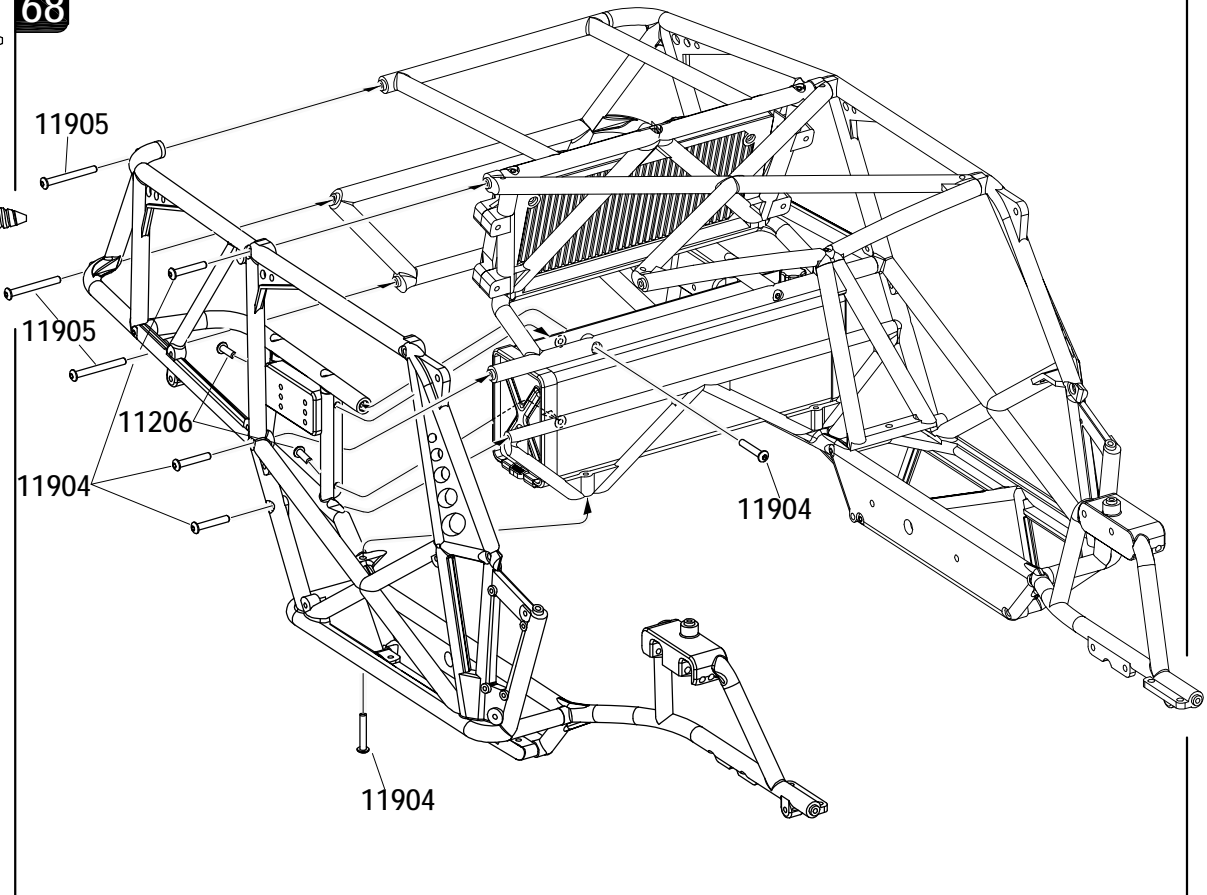

69

11904  M3x16 X6

11206  M3x8 X4

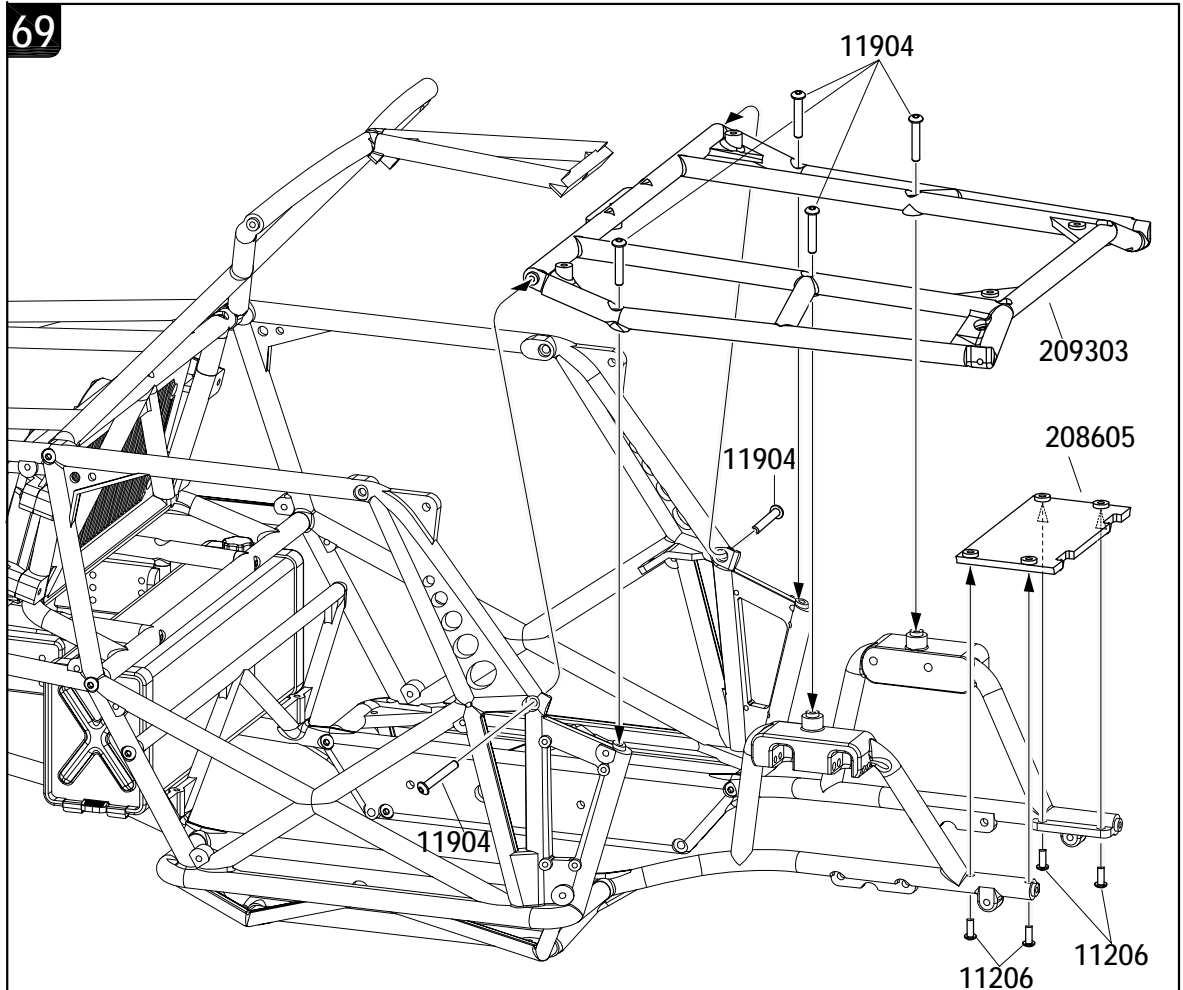

70

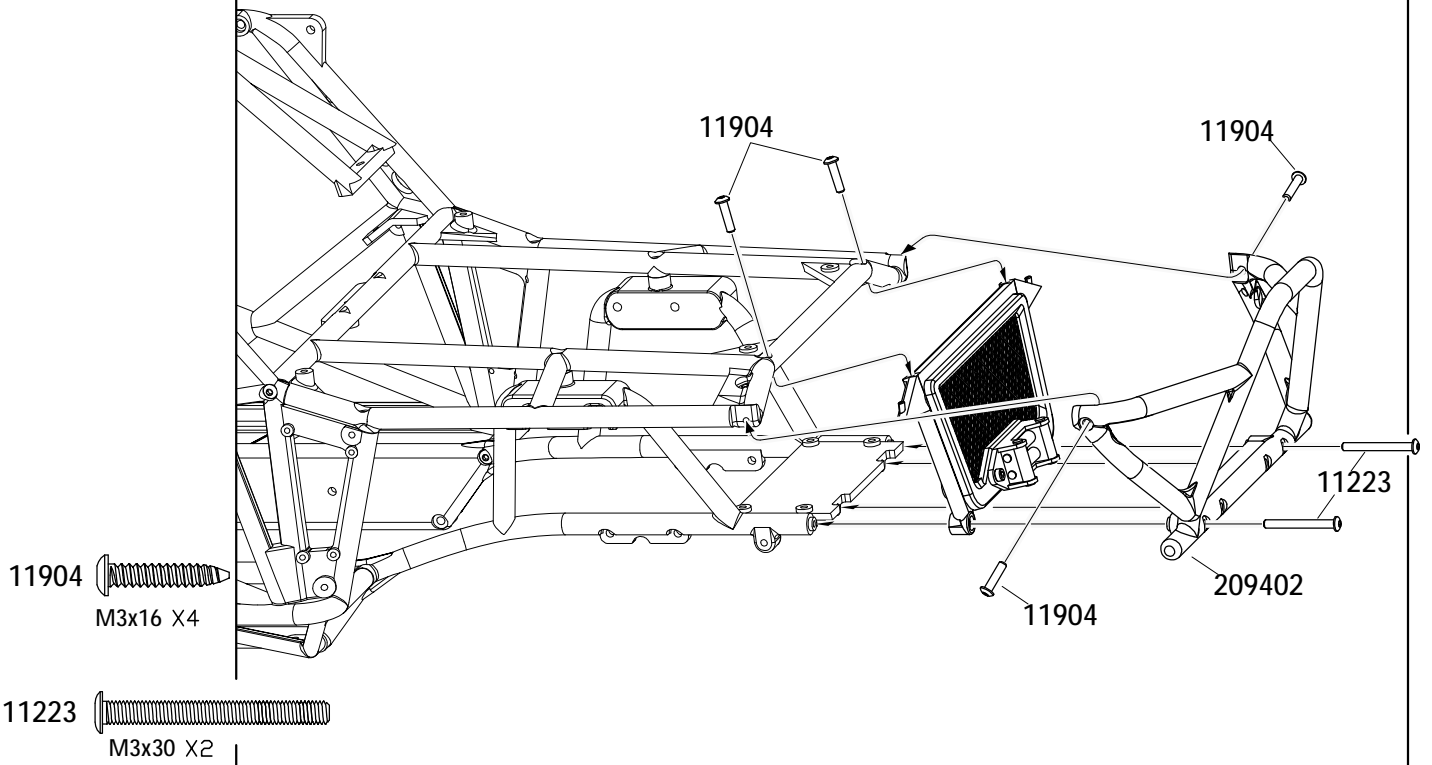

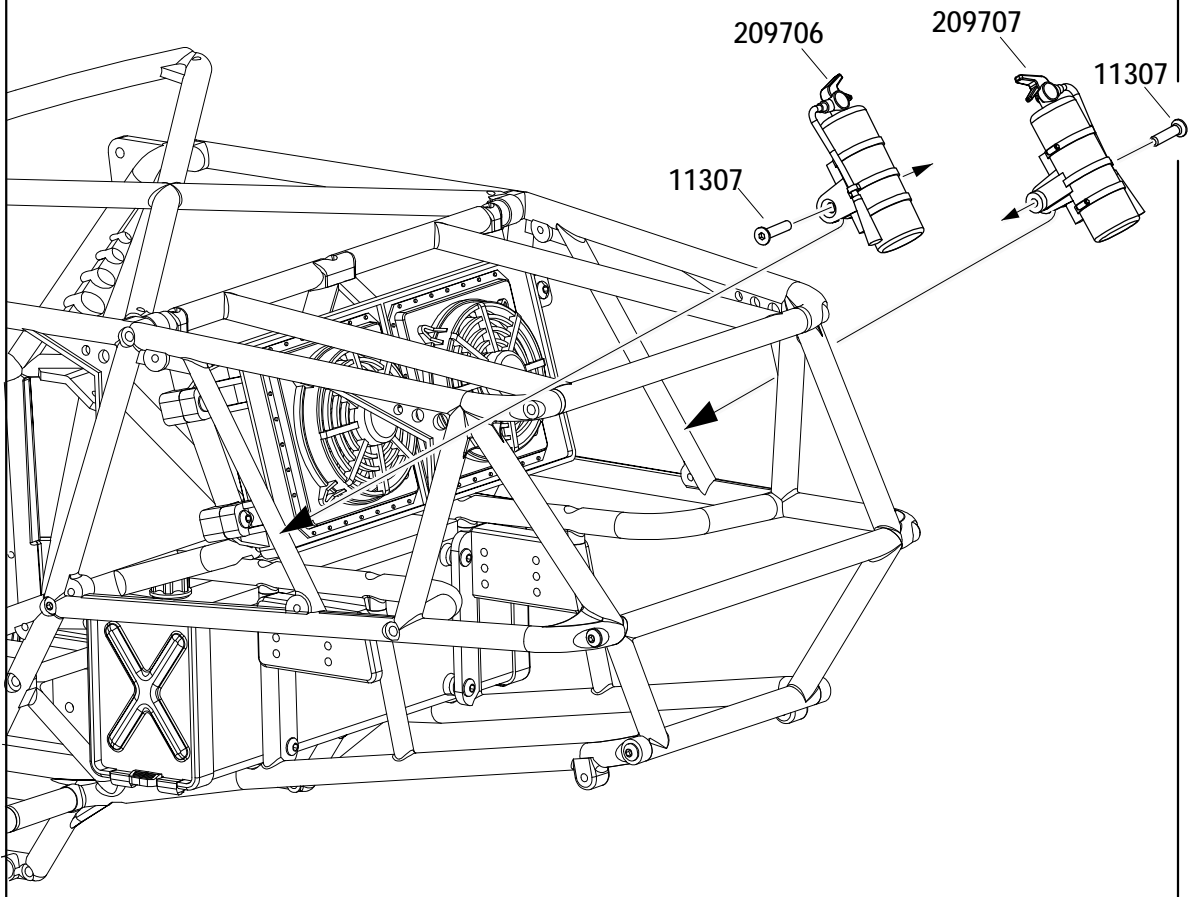

71

11307
M3x14 X2



72

11223 
M3x30 X2

11112 
M3x20 X1

11107 
M3x10 X4

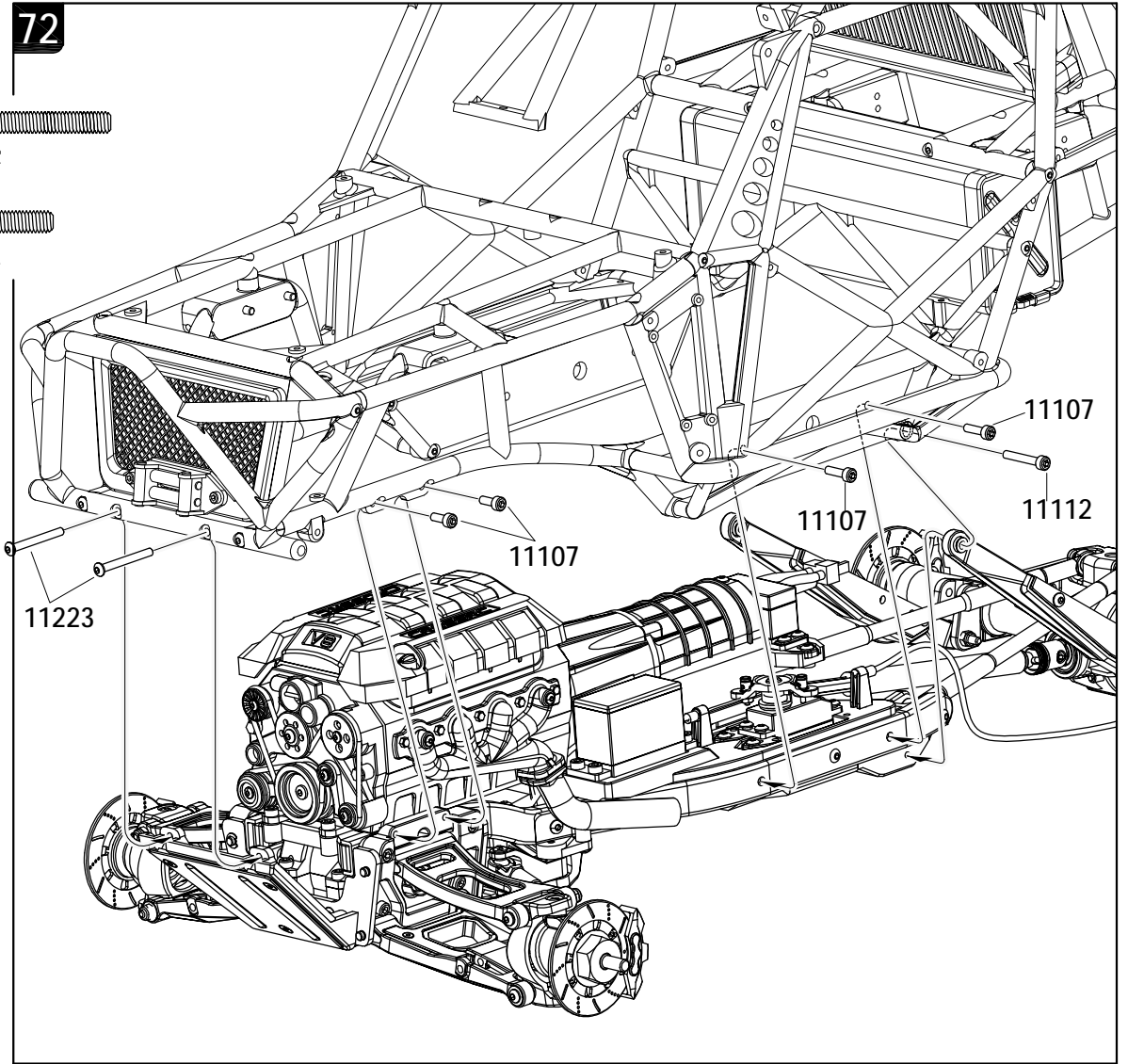

73

11112 
M3x20 X1

11107 
M3x10 X4

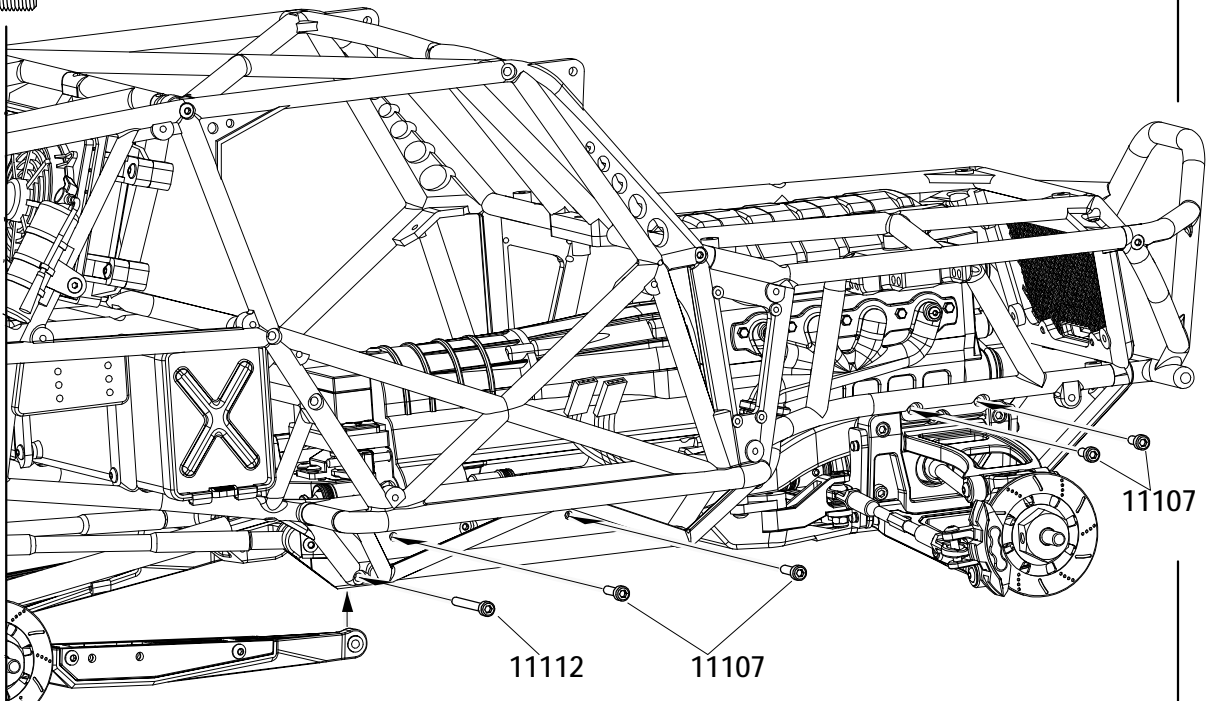

74

11123
M3x45 X2

11123

11210
M3x16 X2

11212
M3x20 X2

11113
M3x22 X2

11210

209207

12203

11212

11113

12203
M3 X2

75

12203

209207

11212

11113

11210

11123

76

Receiver
(Not included)

ESC
(Not included)

85018
85008

85018
85008

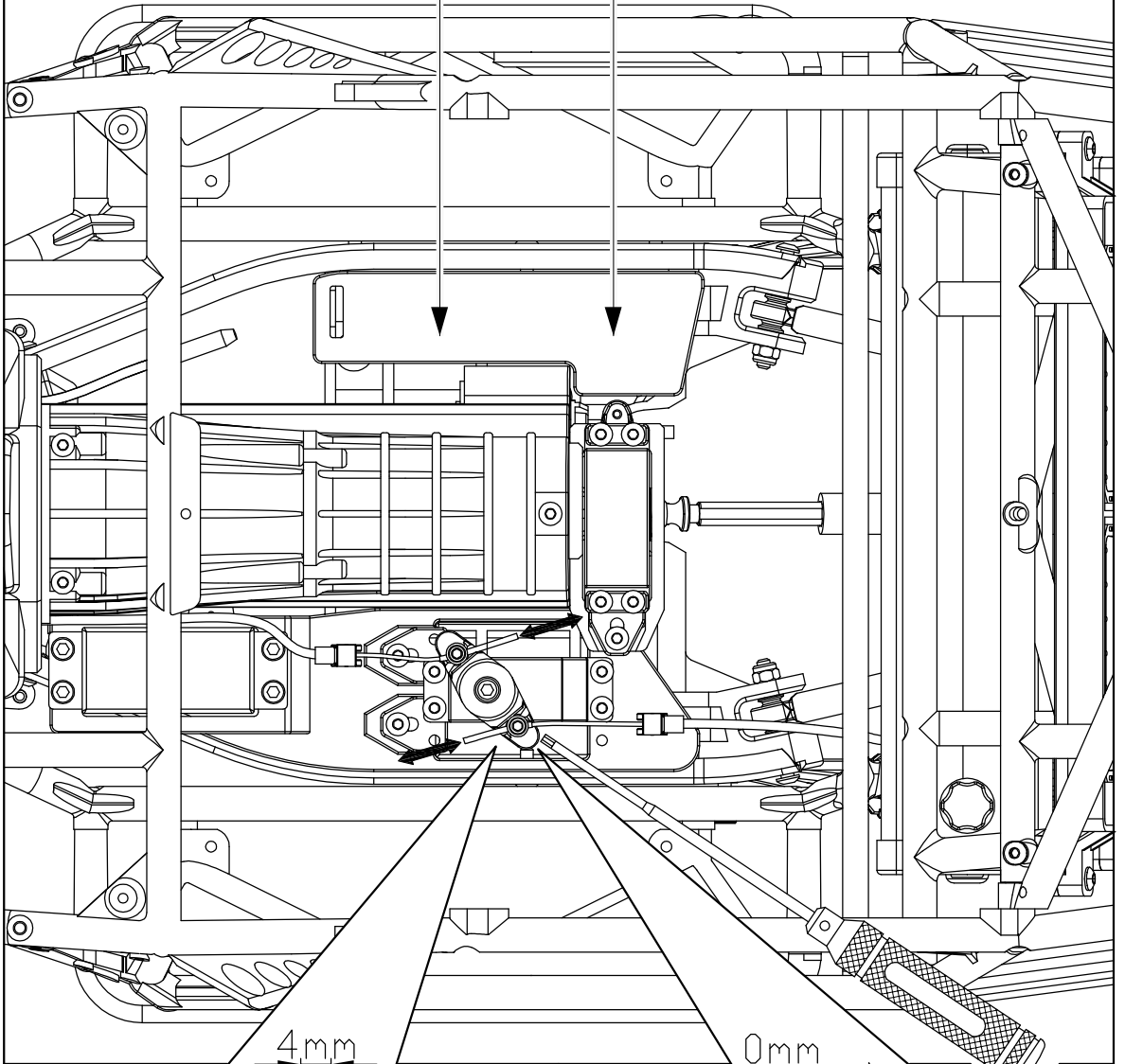

4mm

0mm

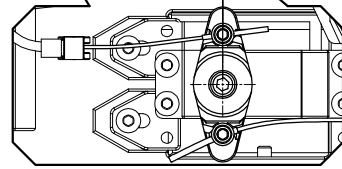
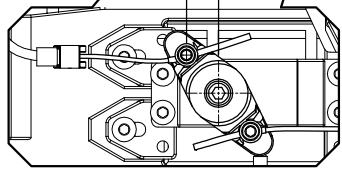

Lock

Unlock

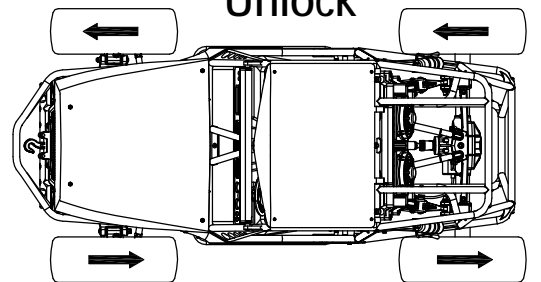
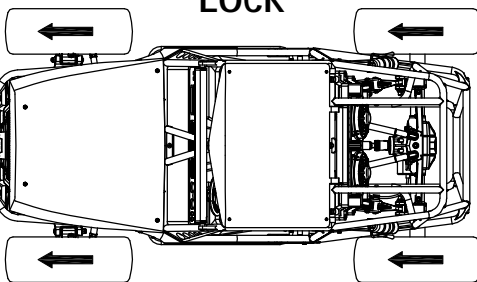

77

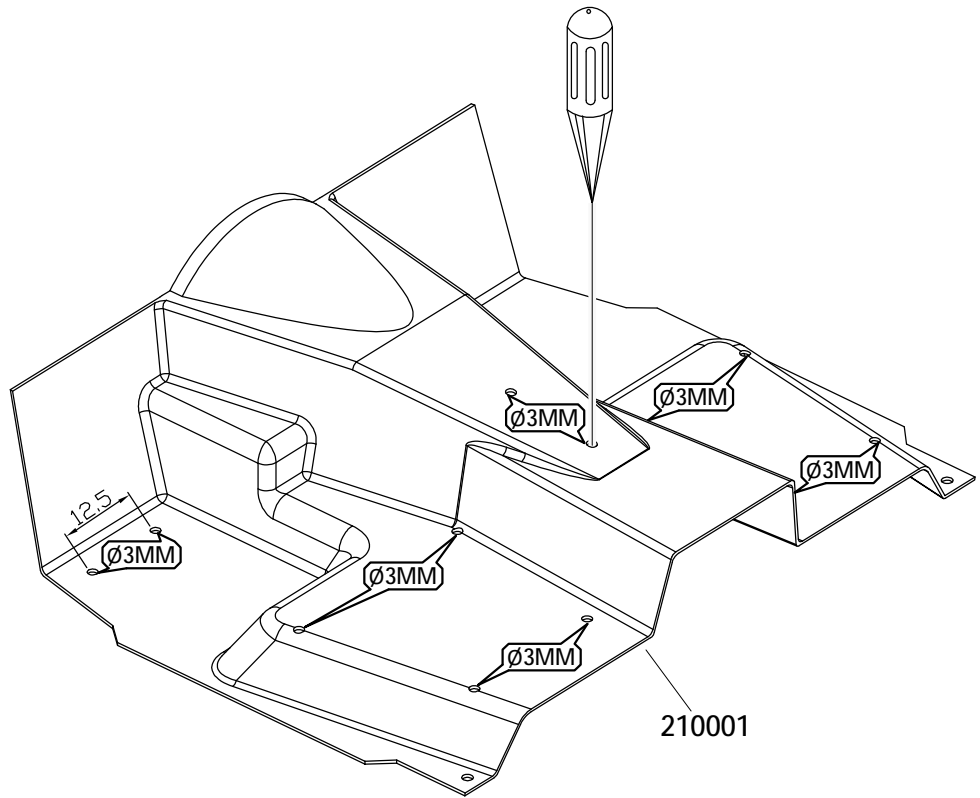

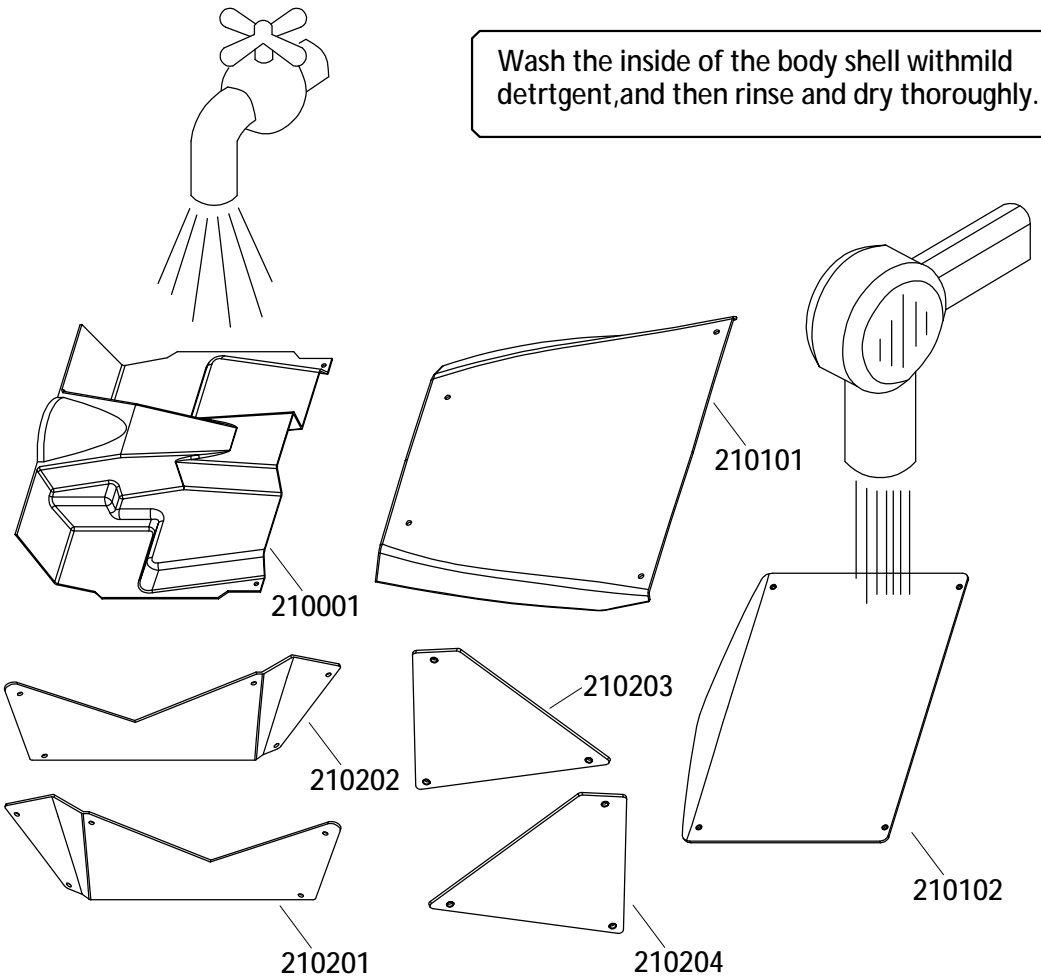

78

Wash the inside of the body shell with mild detergent, and then rinse and dry thoroughly.

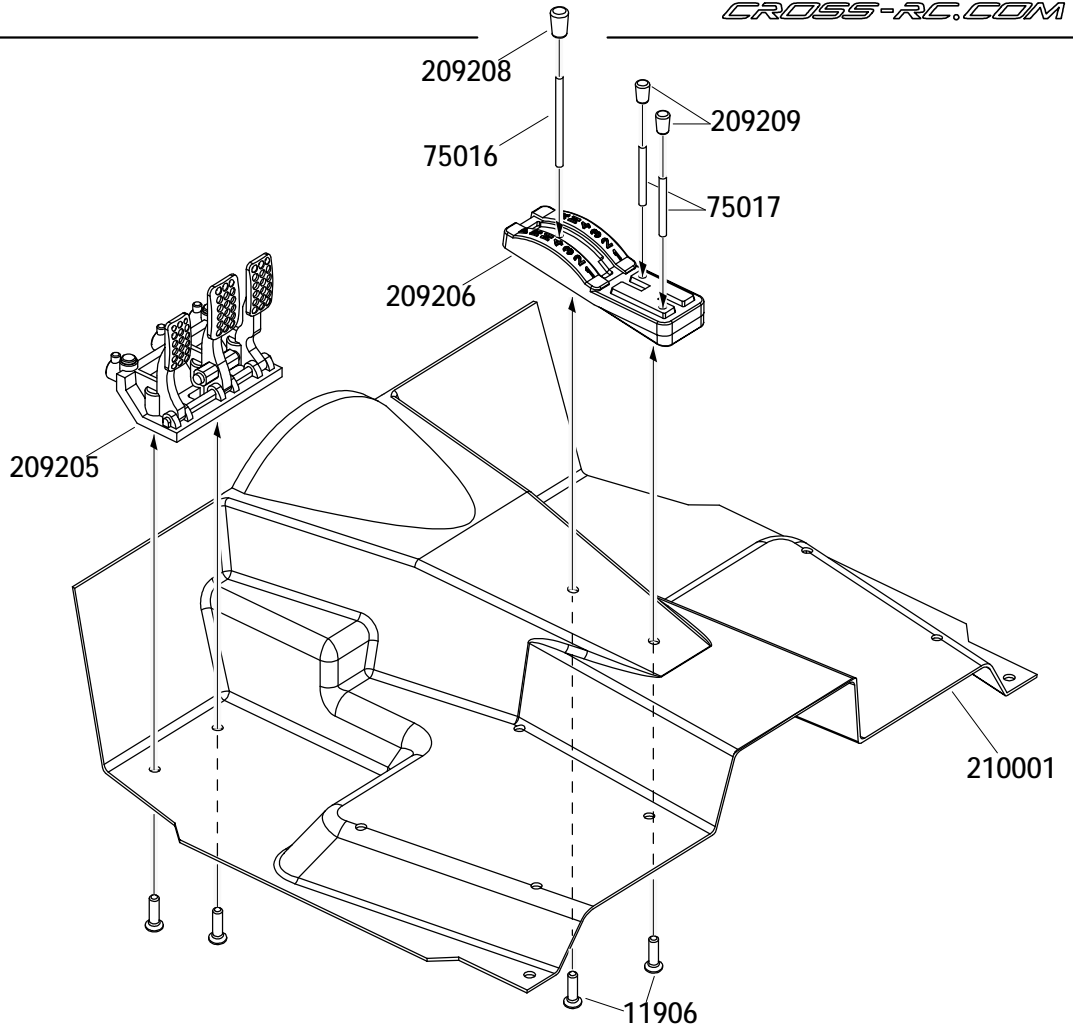

79



11906 
M3x8 X4

80

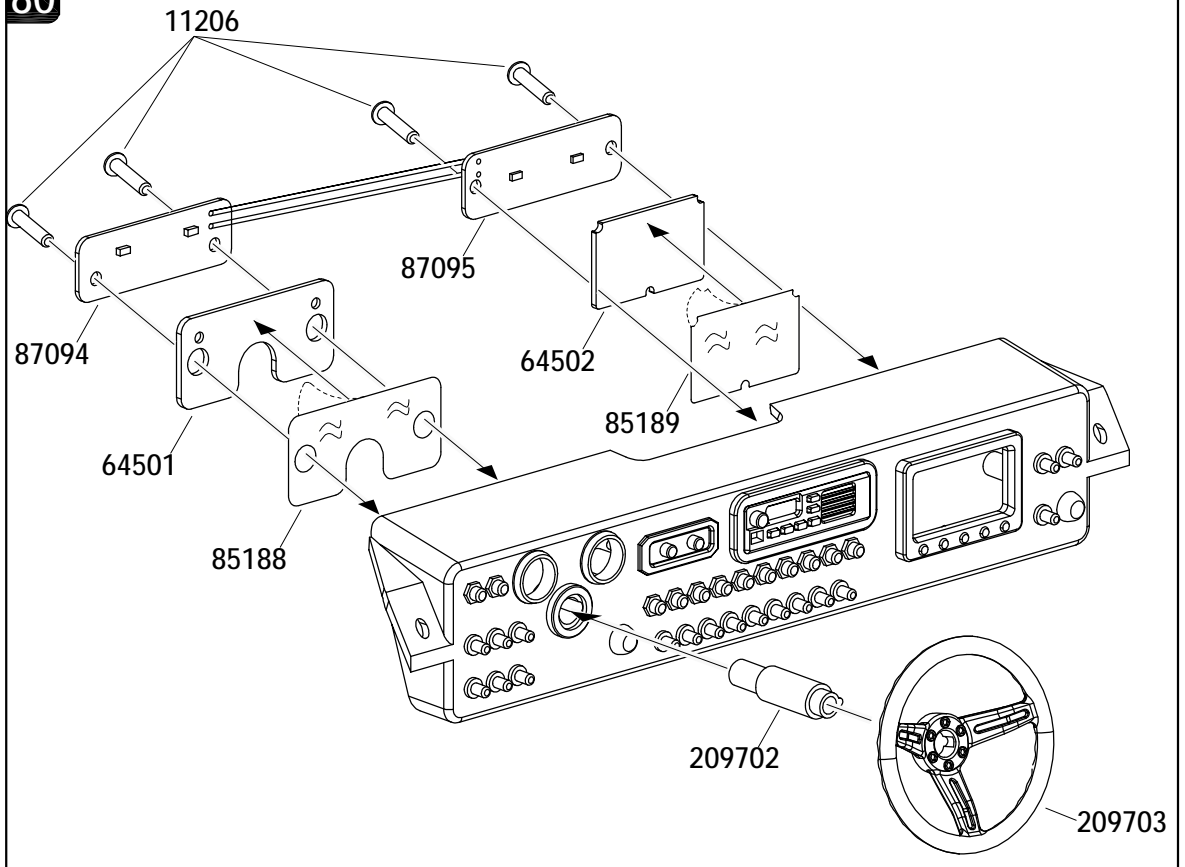

11206 
M3x8 X4



81

11307 
M3x14 X4

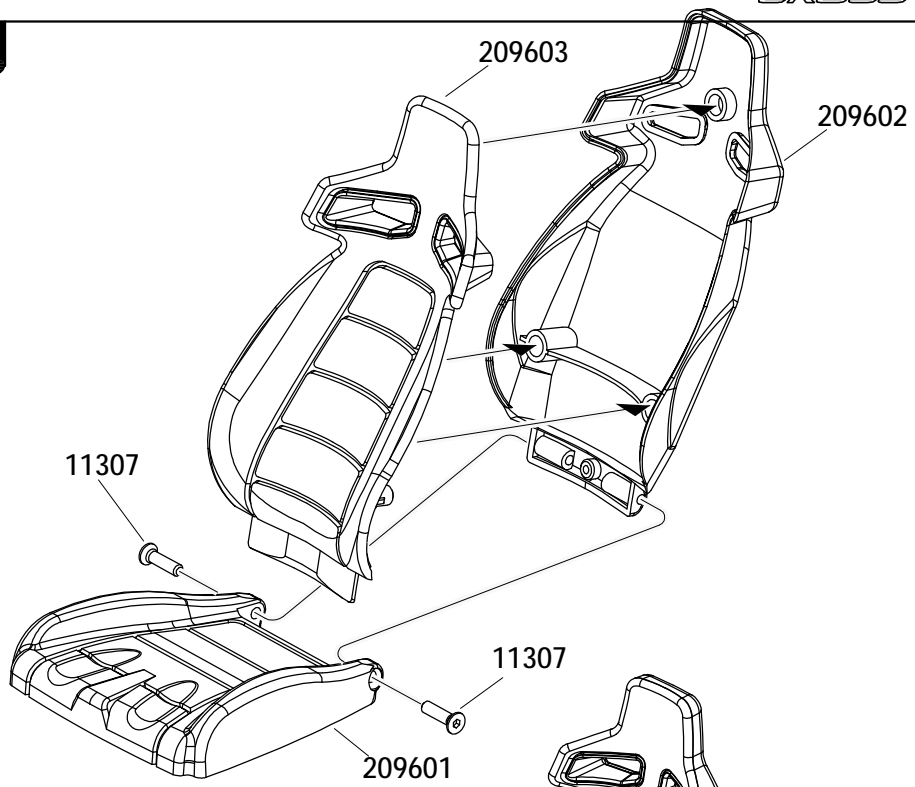

82

11903 
M3x10 X8

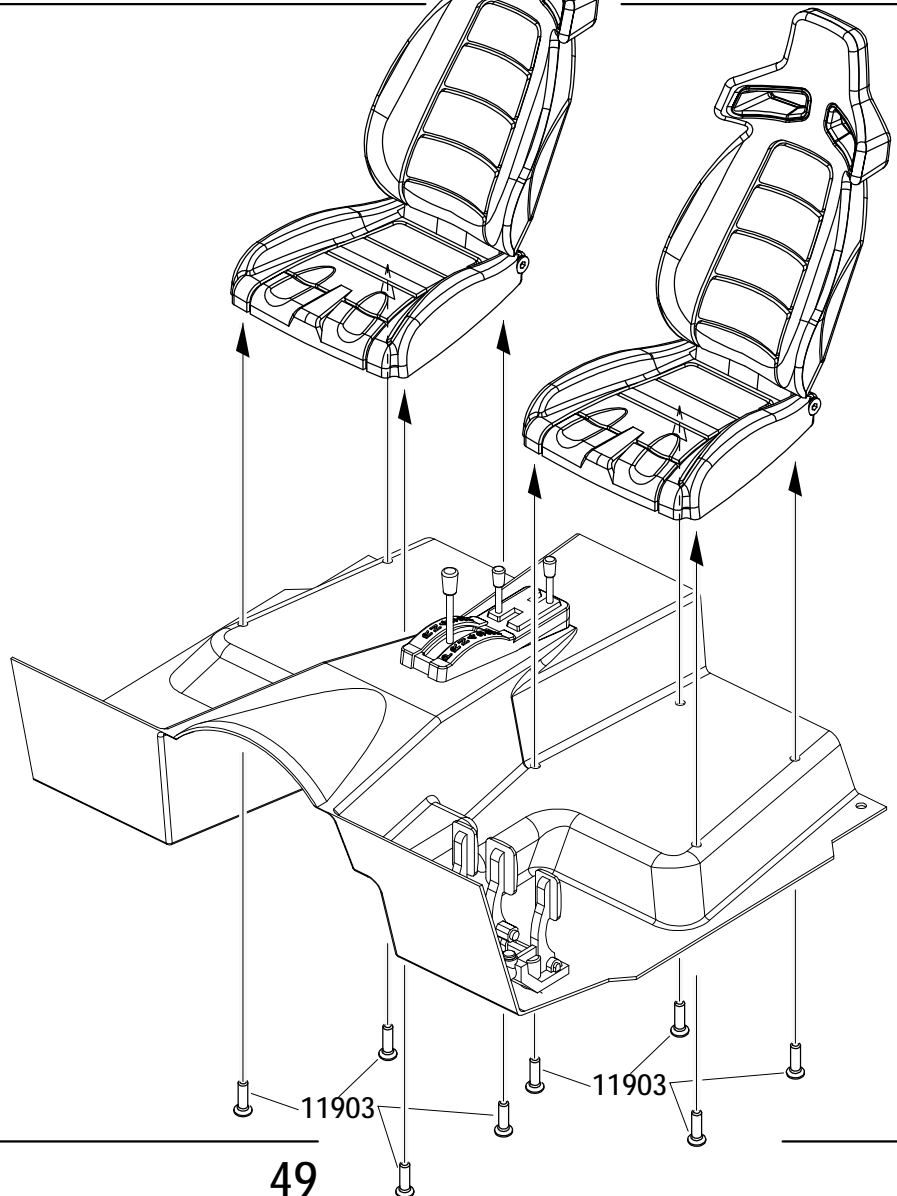

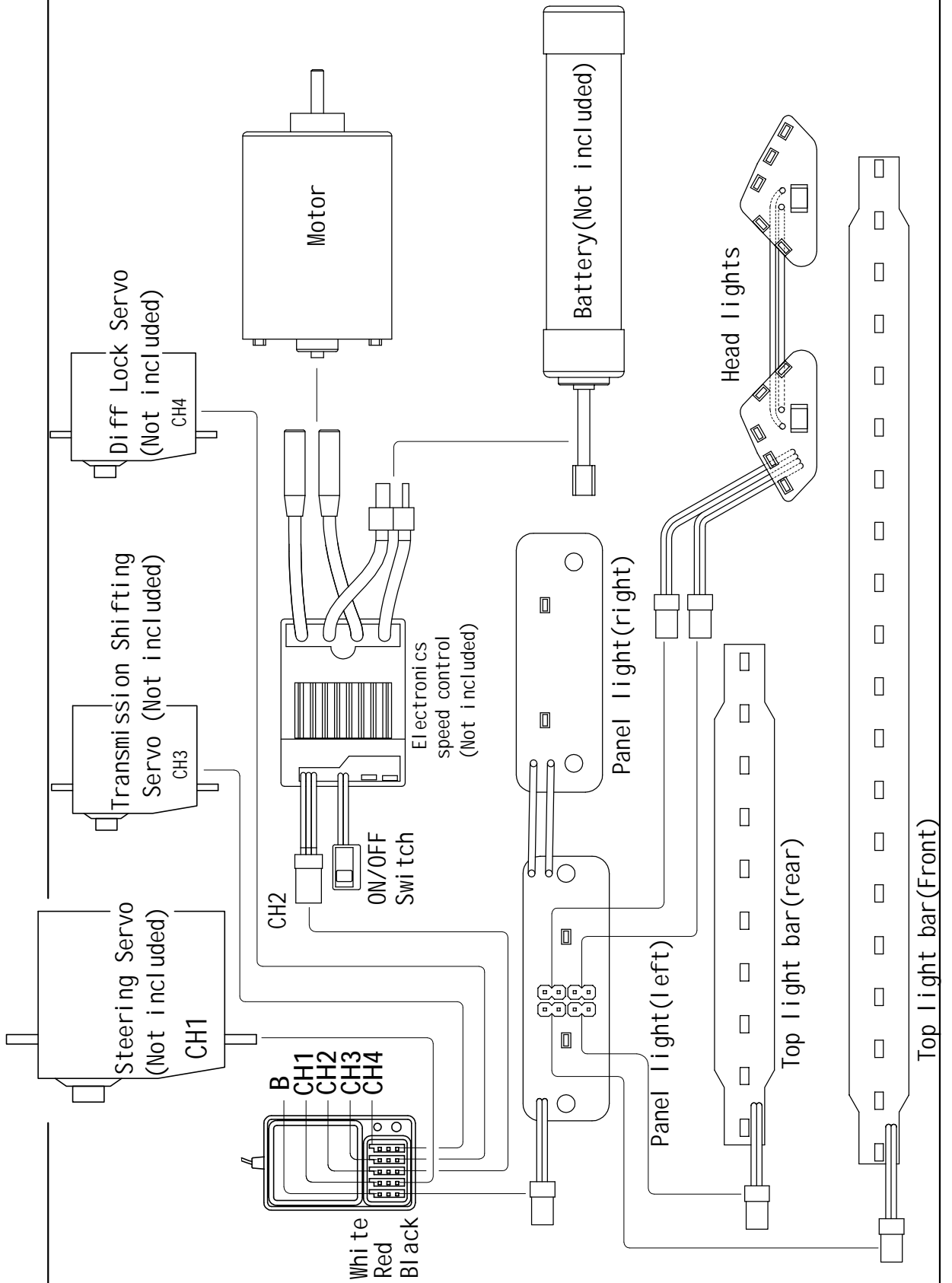

84

11104  M2x10 X4

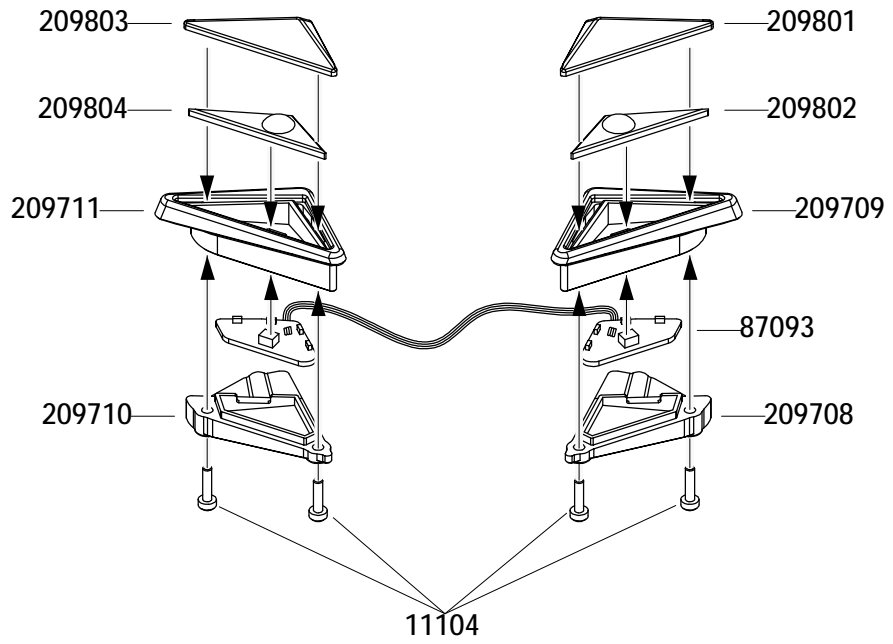

85

11109  M3x14 X2

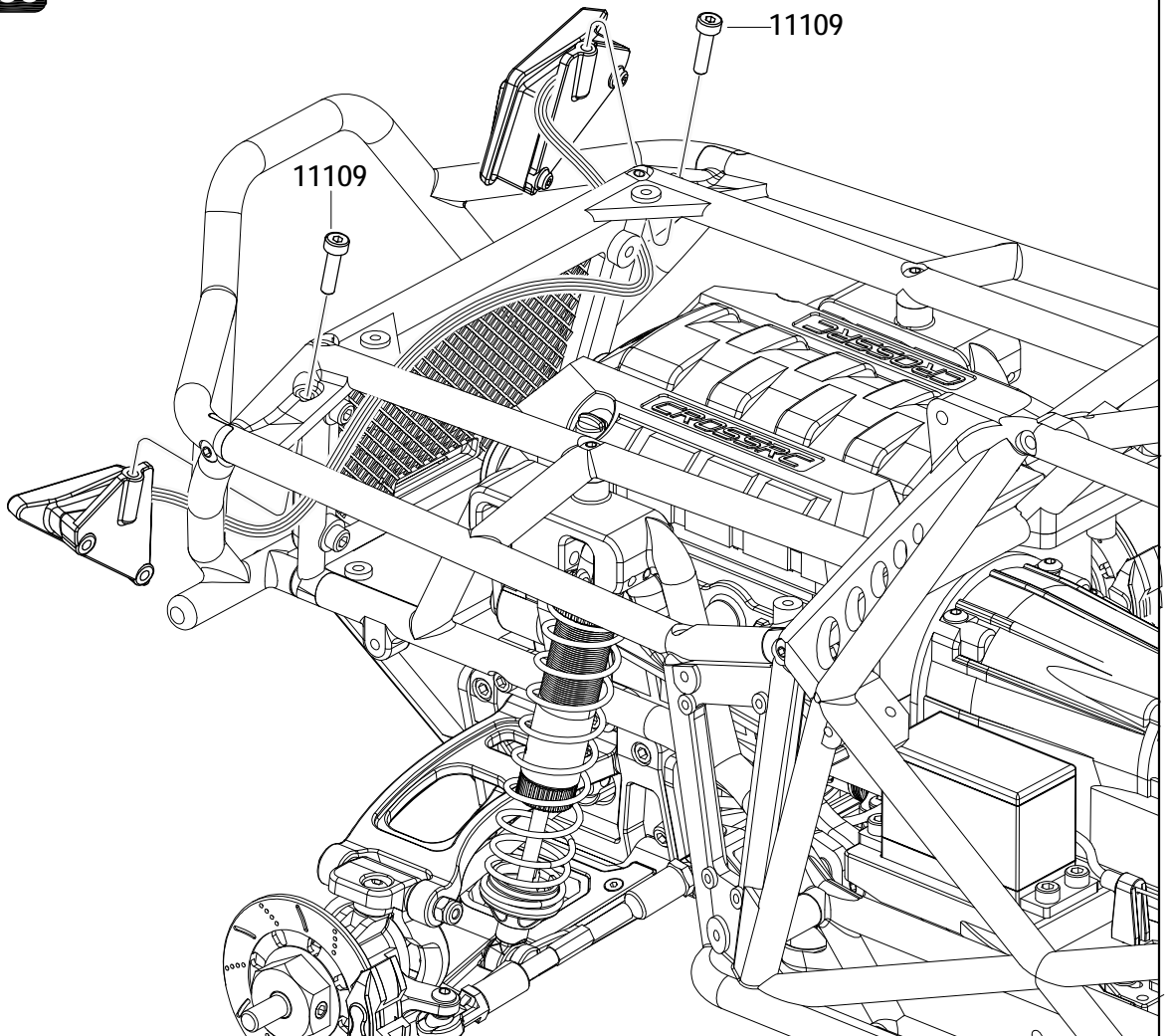

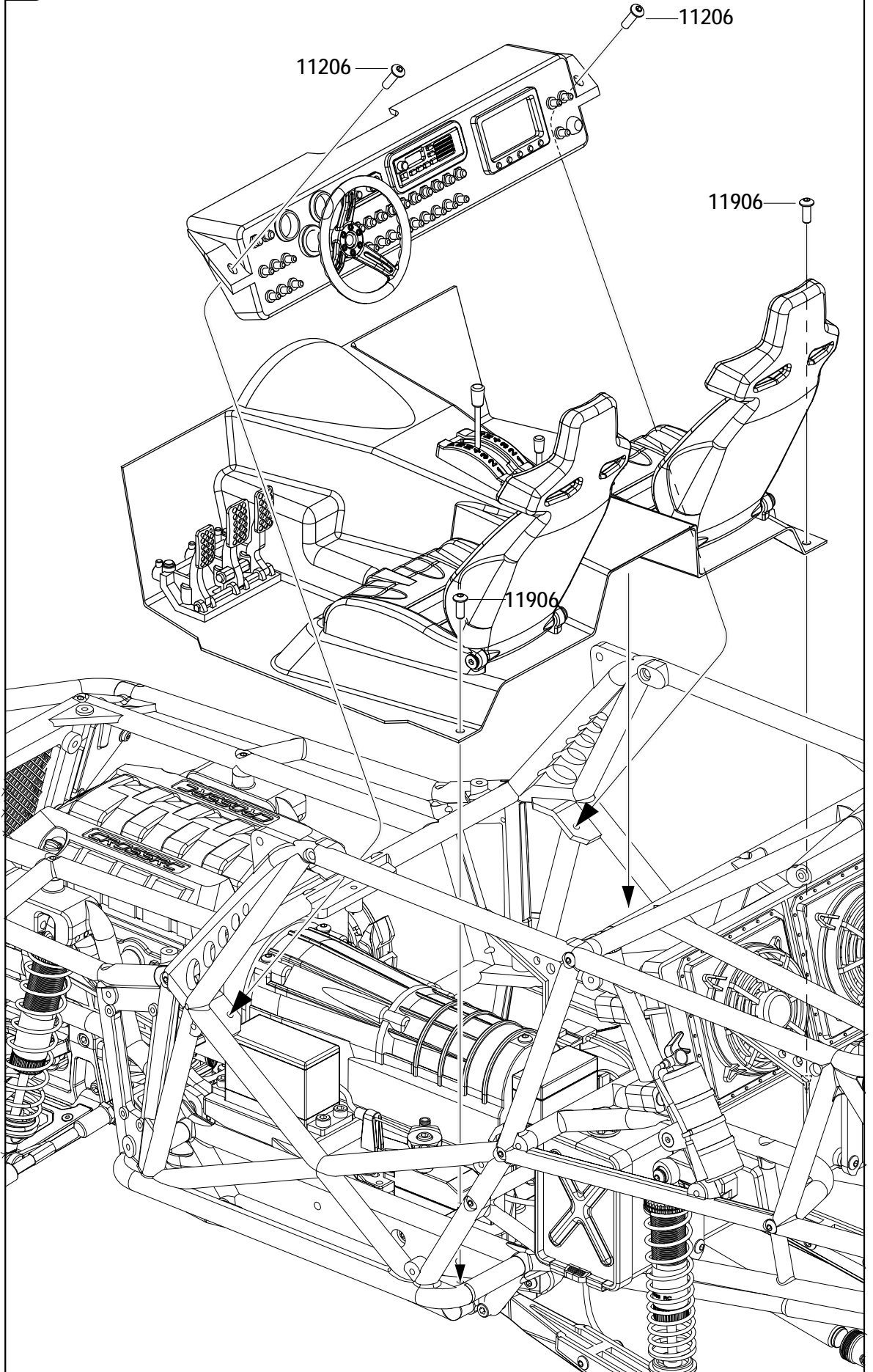

11206 
M3x8 X4

11906 
M3x8 X2

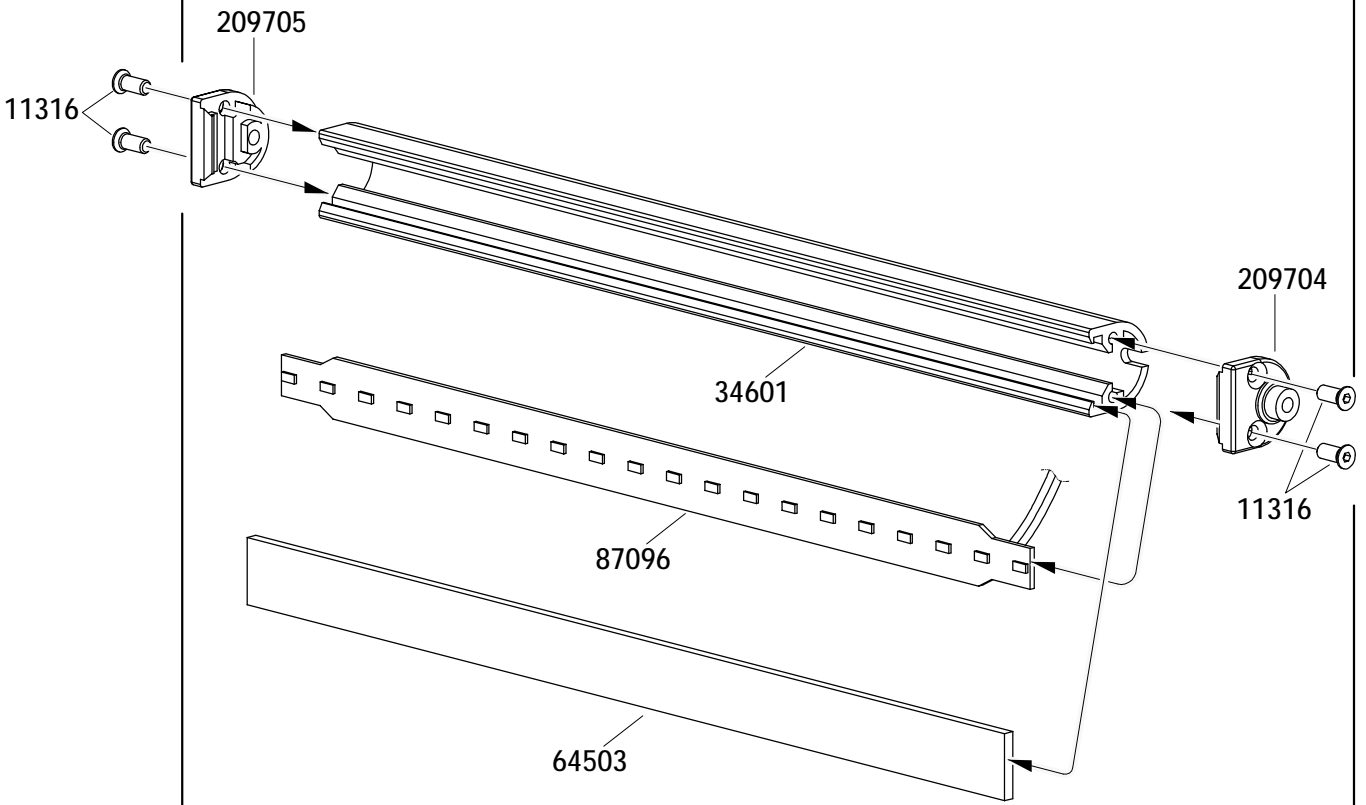

87



11316 
M2.5x10 X8

88

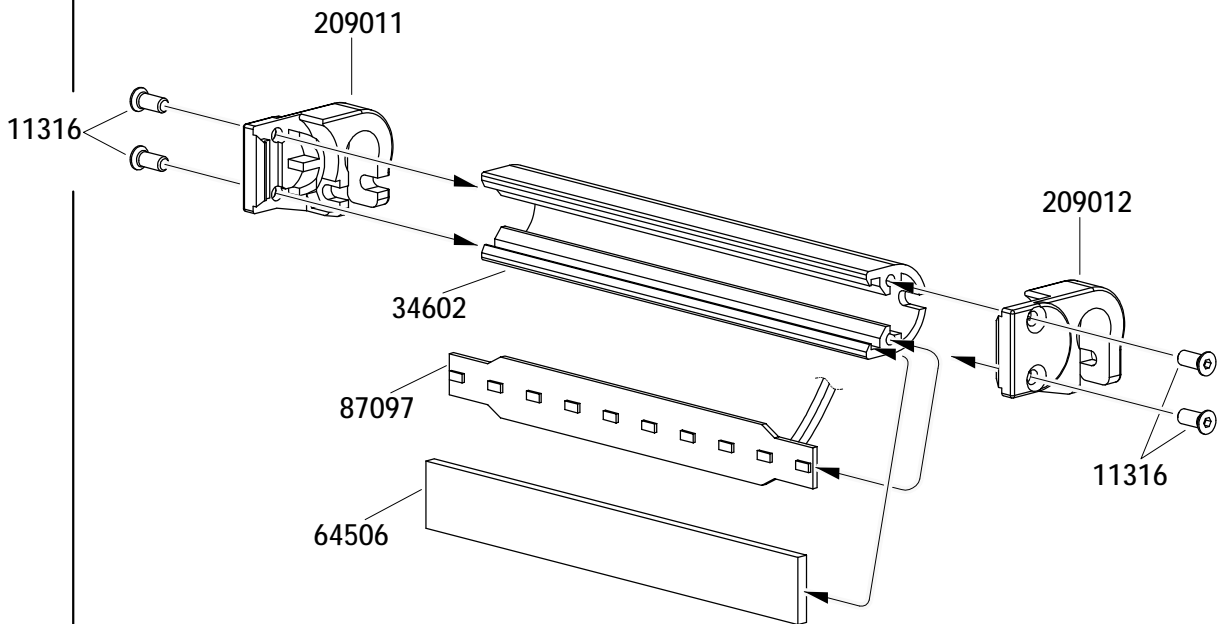

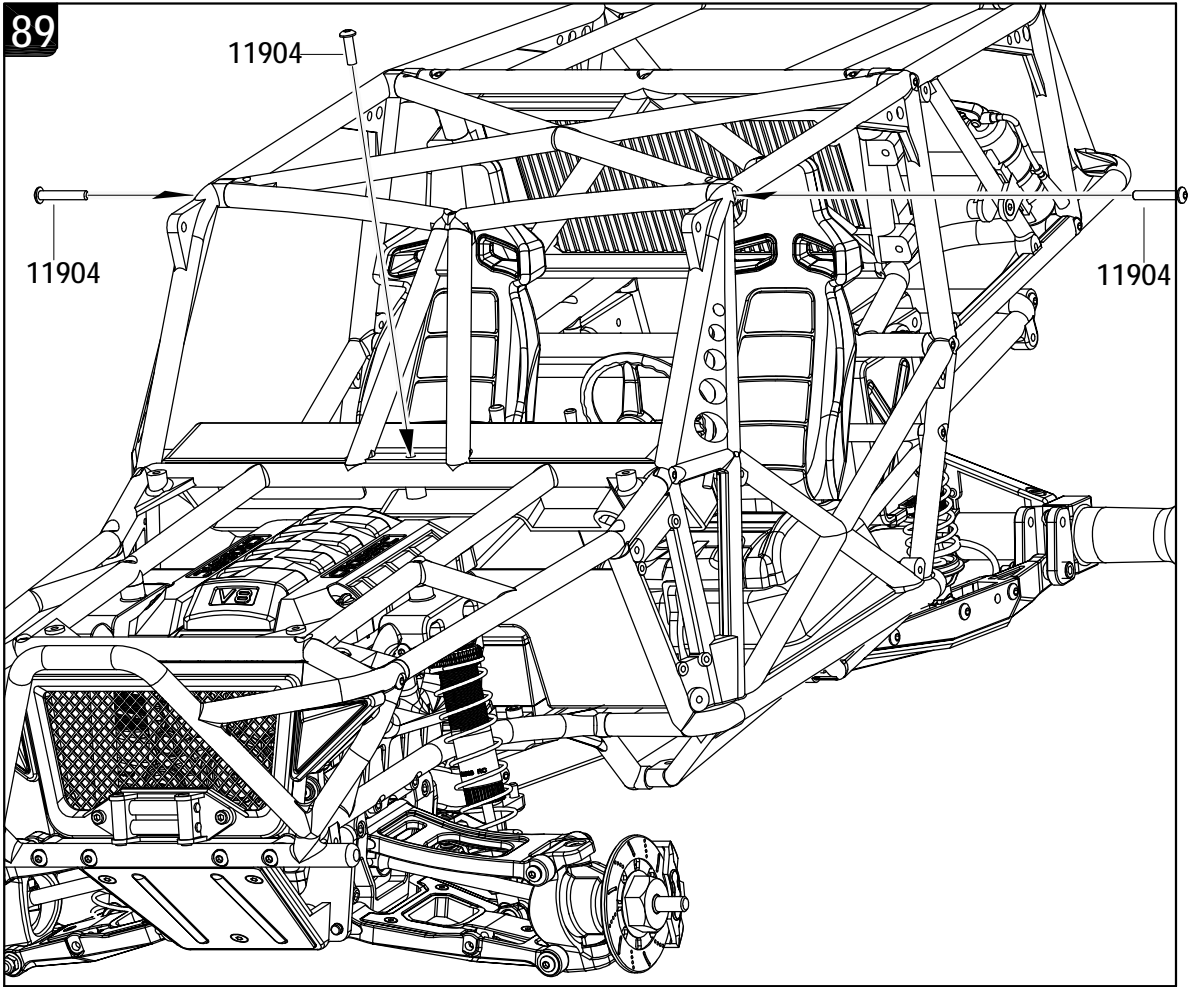

11904 
M3x16 X3

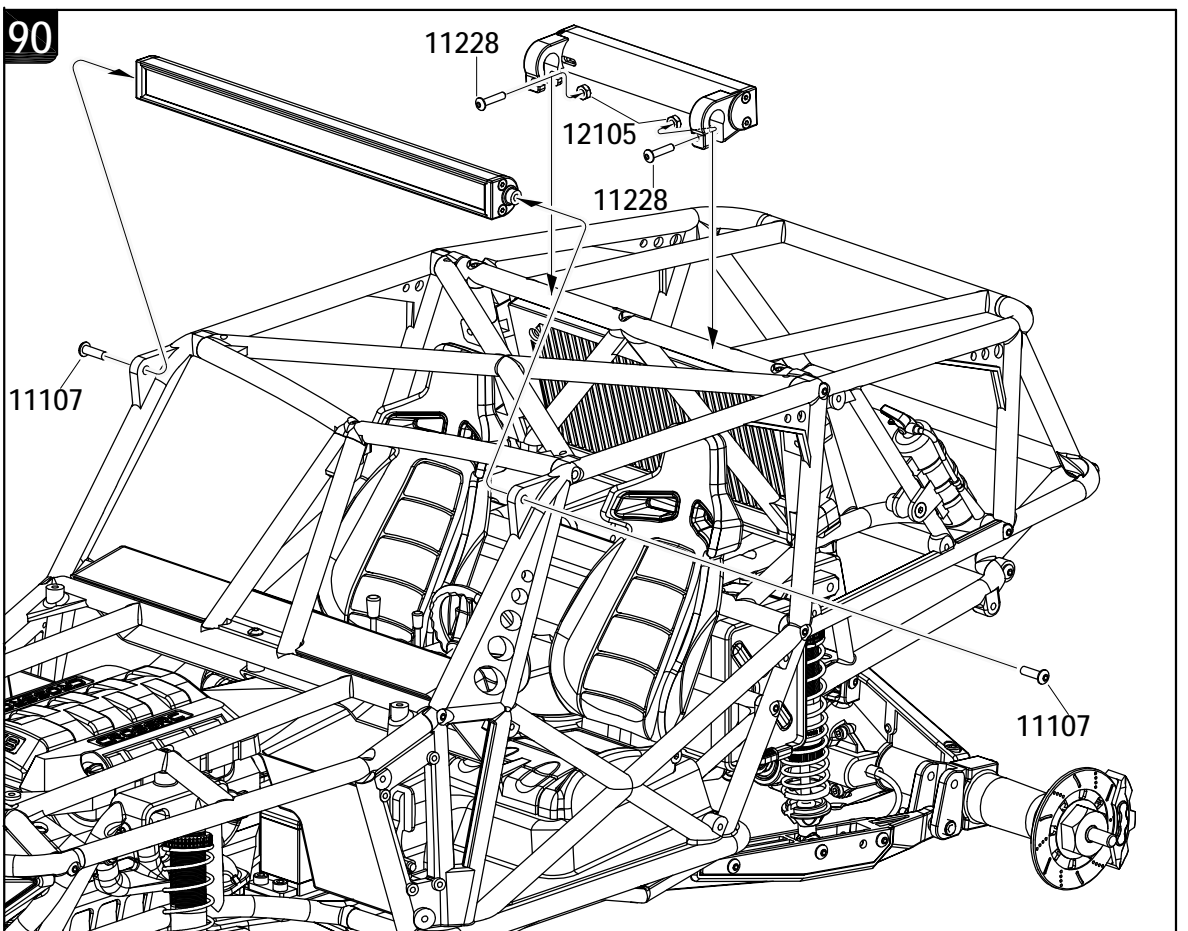



11228 
M2.5x12 X2

11107 
M3x10 X2

12105 
M2.5 X2

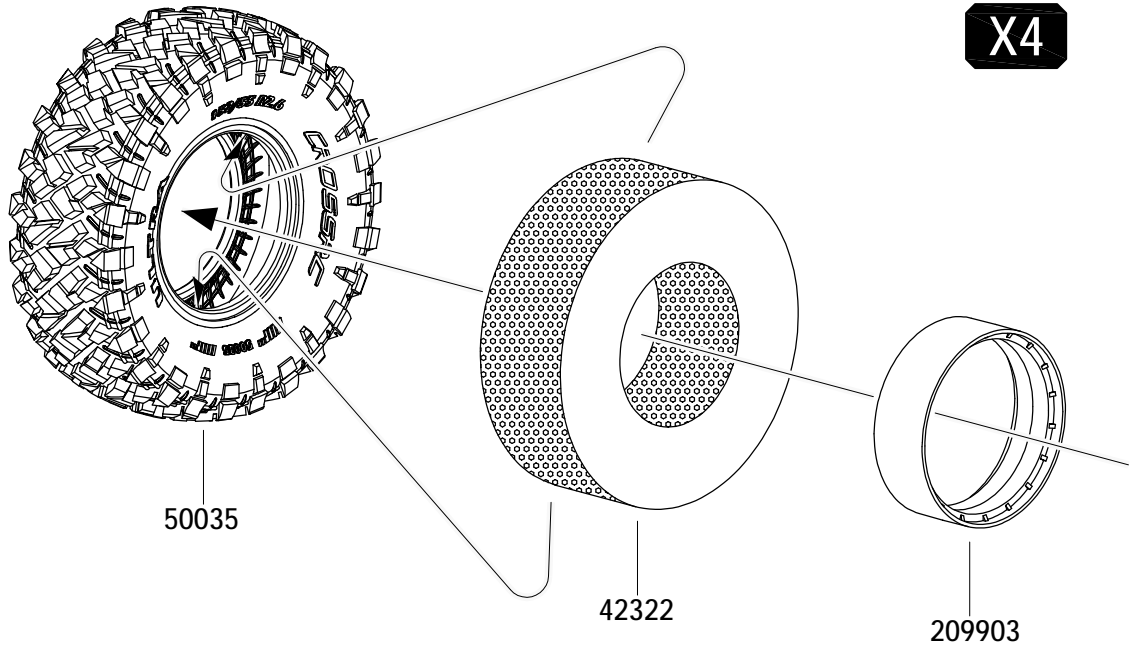
91



12203 
M3 X24

11107 
M3x10 X24

92

12103 
M3 X2

11112 
M3x20 X2

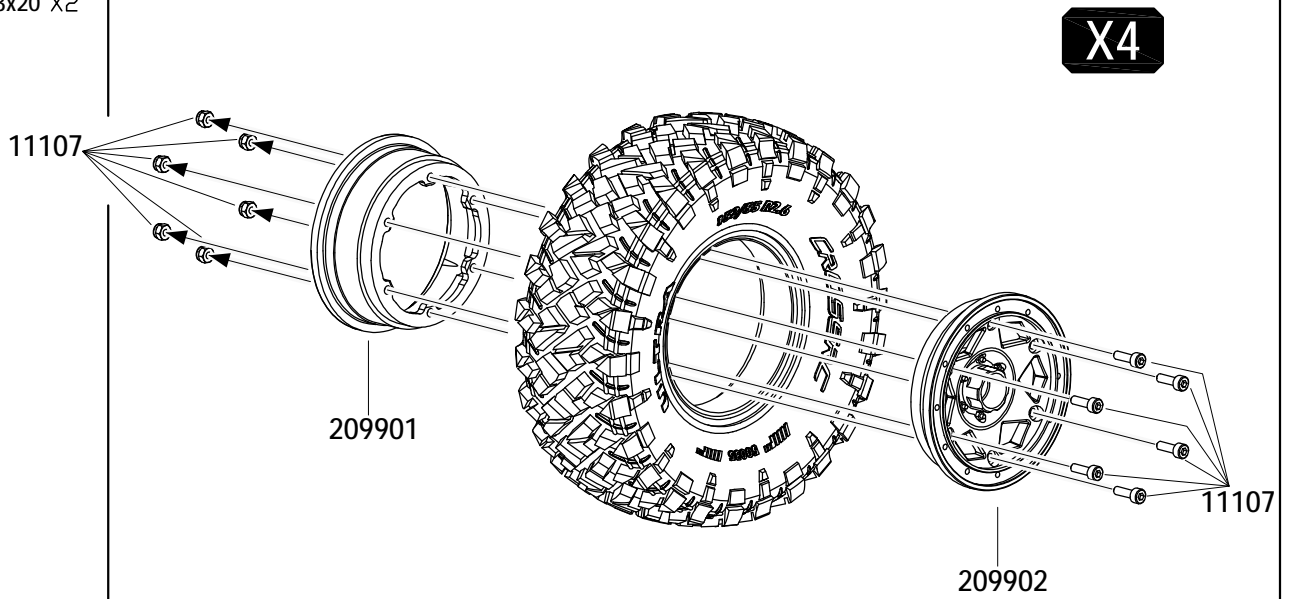

93

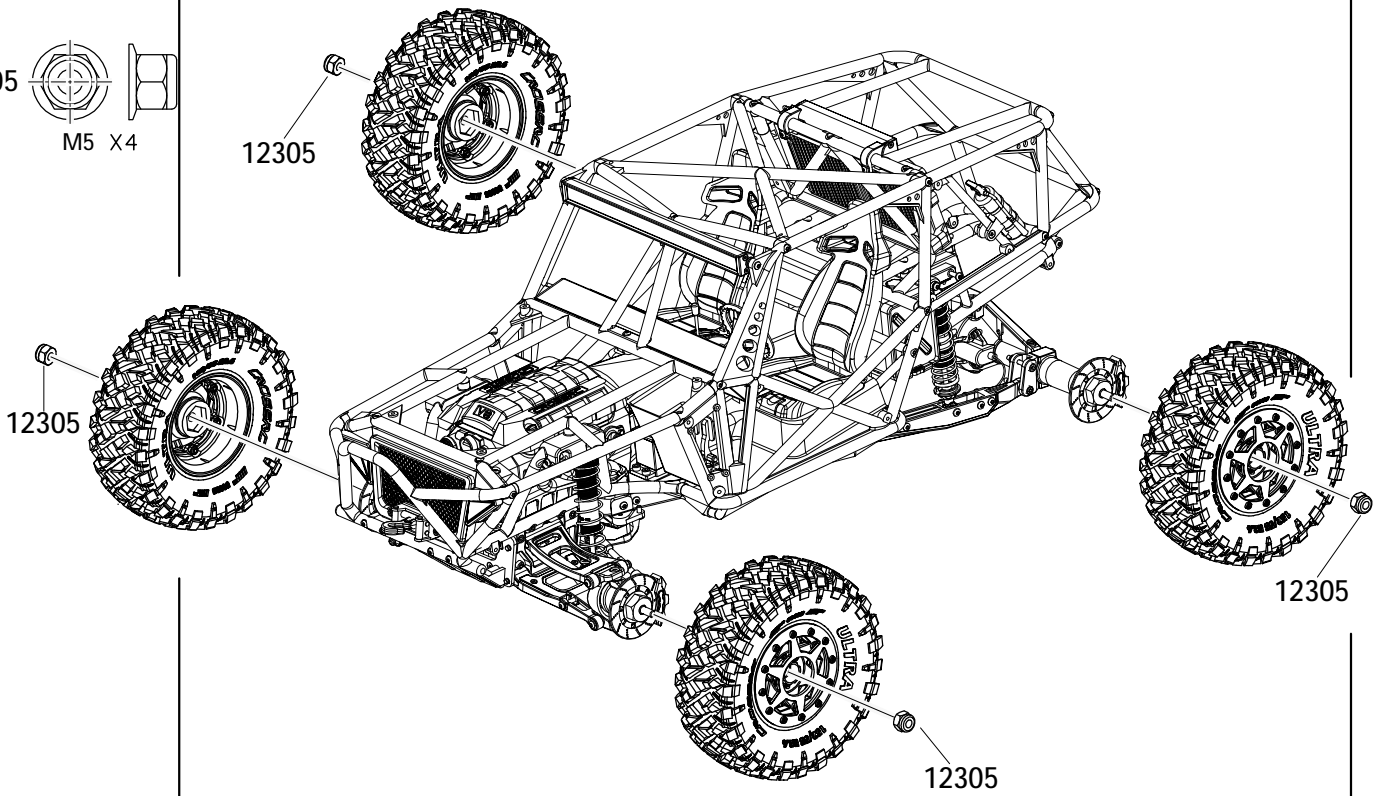

94

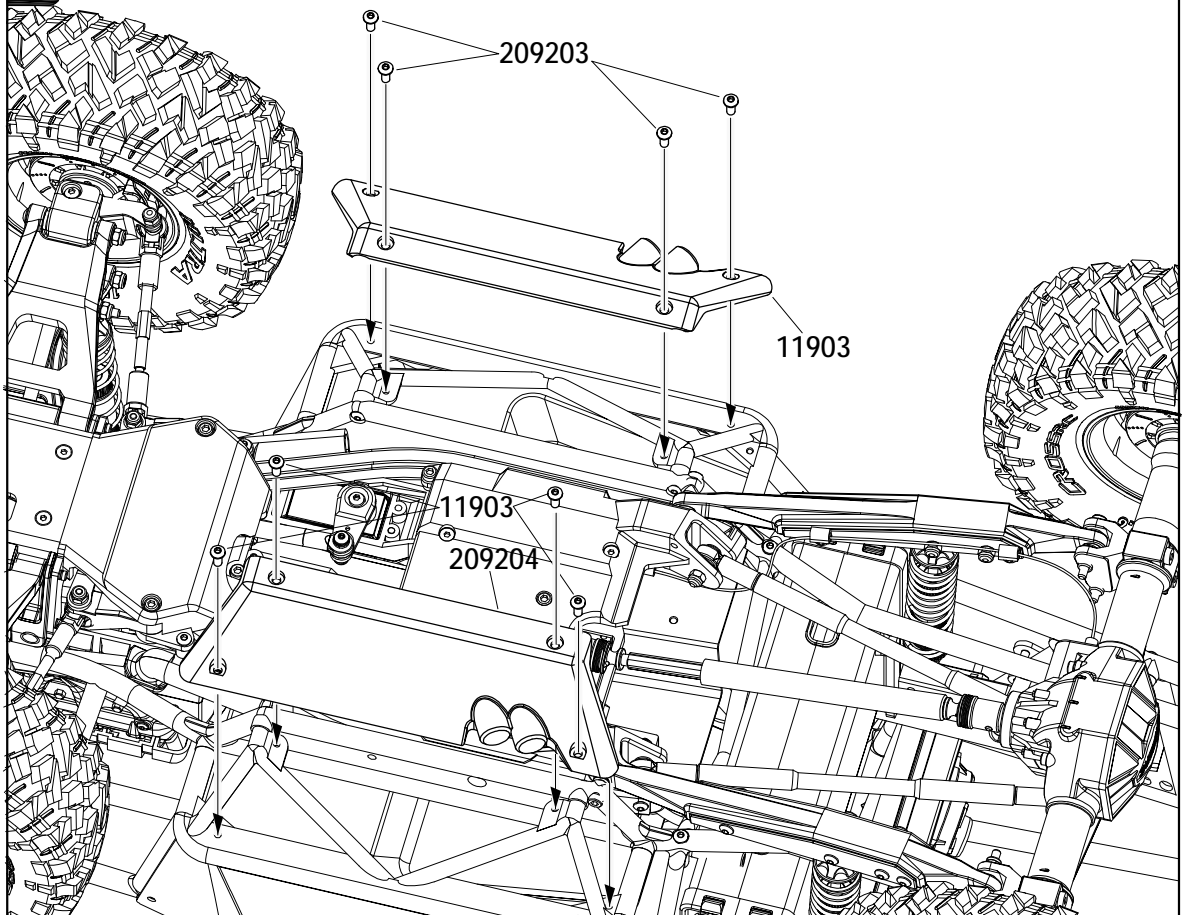
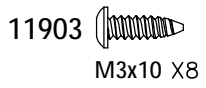

95

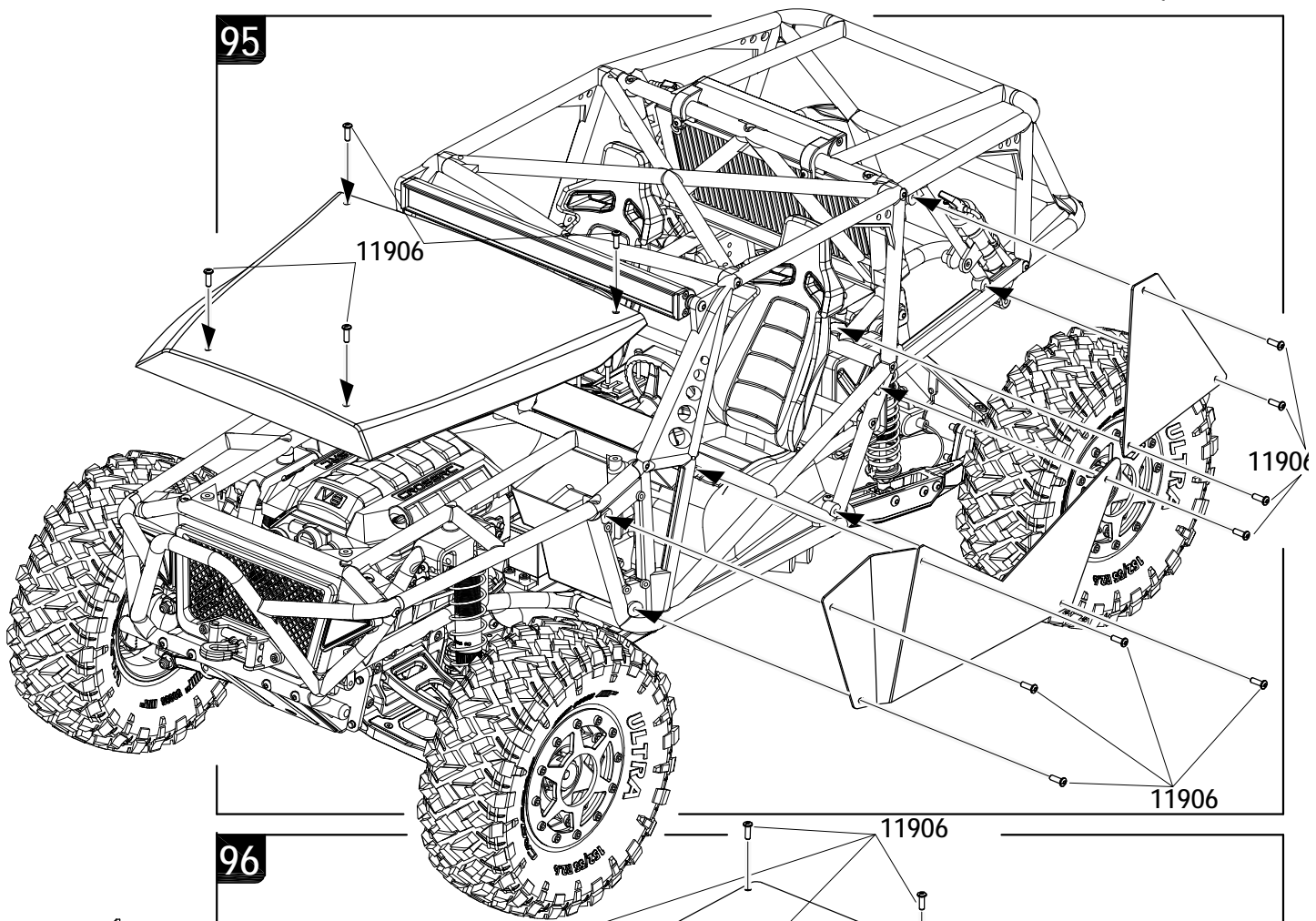

96

11906 
M3x8 X24

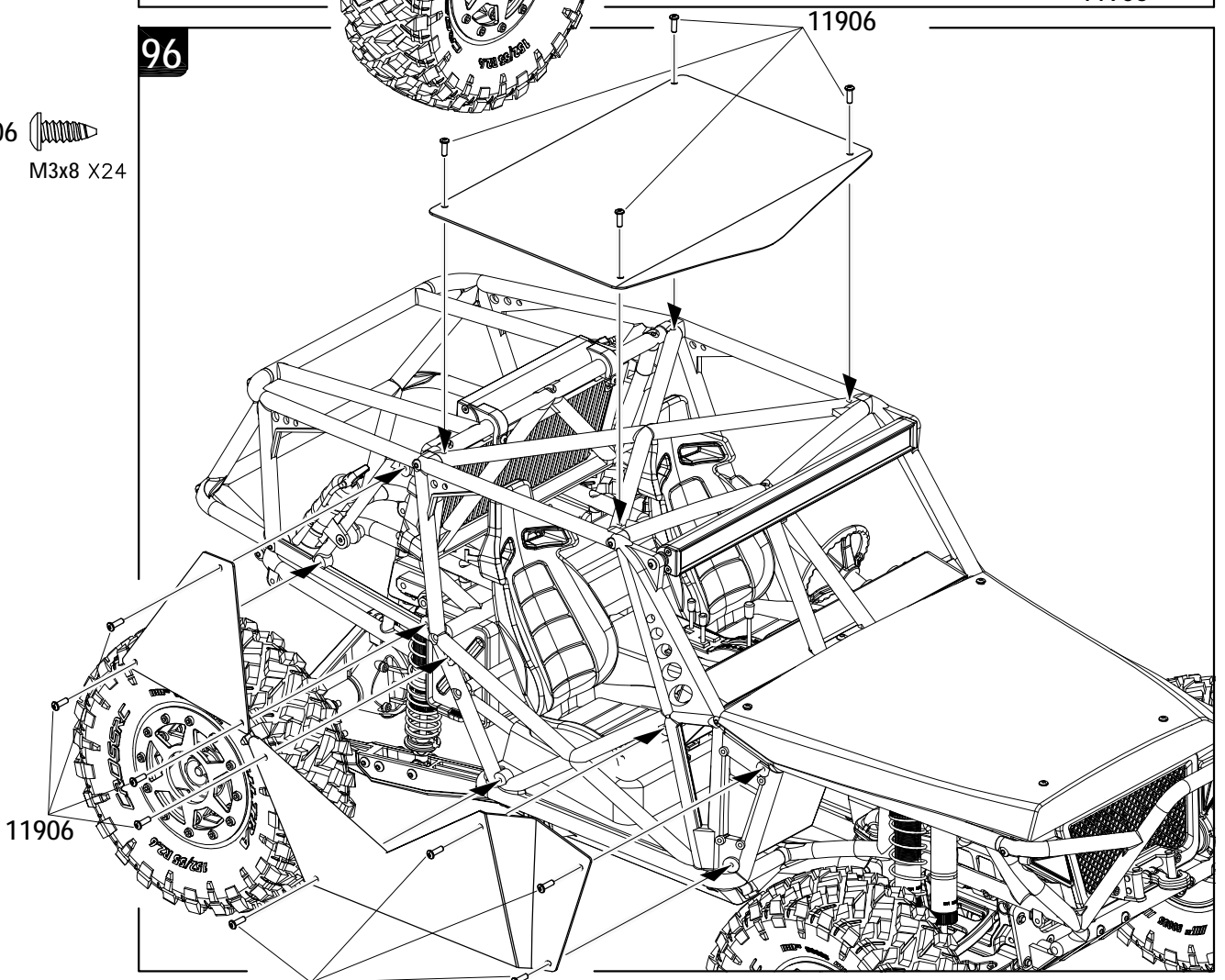

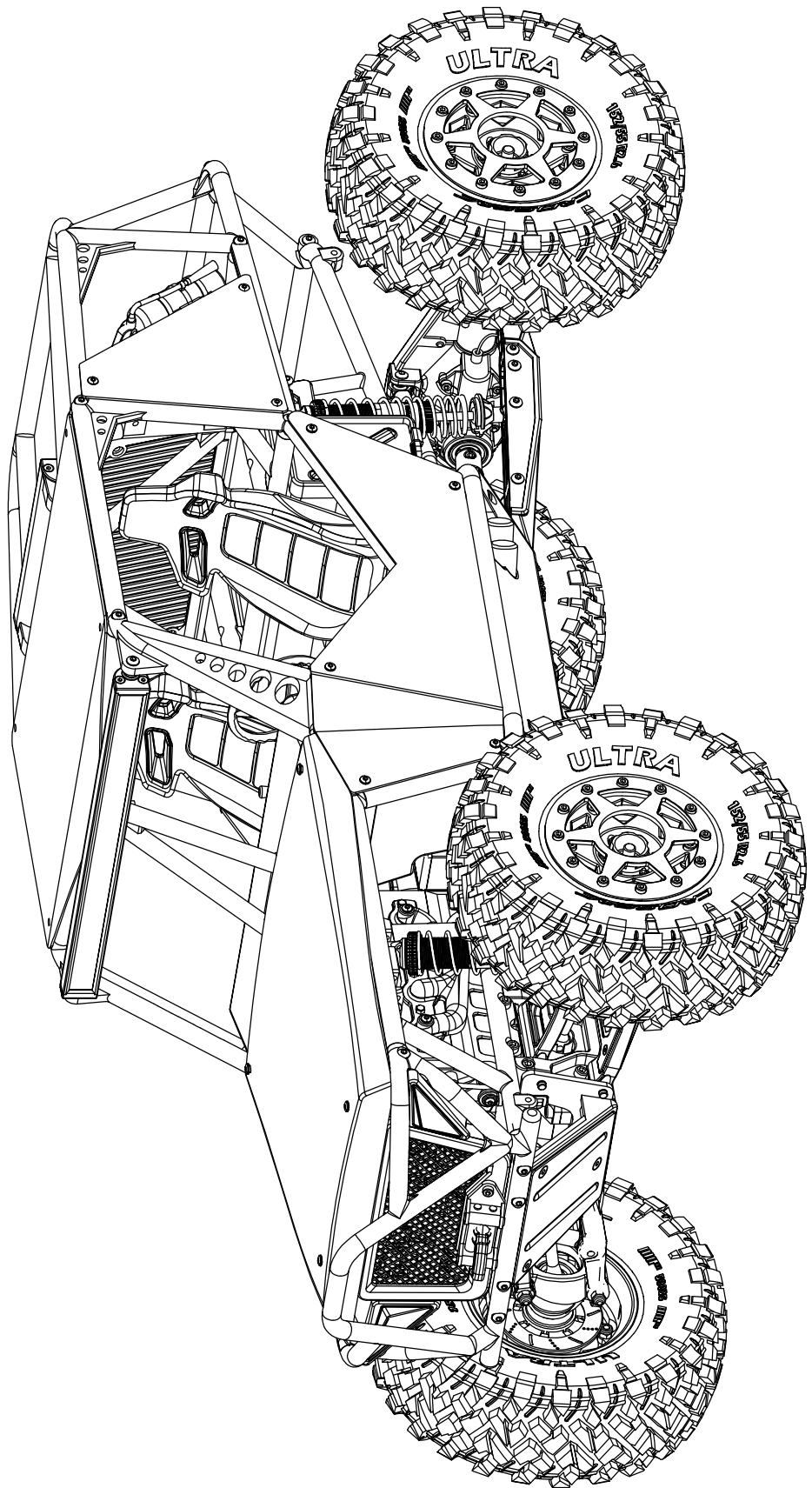

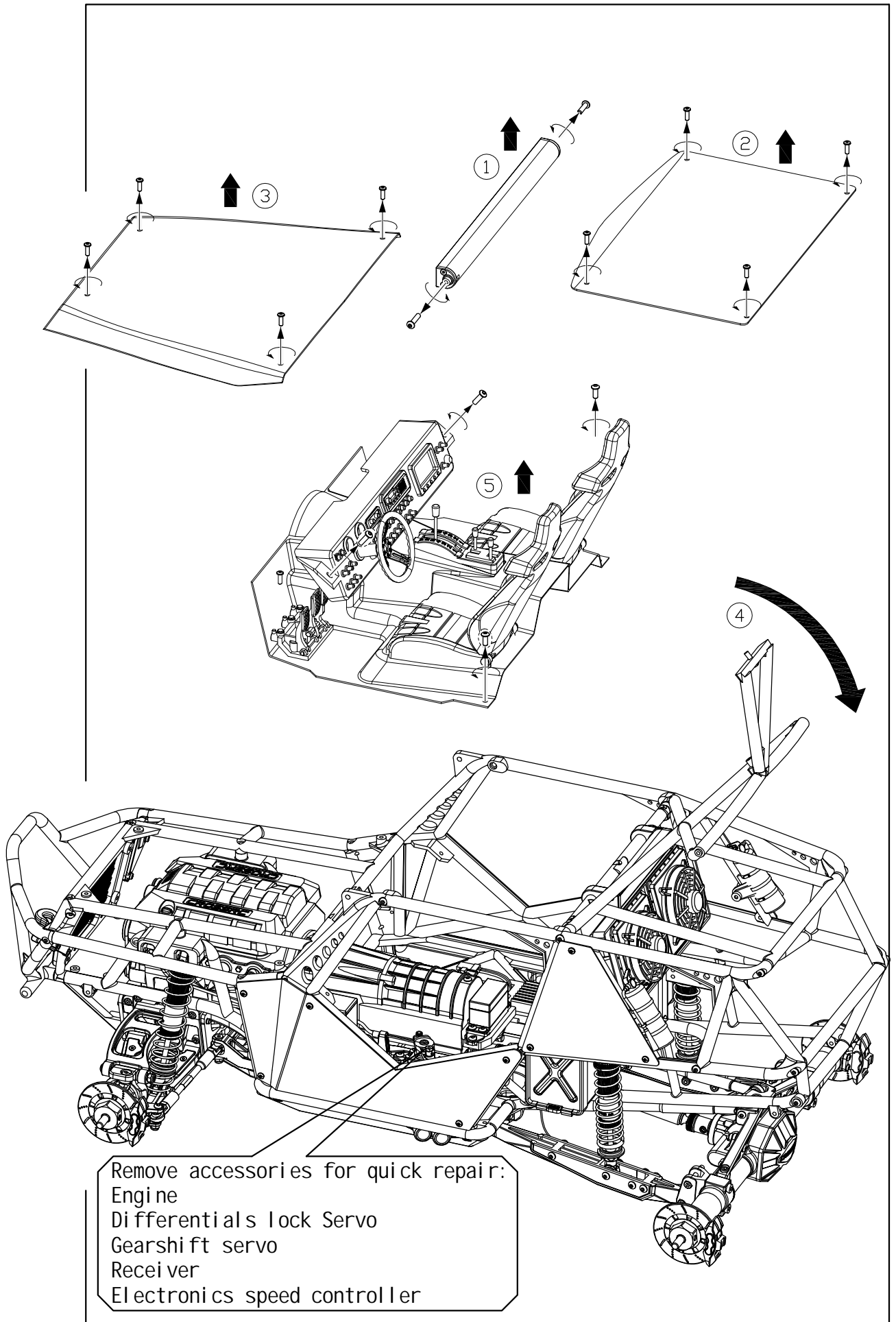

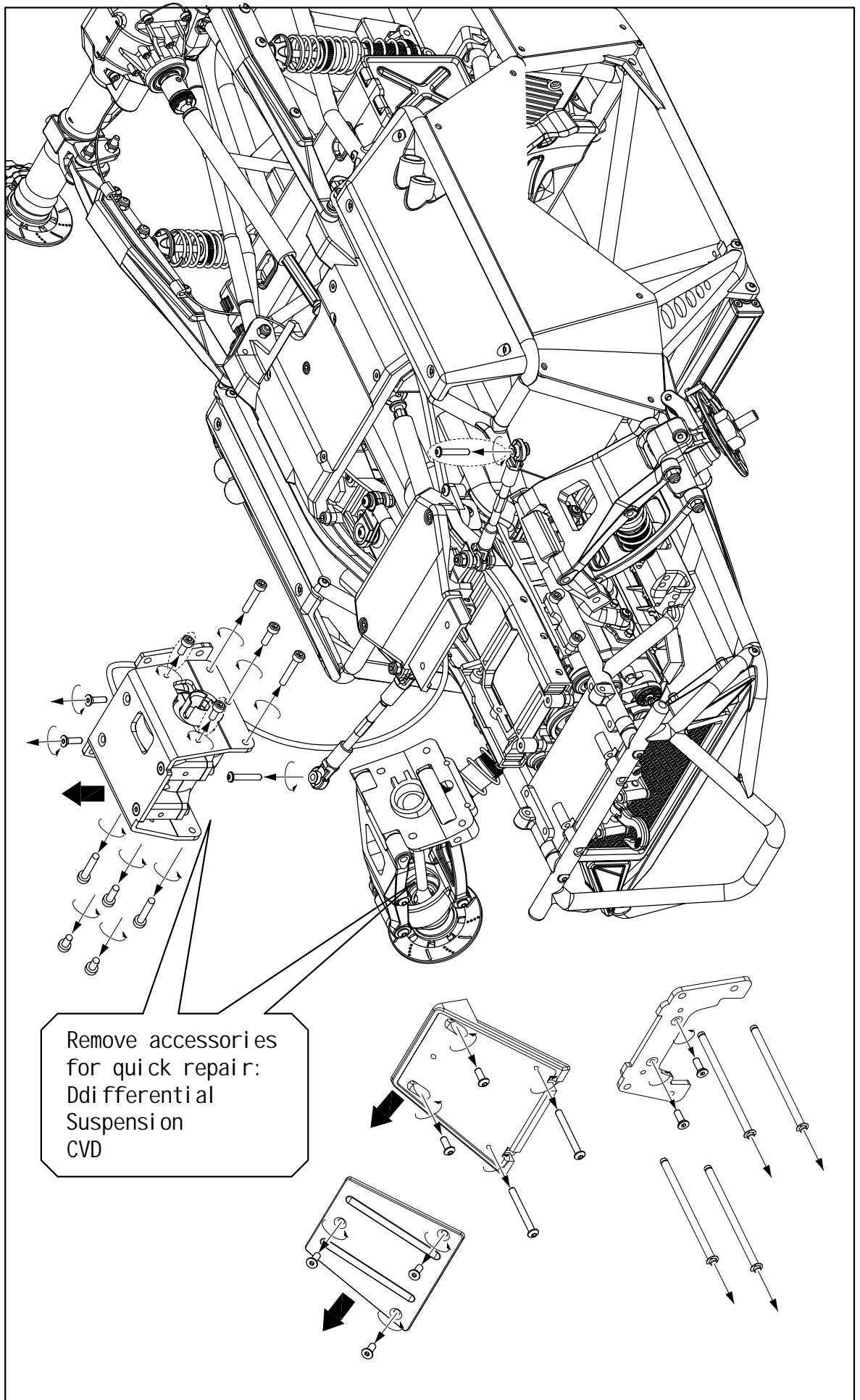

Remove accessories
for quick repair:
Differential
Suspension
CVD

Remove accessories for quick repair:
Rear differential

