

ADVENTURER

1/10 FULL-SIZE
4X4 PICKUP TRUCK

PG4A

PREMIUM
Quality
GUARANTEED

WWW.CROSS-RC.COM



CROSSRC

USER'S MANUAL

CAUTIONS



To prevent serious personal injury and/or property damage, operate all remotely controlled models in a responsible manner as outlined herein.

● Safety Precautions

- 1.1 Choose a right place to operate your RC model.
- 1.2 Do not operate your RC model on the street or highway. It can cause a serious damage or a serious accident.
- 1.3 Never operate your RC model near people or animals.
- 1.4 Do not operate RC model in public places like hospital and residential areas.
- 1.5 Never operate RC model indoors. There is a higher possibility of fire or damage.
- 1.6 Keep the parts out of reach of children, small parts can cause choking and vinyl bags can suffocate.
- 1.7 Do not use with children younger than 14 years.

● Inspect your RC model before operation

- 2.1 Make sure that all screws and nuts are properly tightened. It is also a good idea to use removable thread lock wherever metal screws go into metal, especially for engine mounts and the engine pilot shaft.
- 2.2 Always use fresh batteries for your transmitter and for your receiver to avoid losing control of the model.
- 2.3 Always test the brakes and throttle before starting your engine to avoid losing control of the model.
- 2.4 Always turn on the transmitter first, and then turn on the receiver.

● After operation of your RC model

- 3.1 Turn off receiver first, then turn off transmitter, this will prevent runaways.
- 3.2 Be careful when handling batteries, they will be hot after running.
- 3.3 Replace any batteries that have been dented or have frayed wires, short circuits can cause fire.

TOOLS

(Not included)

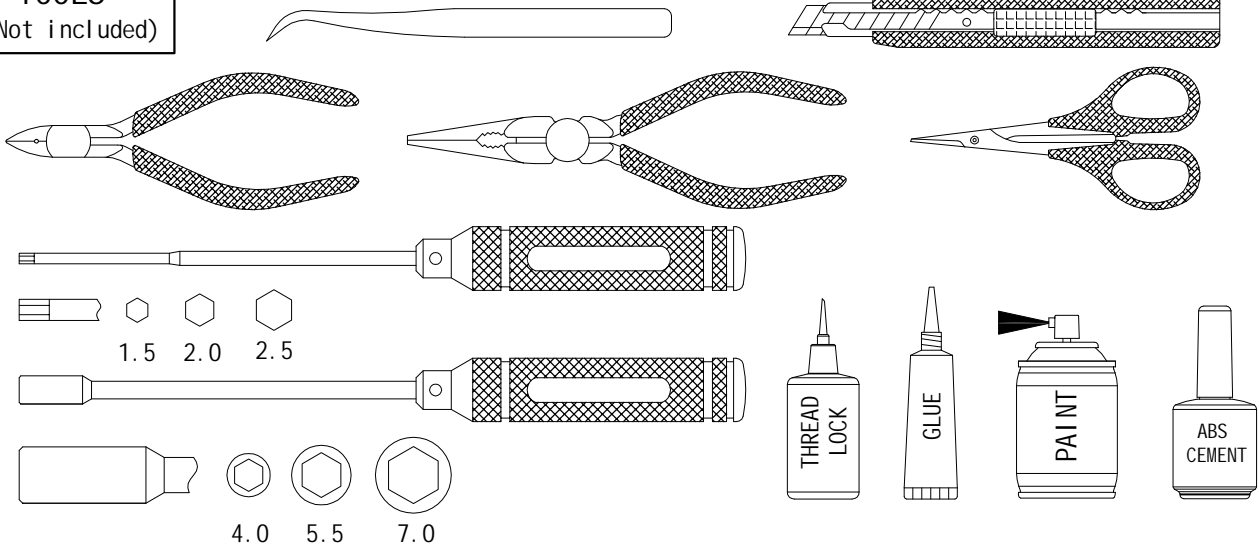





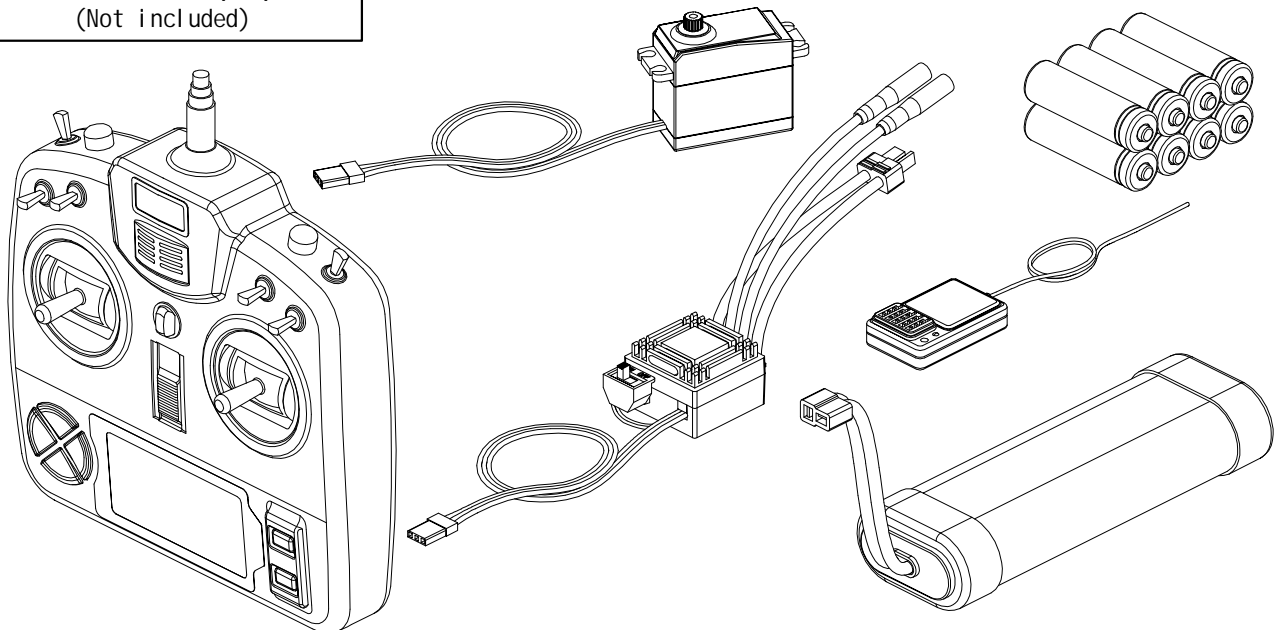

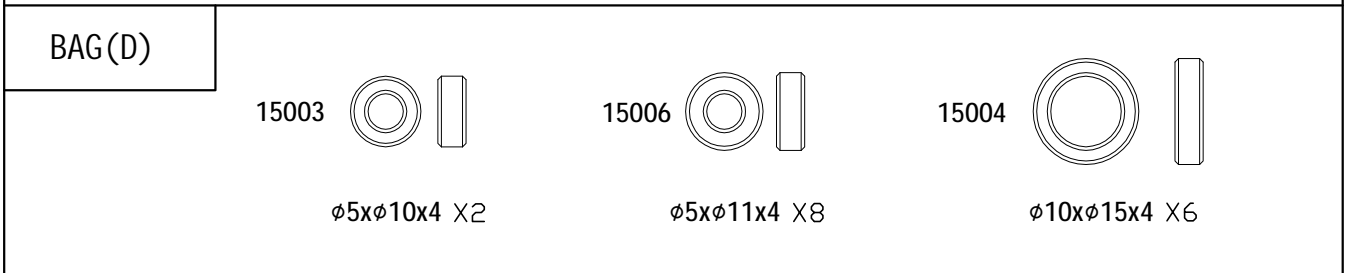
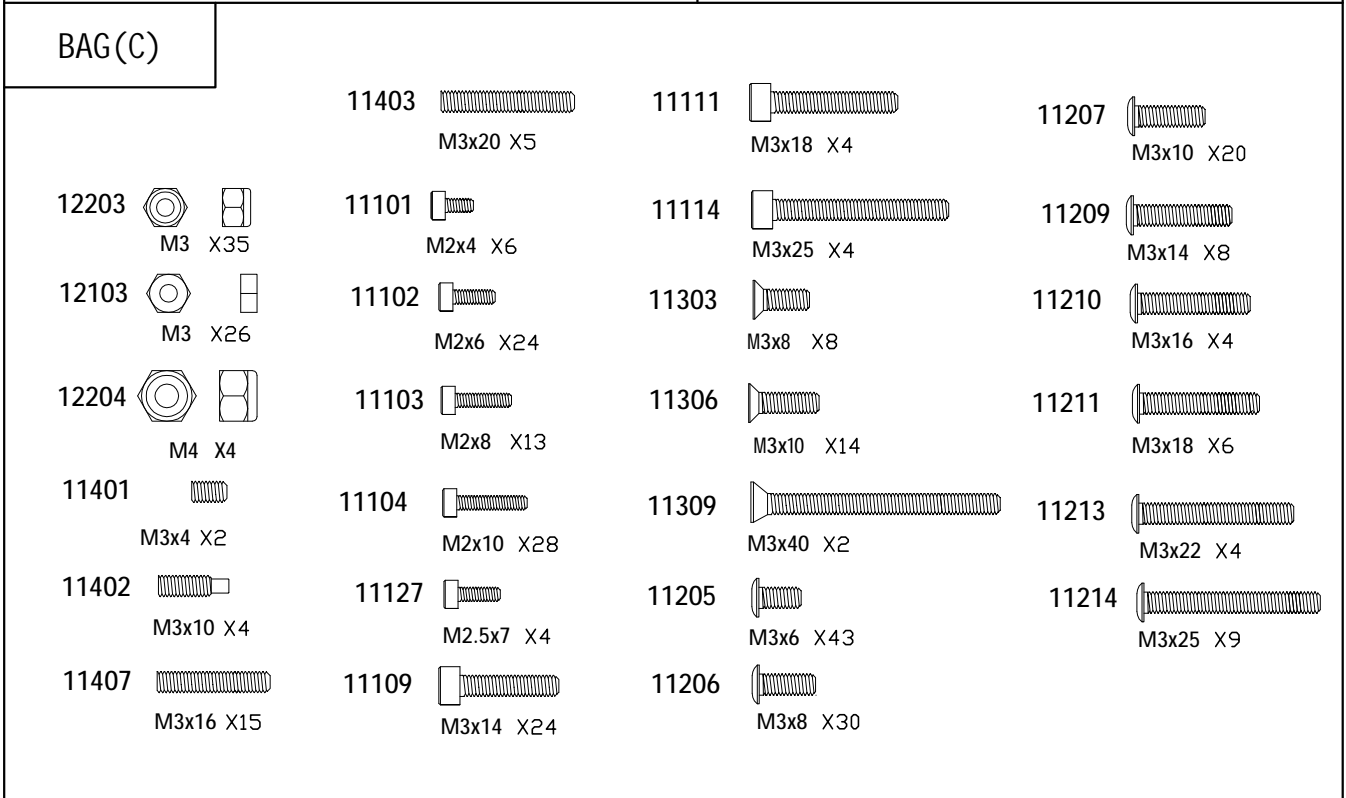
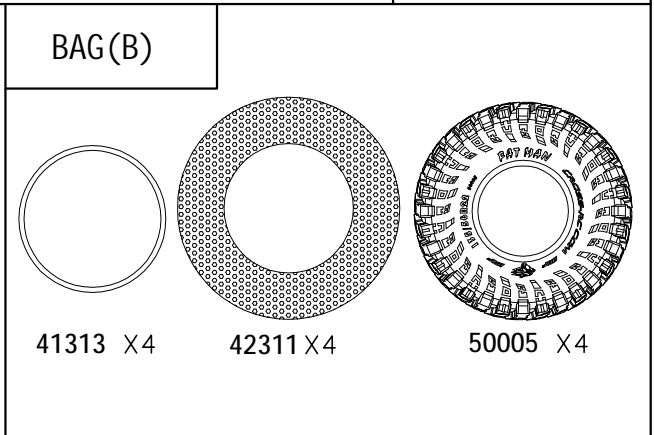
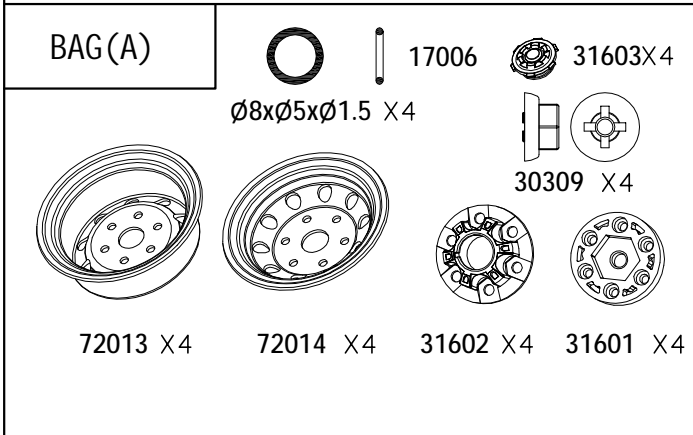
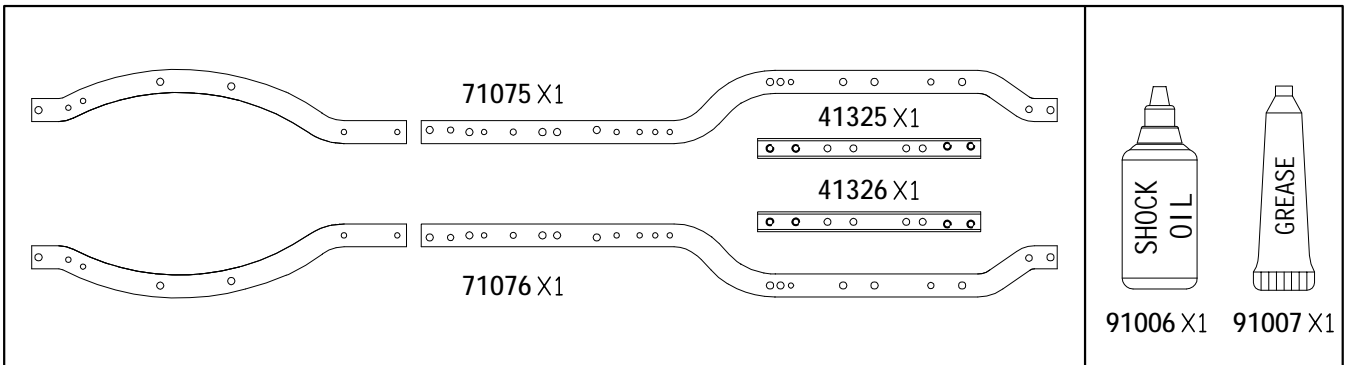

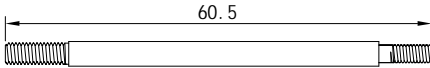
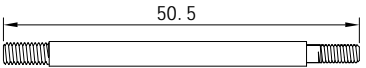













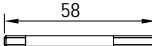



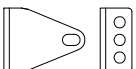
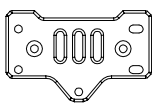



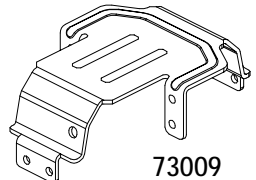
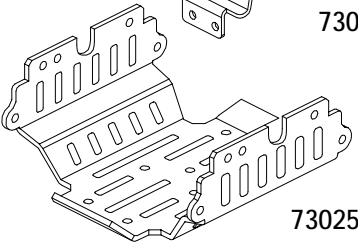

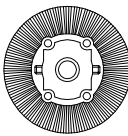
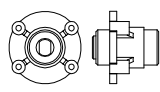
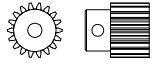
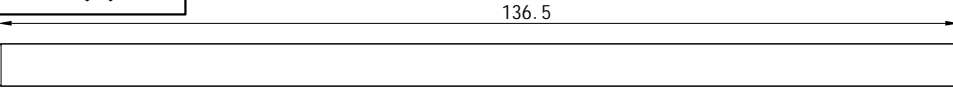

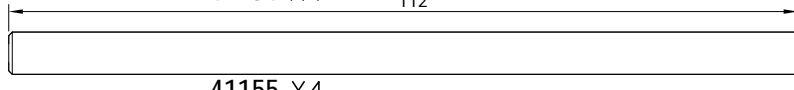

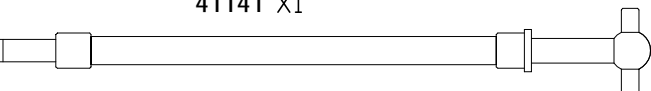

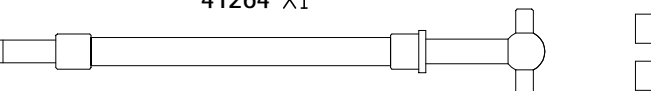

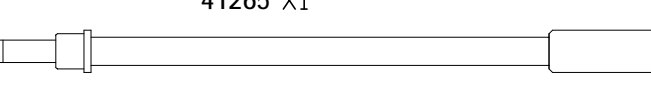
Electronic equipment

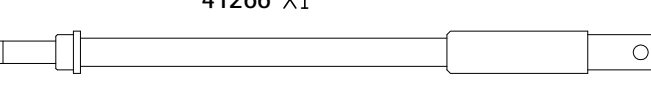
(Not included)

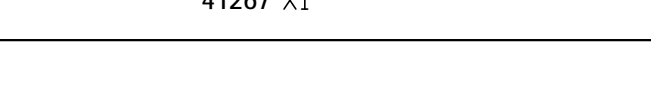

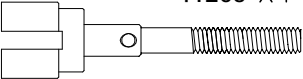

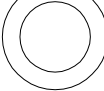
BAG (E)	
 41131 X2	 41132 X2
50017  $\varnothing 8 \times \varnothing 3.5 \times 9$ X2	50021  $\varnothing 7.5 \times \varnothing 3.5 \times \varnothing 2$ X8
14105  $\varnothing 5 \times \varnothing 2.5 \times 0.4$ X8	41328  X2
50018  $\varnothing 8 \times \varnothing 3.5 \times 4$ X2	50020  $\varnothing 9 \times \varnothing 6 \times \varnothing 1.5$ X4
12205  M2.5 X4	41323  X2
BAG (F)	
12203  M3 X5	41144  41145  41324 X2  41104  41150 
11303  M3x8 X7	12303  M3 X1
14102  $\varnothing 3 \times \varnothing 7 \times 0.5$ X8	71024  44022 X2 
11206  M3x8 X4	11207  M3x10 X1
11211  M3x18 X1	73009  73025 
BAG (G)	
30202(12T) X2 	30201(36T) X2 
30205 X2 	41304(18T) X1 
BAG (H)	
 41154 X4	 41127 X2
 41155 X4	 41126 X8
41141 X1 	41113 X1 
41264 X1 	41209 X6 
41265 X1 	41237 X2 
41266 X1 	13003  $\varnothing 2.5 \times \varnothing 6 \times 0.4$ X2
41267 X1 	41205 X4 
	41230 X2 
	41332 X1 
	72003  $\varnothing 5 \times \varnothing 8 \times 0.5$ X2
	72008  $\varnothing 13.5 \times \varnothing 10 \times 0.2$ X4

BAG(I)

23401 X1 23402 X1 23407 X1 23408 X1 13102 X10

21205 X2 23405 X1 23406 X1 21200 X4

22501 X1

BAG(J)

95021 X1 95020 X1

91004 X2 71027 X1 71028 X2 21908 X2

73014 X1 73013 X1 73015 X2

73017 X1 73018 X1 73019 X1

73020 X1 73021 X1 73022 X1

73027 X1 73028 X1 73030 X1 73031 X1

BAG(K)

14102 $\phi 3 \times \phi 7 \times 0.5 \times 2$ 72007 $\phi 5 \times \phi 8 \times 0.3 \times 2$ 72003 $\phi 5 \times \phi 8 \times 0.5 \times 2$

41260 X1 41261 X1 41262 X1 41263 X1 41129 X1 41307 X1

13002 $\phi 3.8 \times \phi 9.2 \times 0.6 \times 10$ 13003 $\phi 2.5 \times \phi 6 \times 0.4 \times 2$

11401 M3x4 X1 15003 $\phi 5 \times \phi 10 \times 4 \times 12$

11106 M3x8 X2 11102 M2x6 X2 11207 M3x10 X4

31403 31402 31401 31404 31405

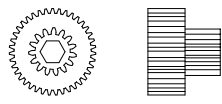

25201 X1

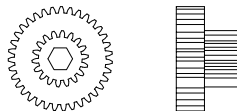

25202 X1

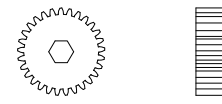

25203 X1



25204 X1



25205 X1

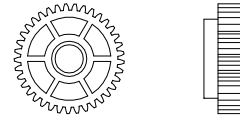

25206 X1

BAG(L)

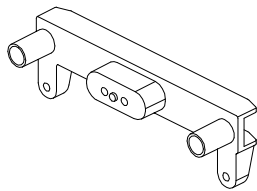

22401 X1

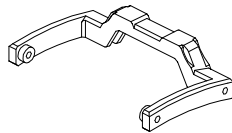

22402 X1

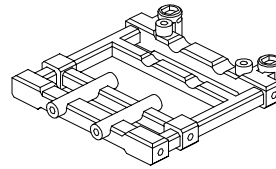

22403 X1

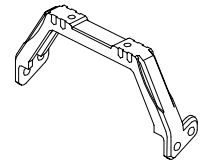

22405 X1

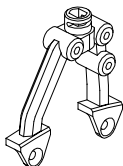

25301 X1

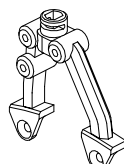

25302 X1

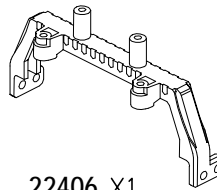

22406 X1

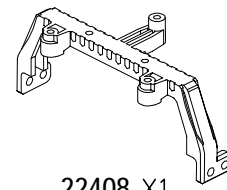

22408 X1

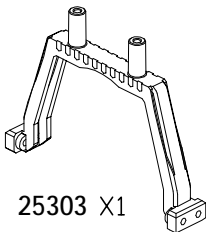

25303 X1



25305 X2

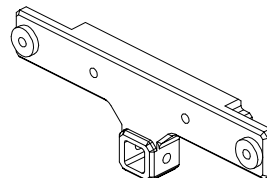

44035 X1

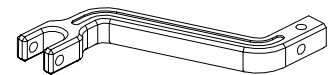

44036 X1

BAG(M)



73010 X1



73011 X1

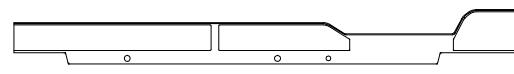

27506 X1

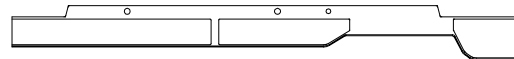

27507 X1

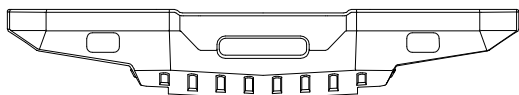

25401 X1

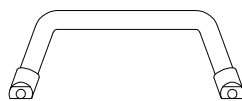

25402 X1



94007 X2



22605 X1

11127

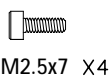

M2.5x7 X4

11901

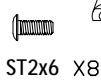

ST2x6 X8

12105

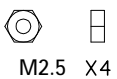

M2.5 X4



30402 X2



30411 X2



30113 X2



41334 X2



22607 X1

BAG(N)

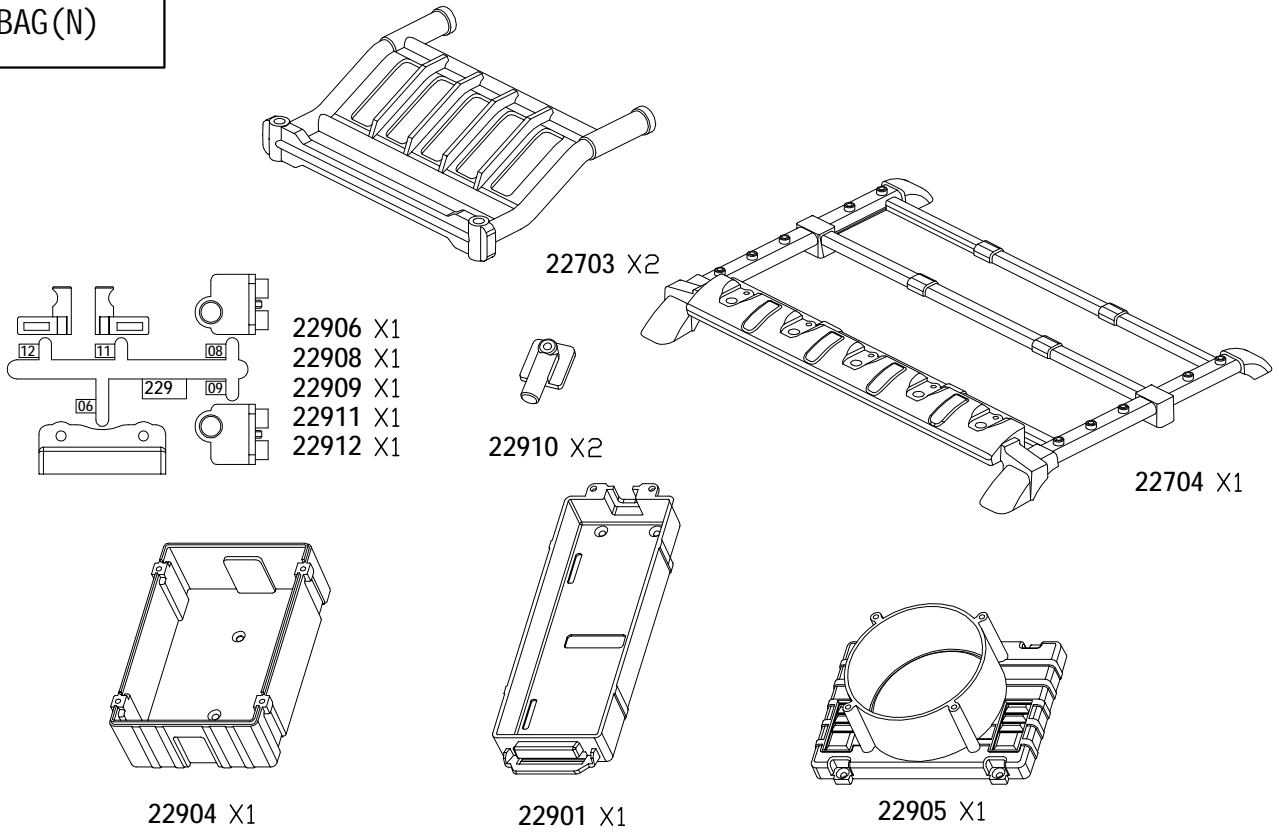

BAG(O)

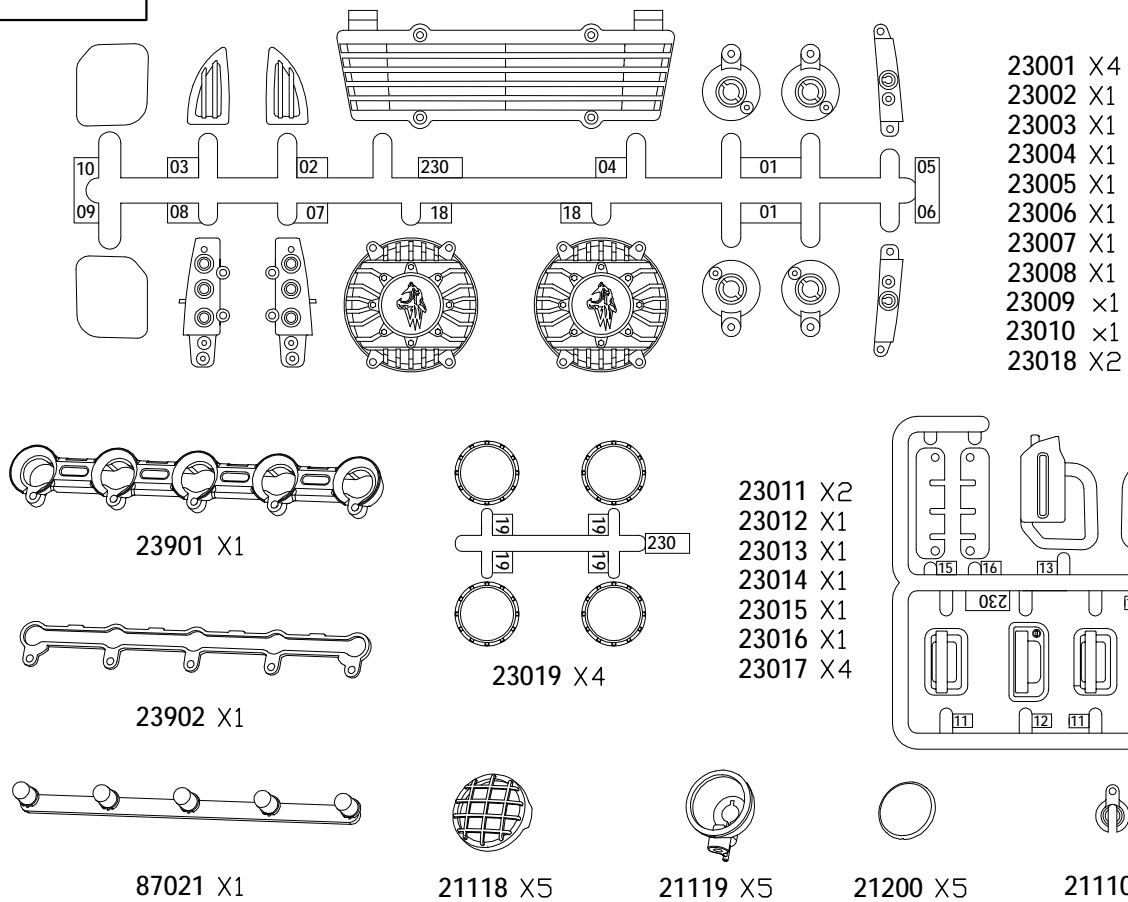

BAG(P)

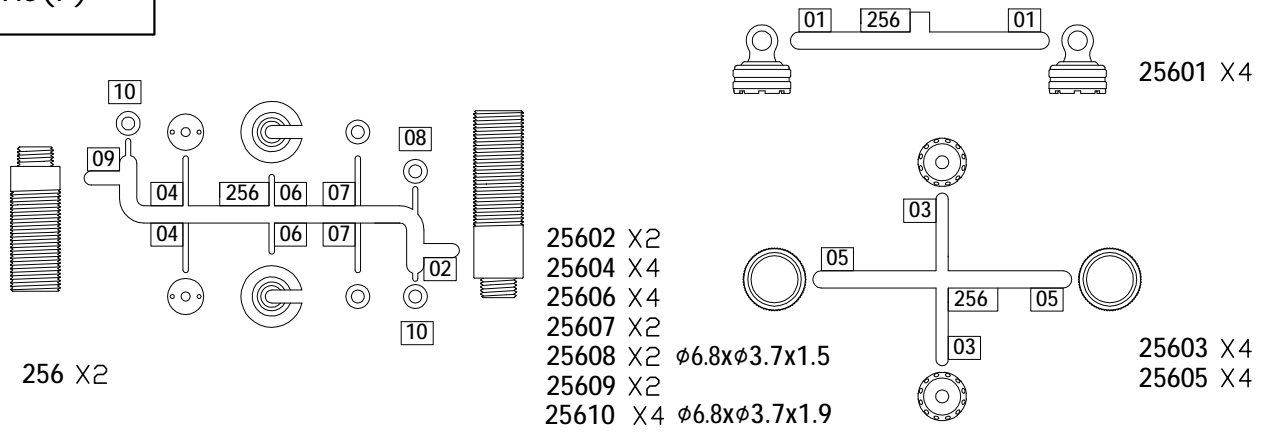

BAG(Q)

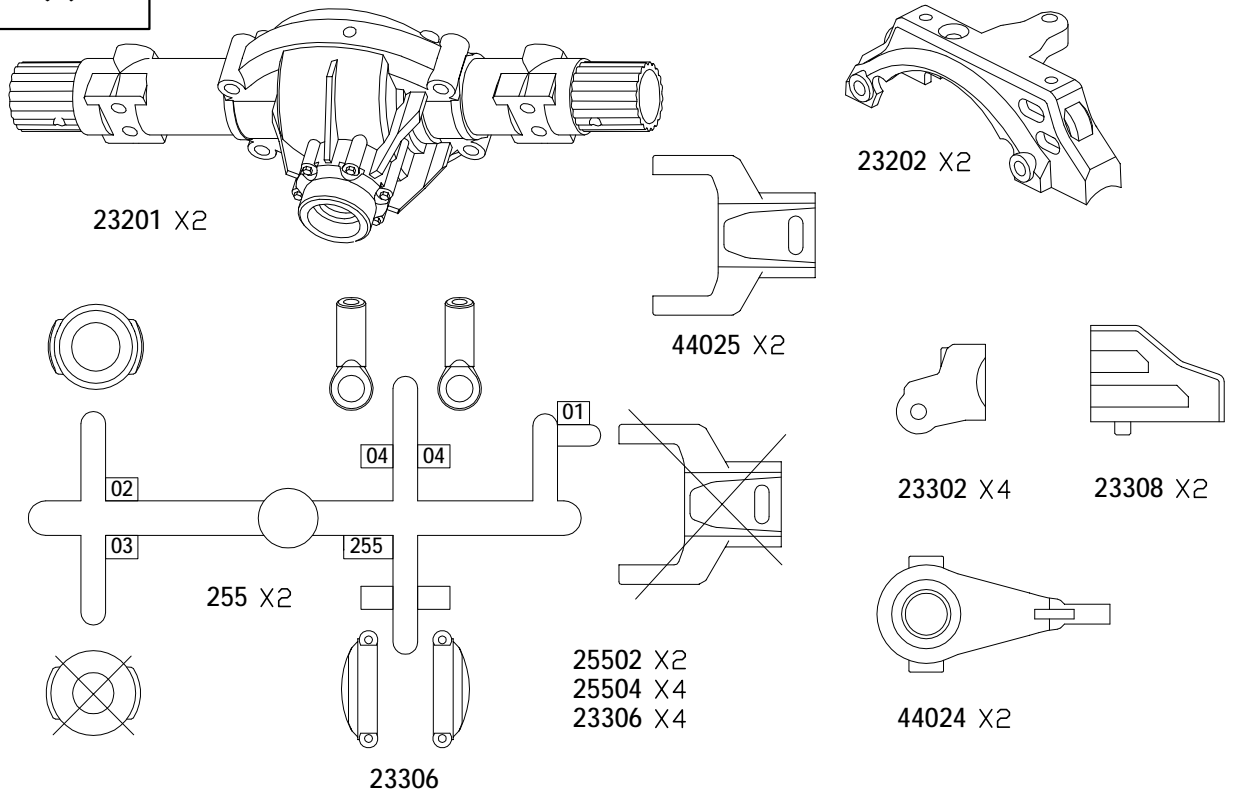

BAG(R)

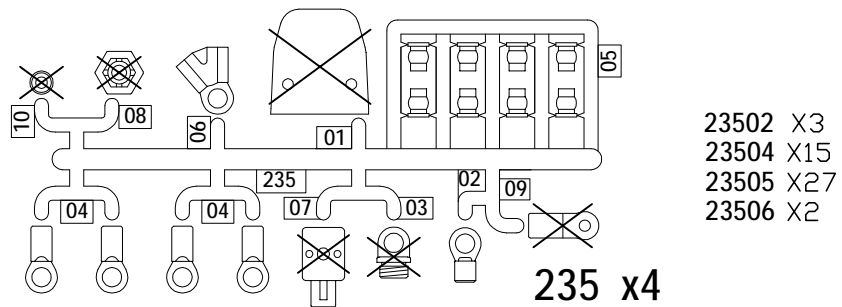

BAG(S)

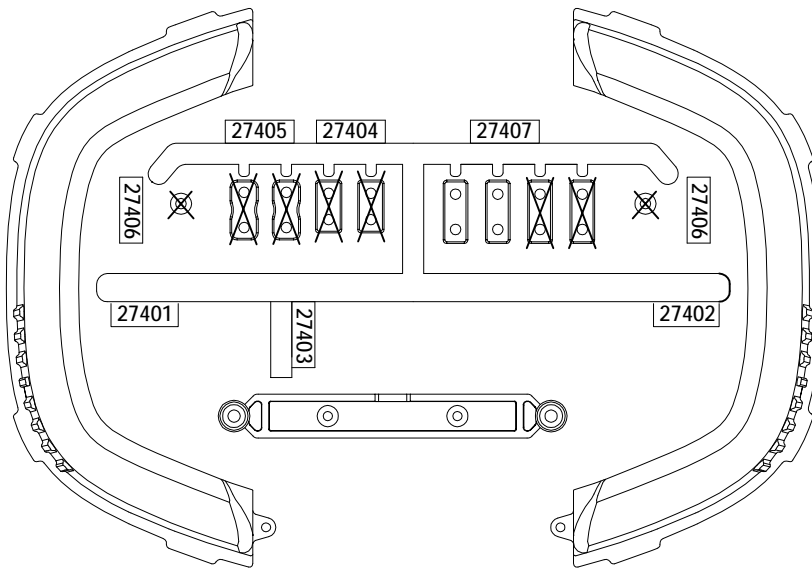

- 27408 X1
- 27409 X1
- 27403 X1
- 27407 X2

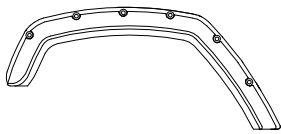

23805 X1

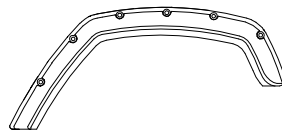

23806 X1

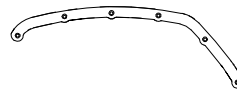

23809 X1

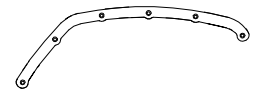

23810 X1

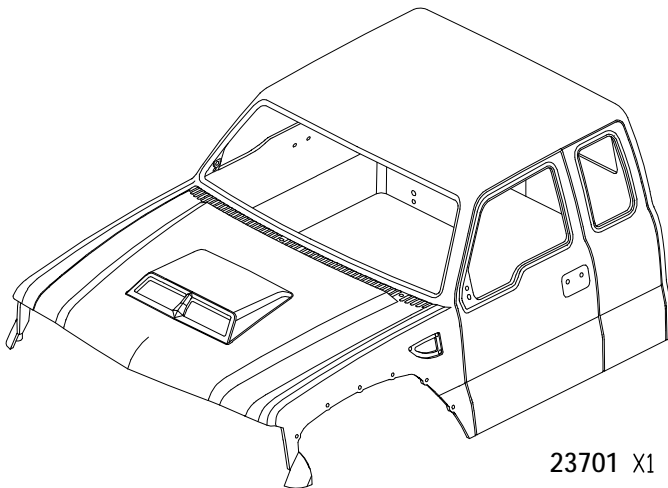



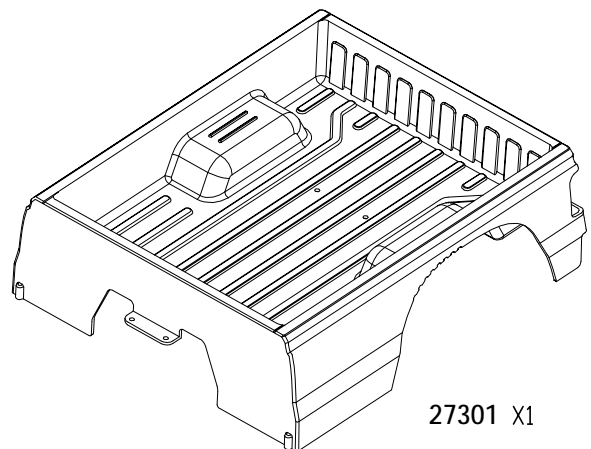

23701 X1

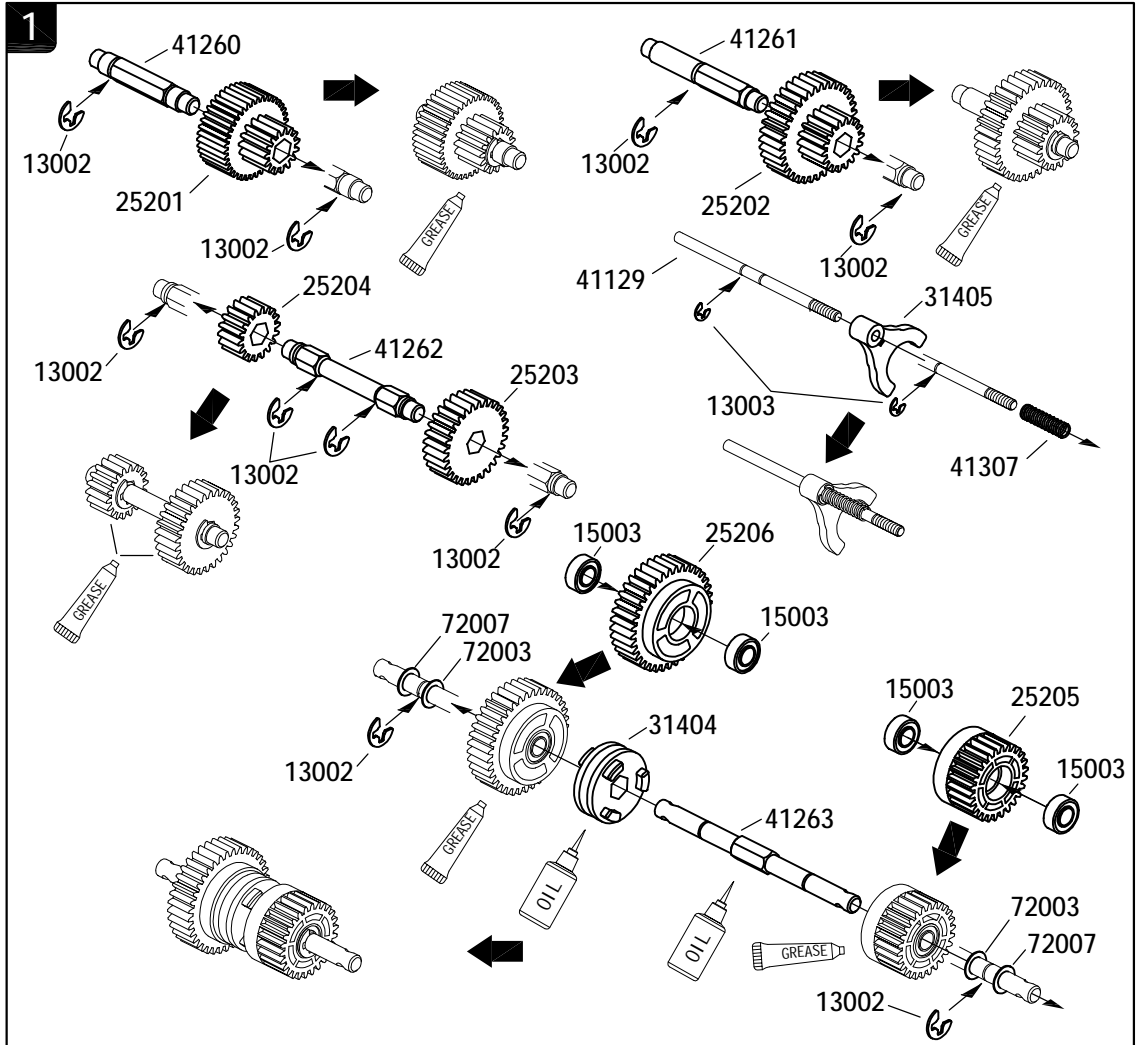

27301 X1



- 13002  $\phi 3.8 \times \phi 9.2 \times 0.6 \times 10$
- 13003  $\phi 2.5 \times \phi 6 \times 0.4 \times 2$
- 72007  $\phi 5 \times \phi 8 \times 0.3 \times 2$
- 15003  $\phi 5 \times \phi 10 \times 4 \times 4$
- 72003  $\phi 5 \times \phi 8 \times 0.5 \times 2$

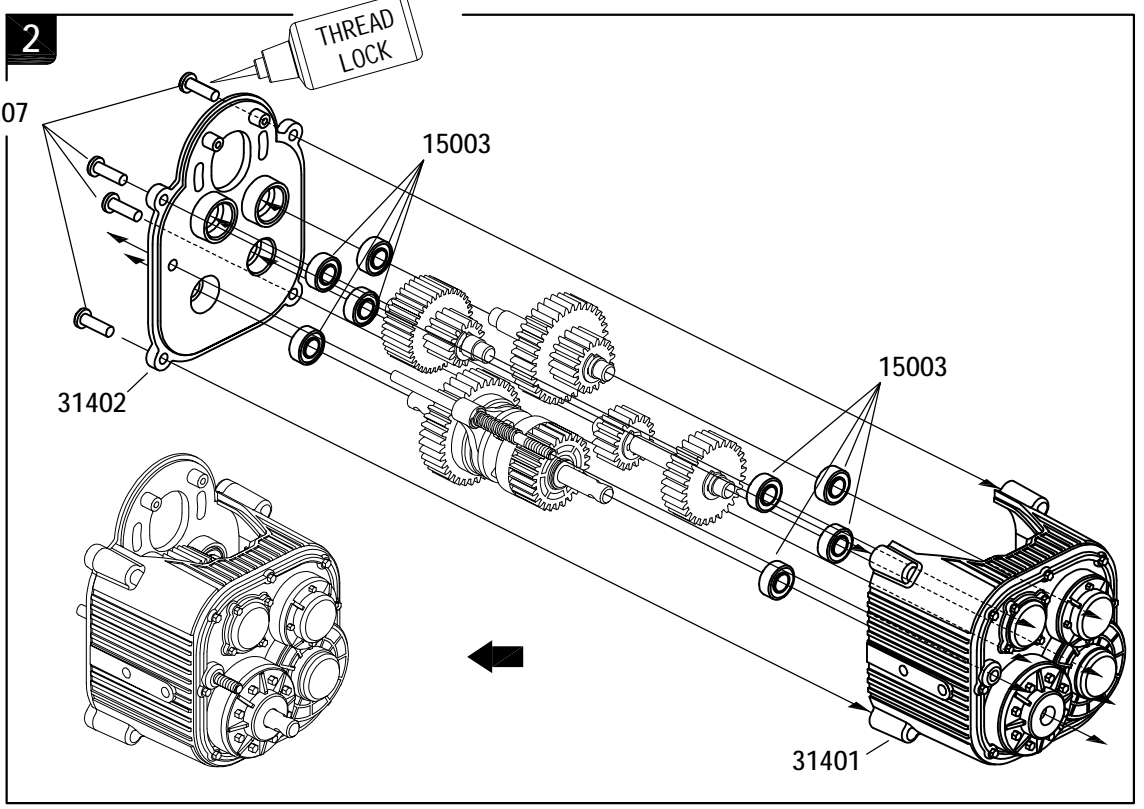

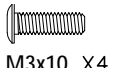

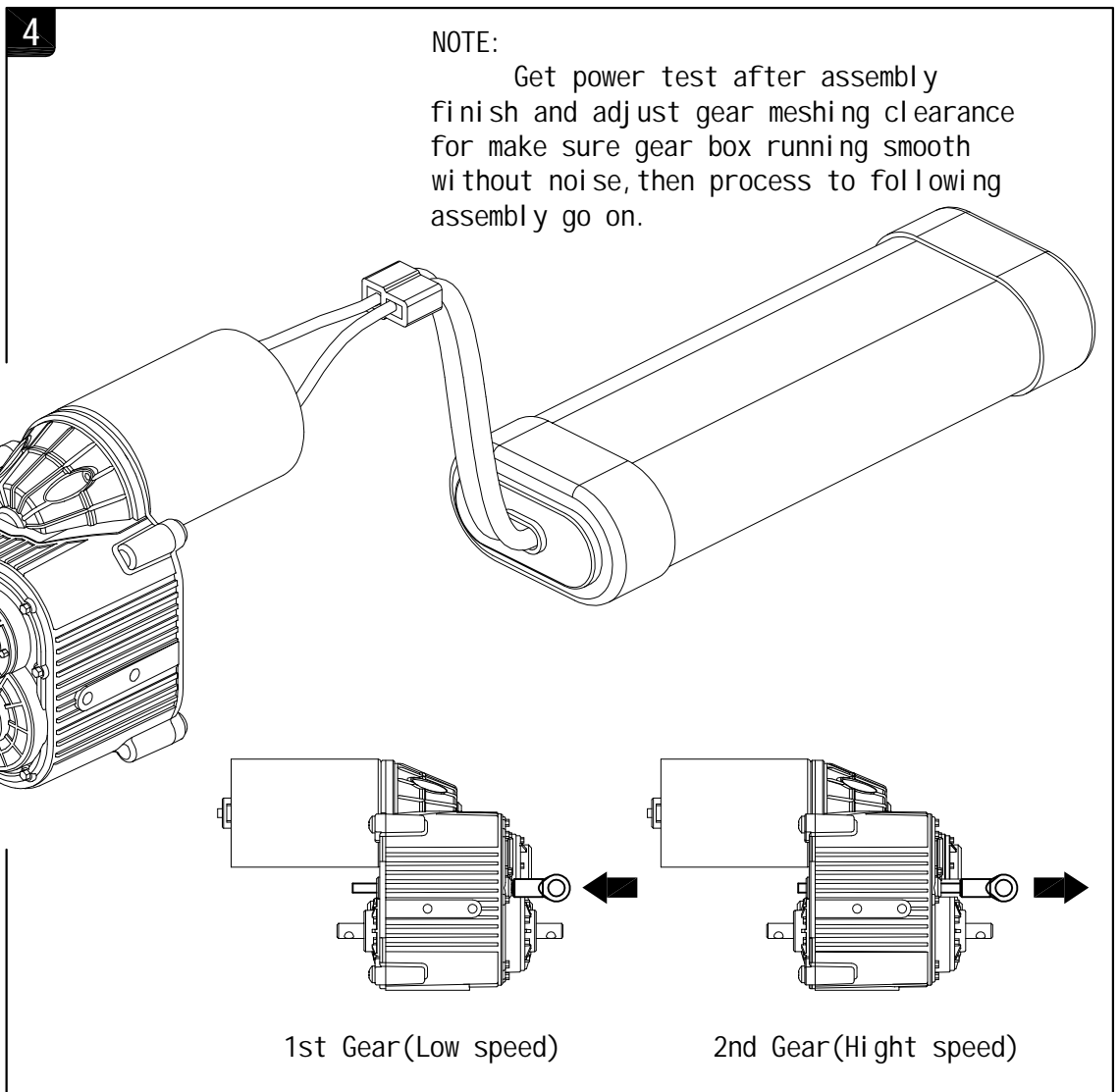
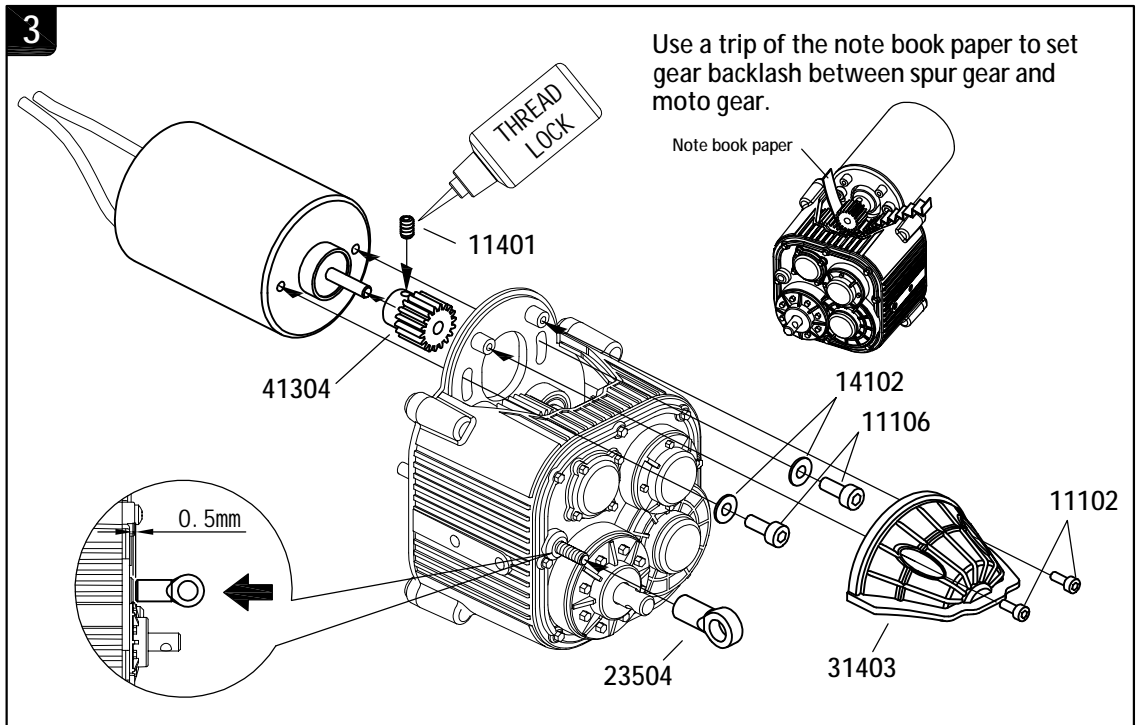

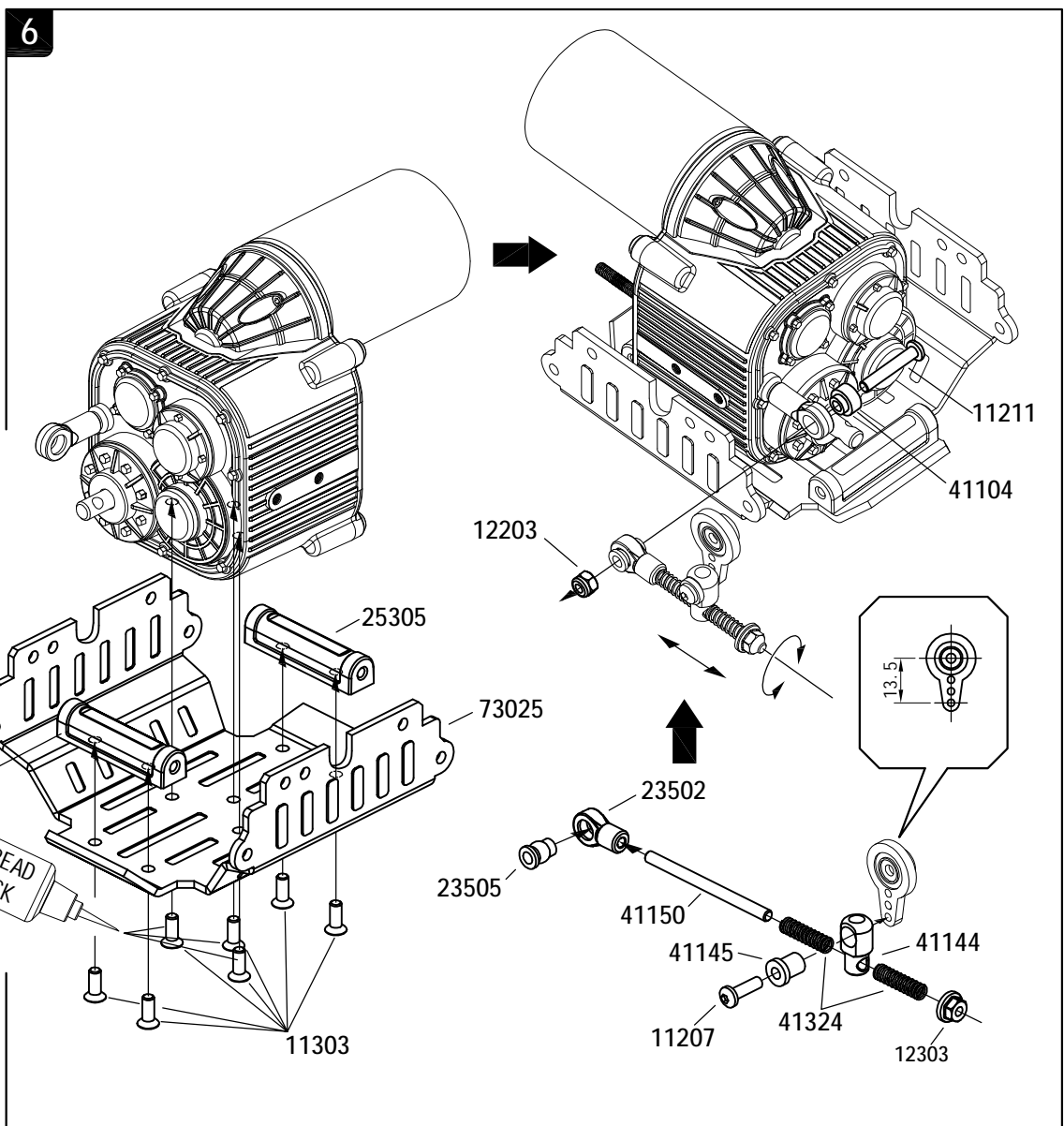
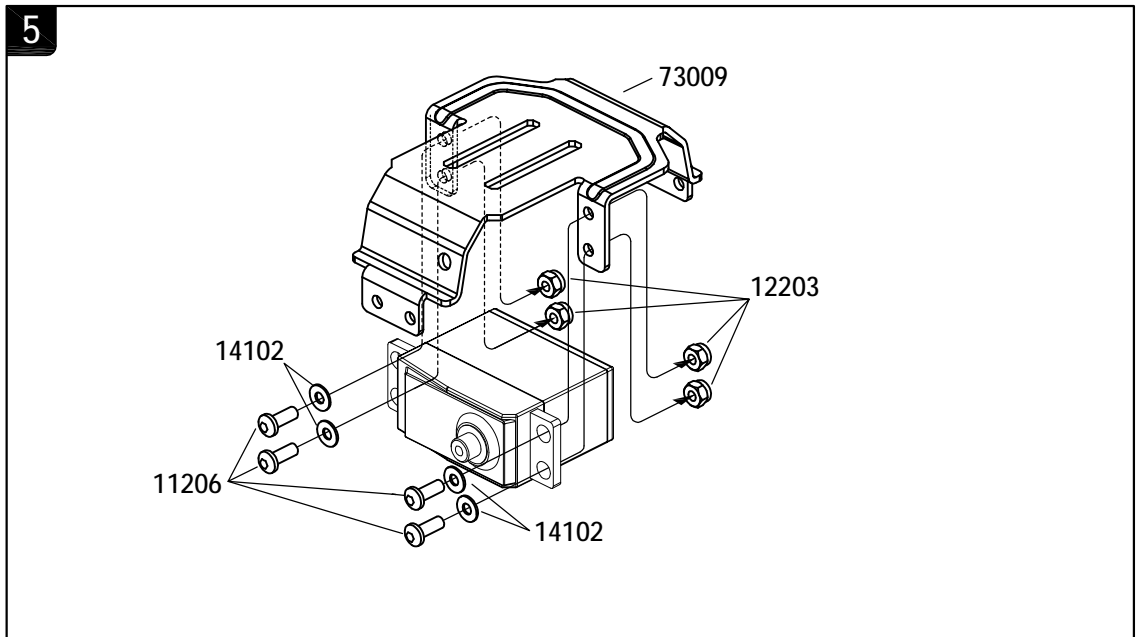
- 15003  $\phi 5 \times \phi 10 \times 4 \times 8$
- 11207  M3x10 X4

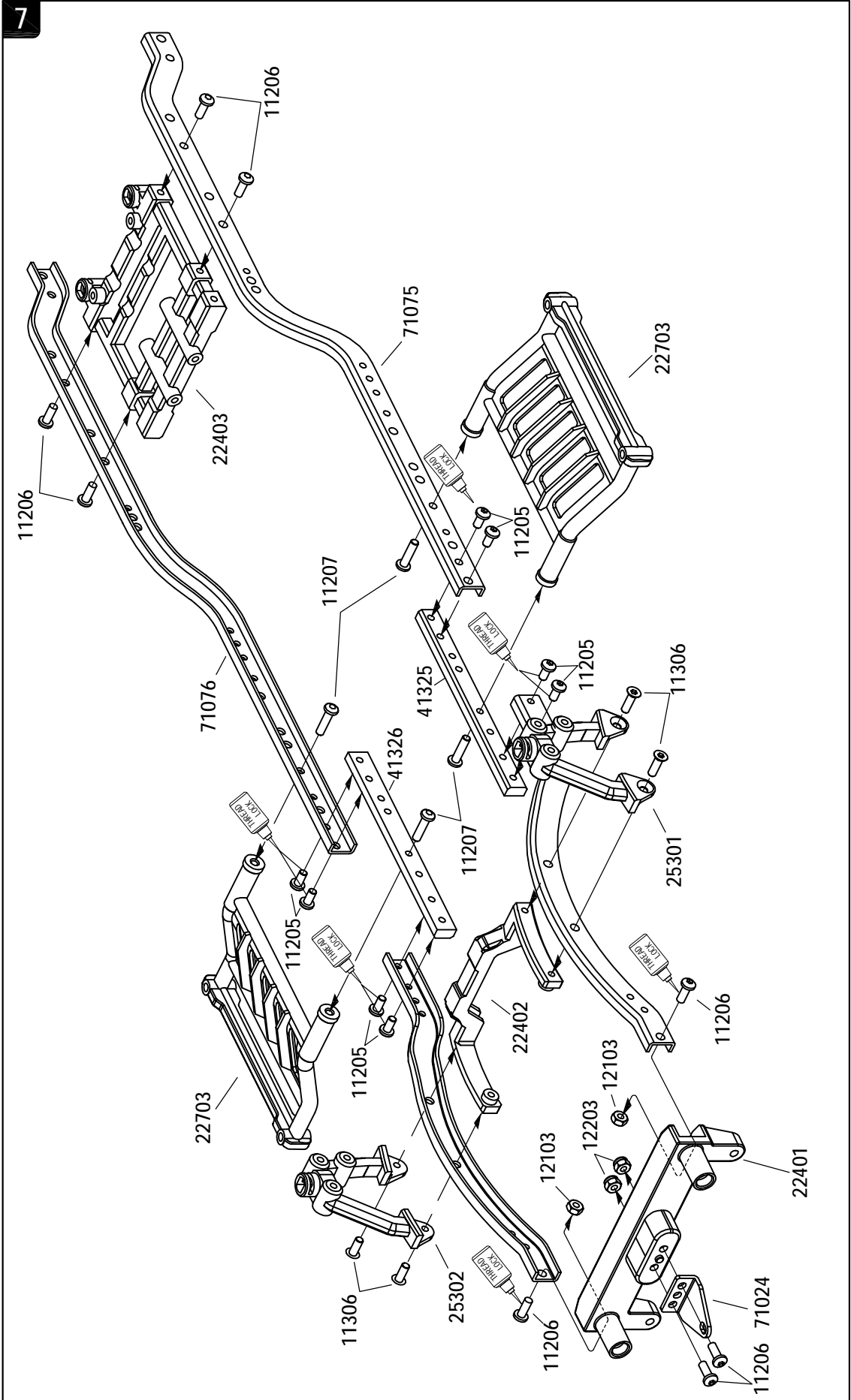





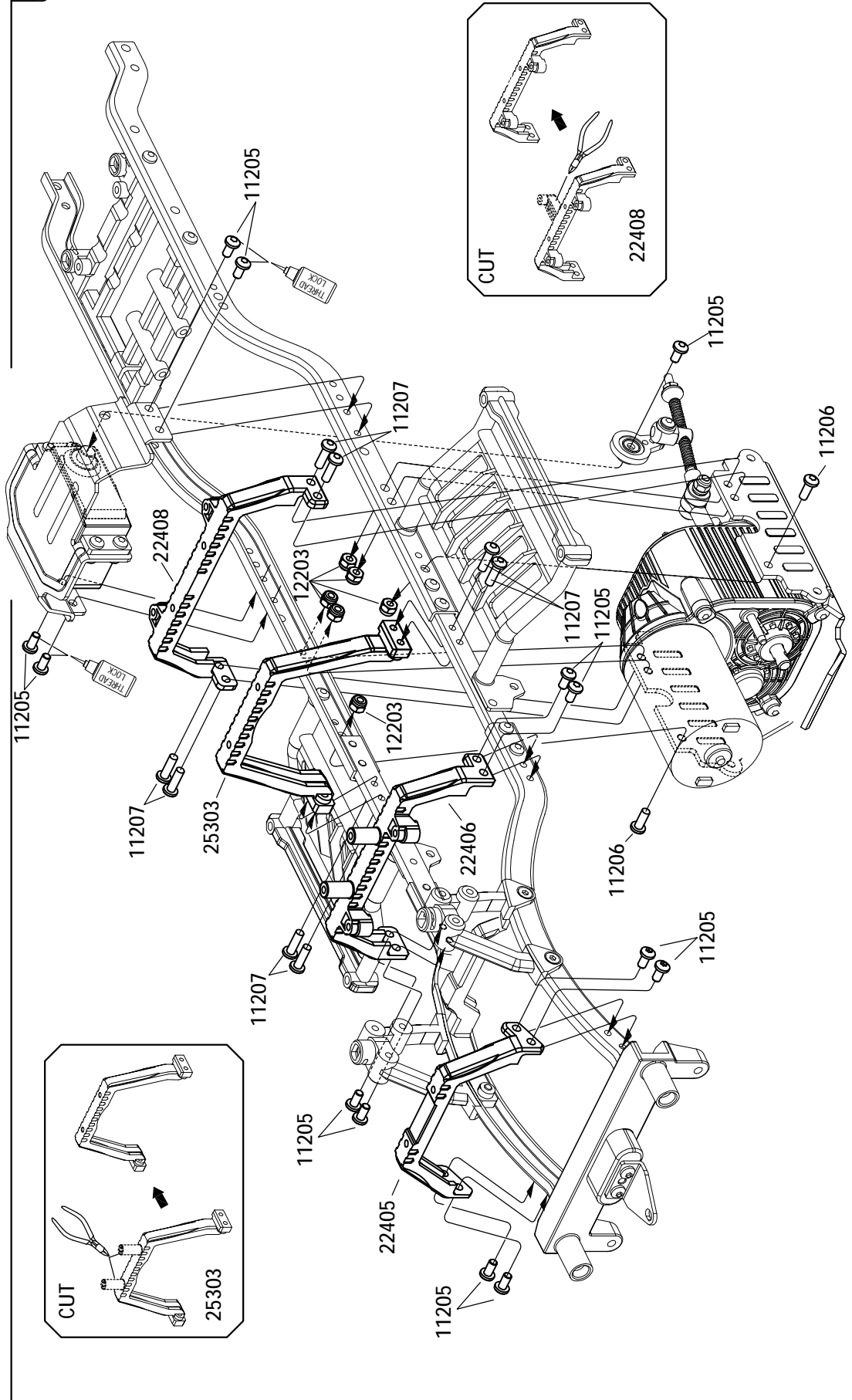

8

- 11205  M3x6 X13
- 11206  M3x8 X2
- 11207  M3x10 X8
- 12203  M3 X6



9

11127  M2.5x7 X4

12105  M2.5 X4

11206  M3x8 X2

11901  ST2x6 X8

25402

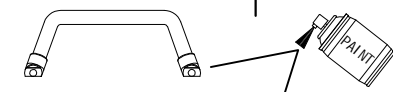

25401

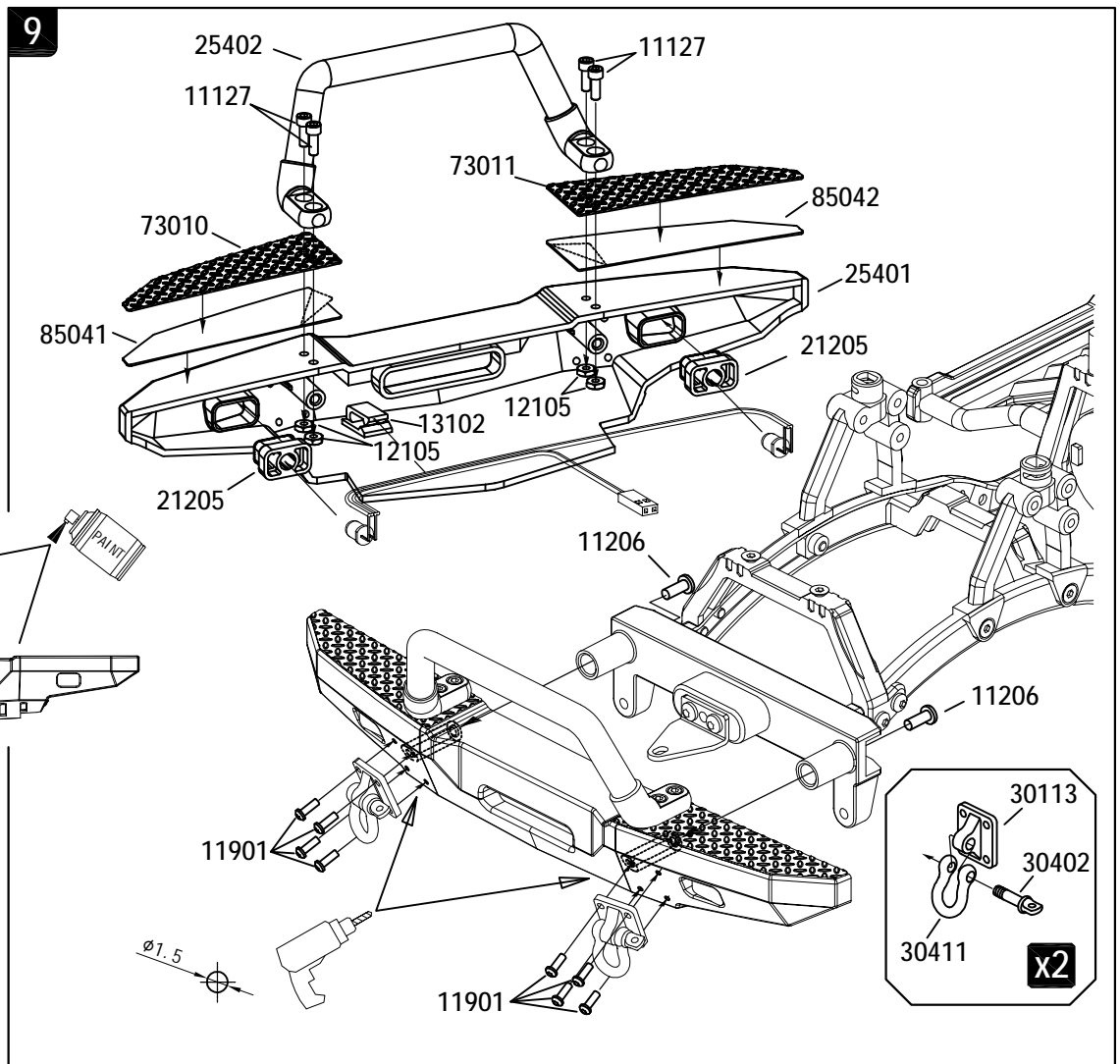
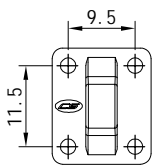
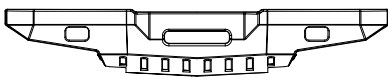



10

11309  M3x40 X2



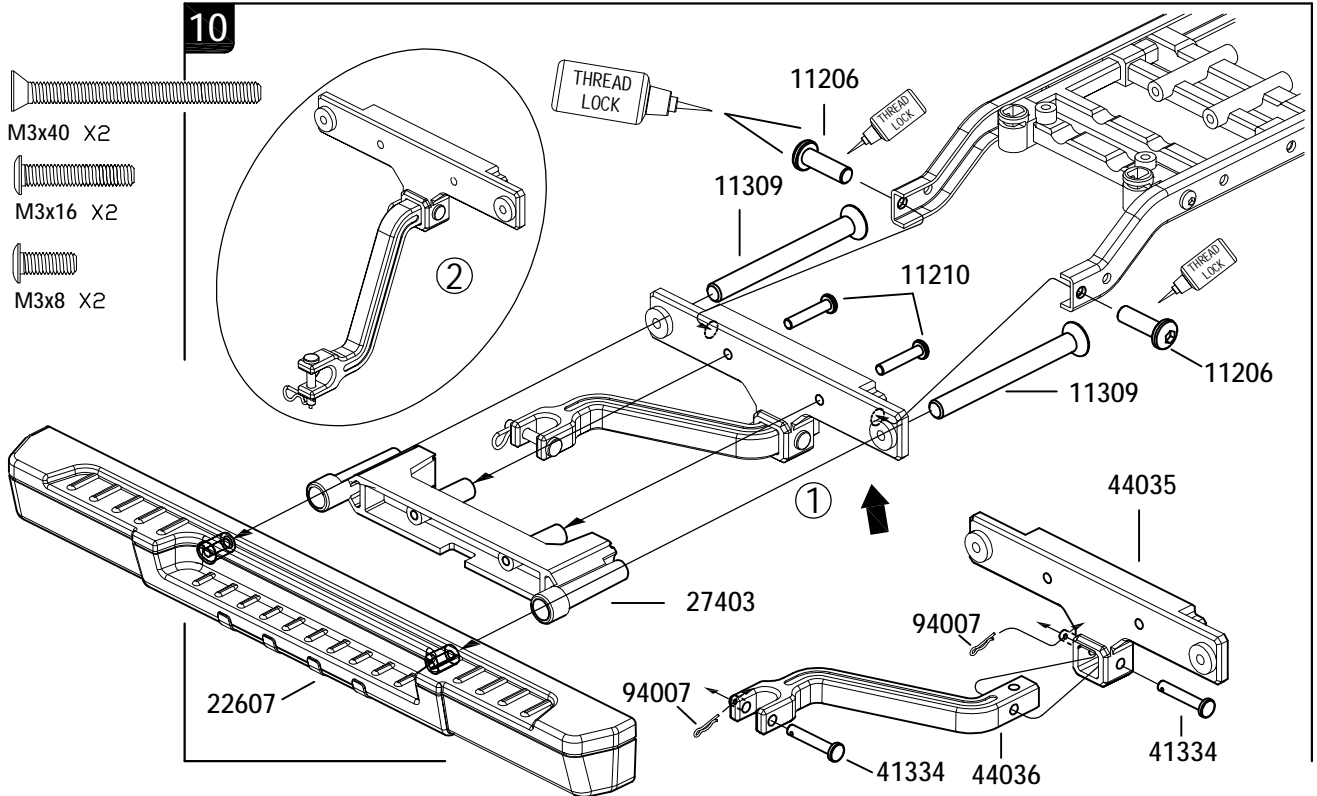

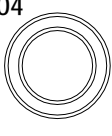
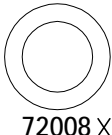

11210  M3x16 X2

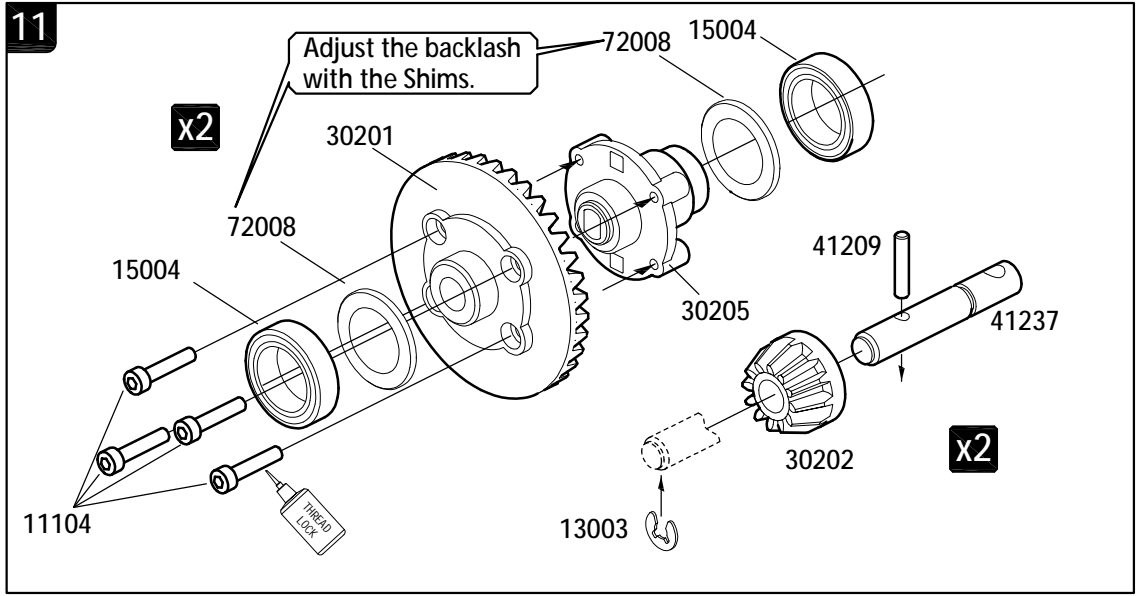
11206  M3x8 X2



- 11104  M2x10 X8
- 13003  $\phi 2.5 \times \phi 6 \times 0.4$ X2
- 15004  $\phi 10 \times \phi 15 \times 4$ X4
- 72008  X4



- 11103  M2x8 X8
- 11104  M2x10 X8
- 15006  $\phi 5 \times \phi 11 \times 4$ X4
- 11401  M3x4 X2
- 13002  $\phi 3.8 \times \phi 9.2 \times 0.6$ X2
- 72003  $\phi 5 \times \phi 8 \times 0.5$ X2

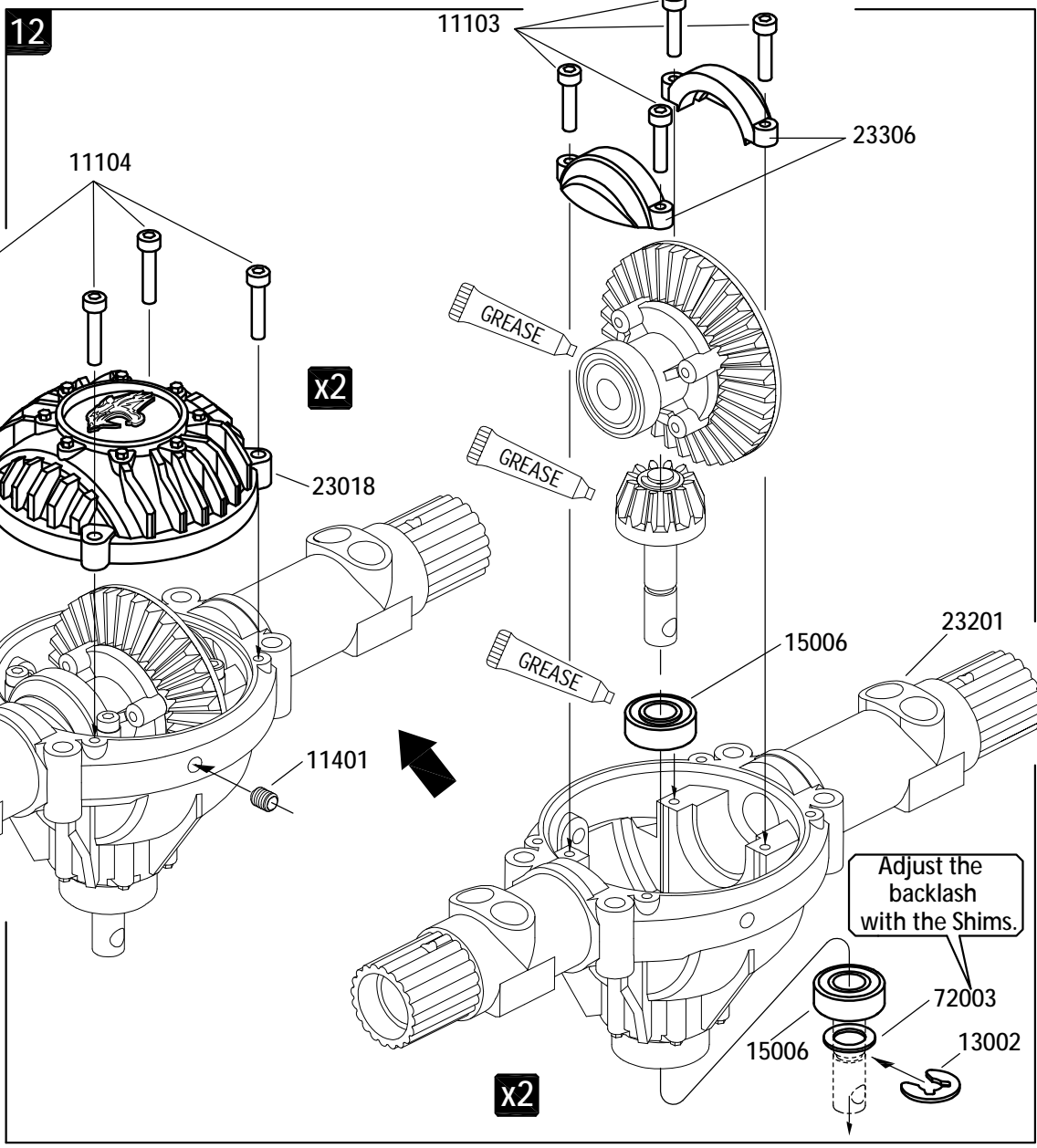

13

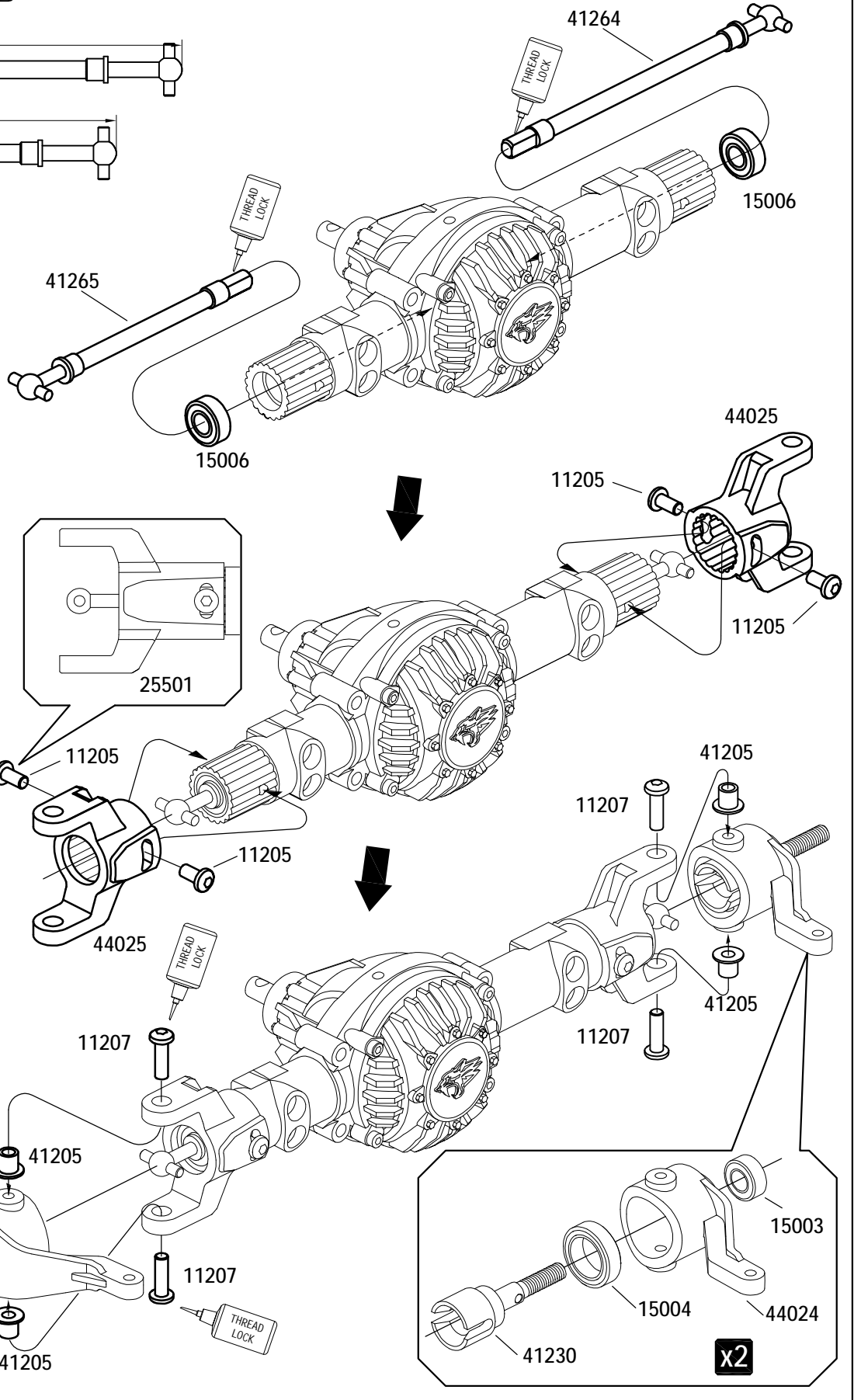
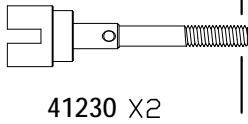
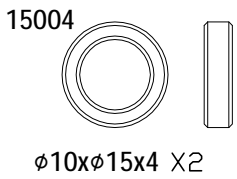
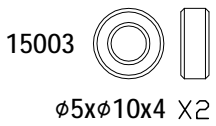
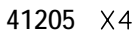
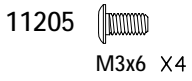
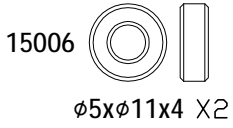
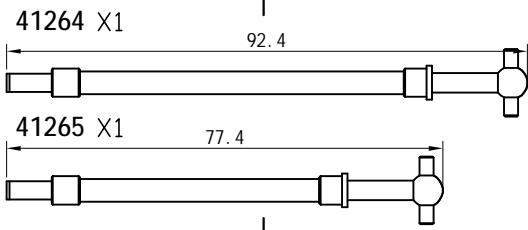

14

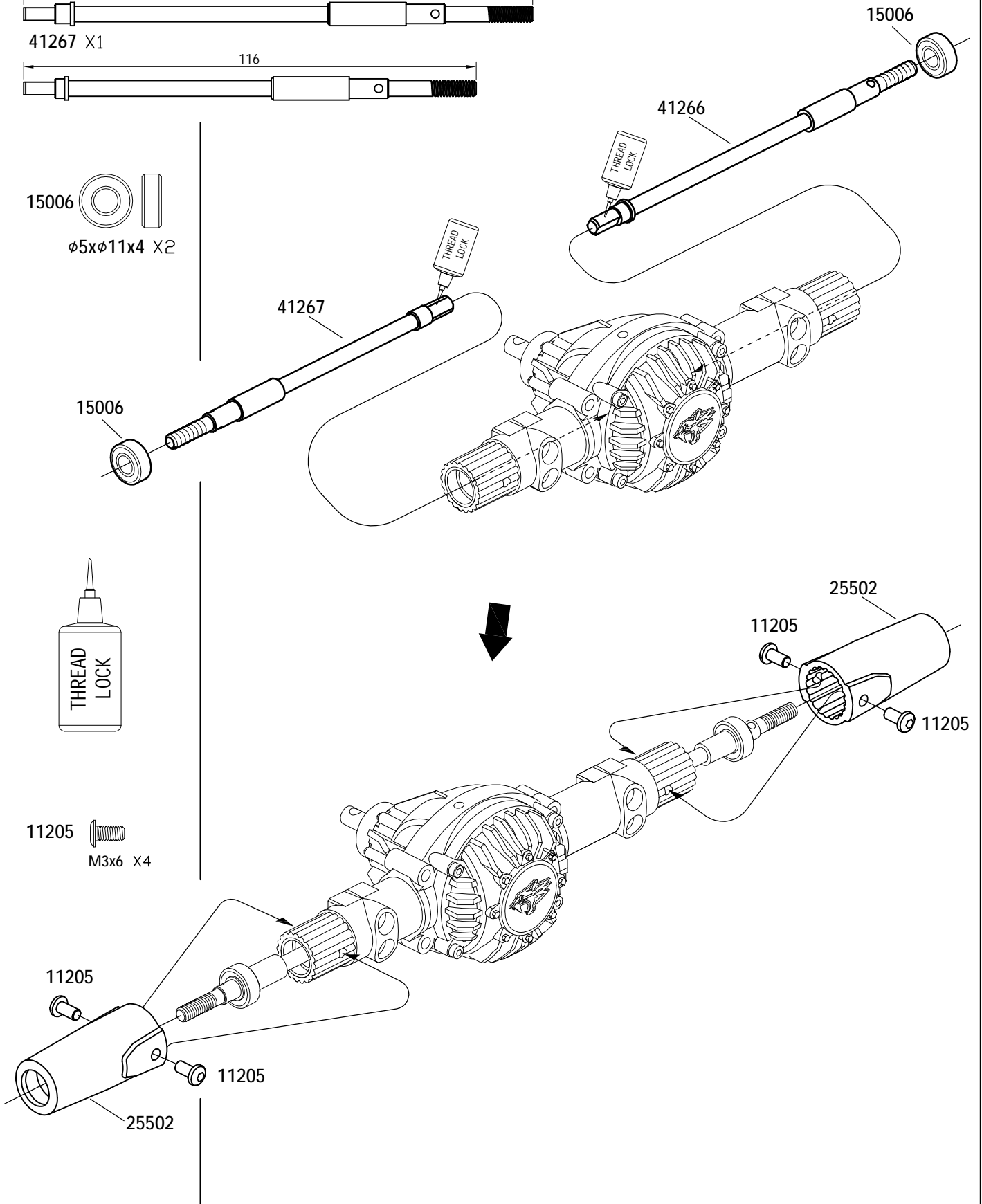
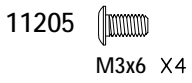
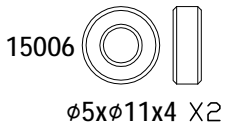
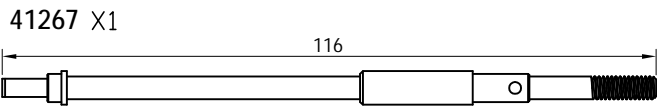
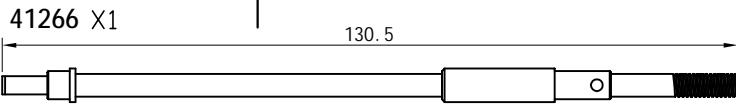



15

12203 
M3 X6

11306 
M3x10 X1

11213 
M3x22 X2

11111 
M3x18 X2

11114 
M3x25 X2

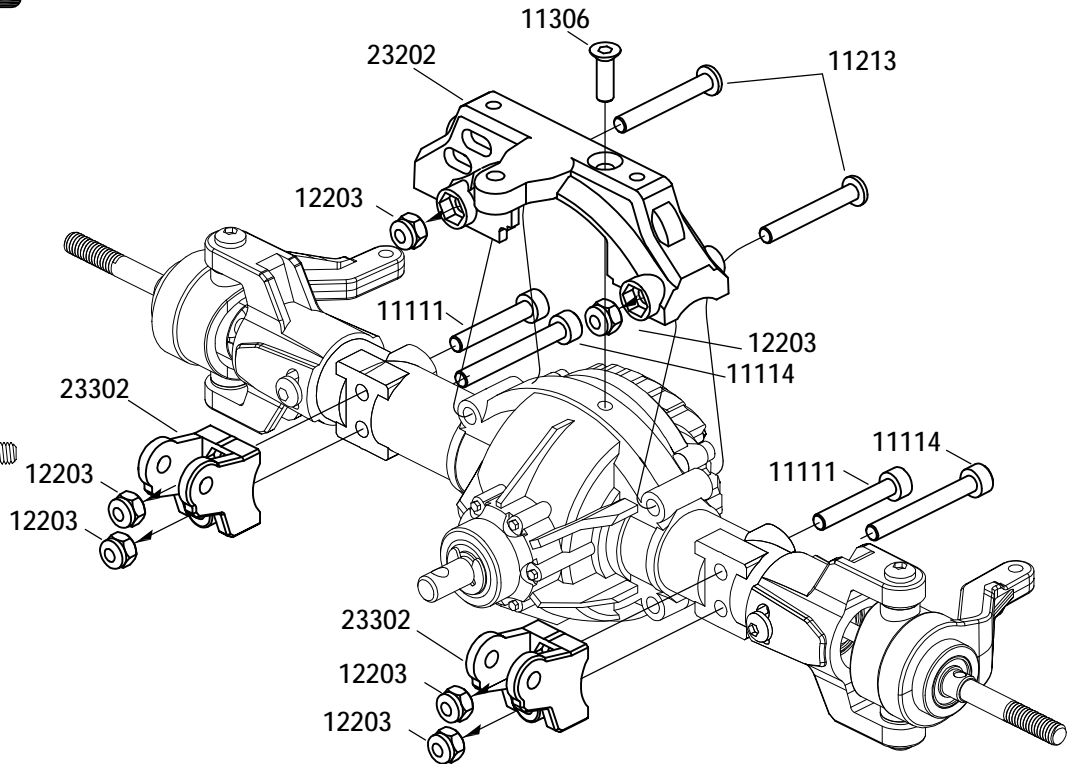

16

12203 
M3 X6

11306 
M3x10 X1

11213 
M3x22 X2

11111 
M3x18 X2

11114 
M3x25 X2

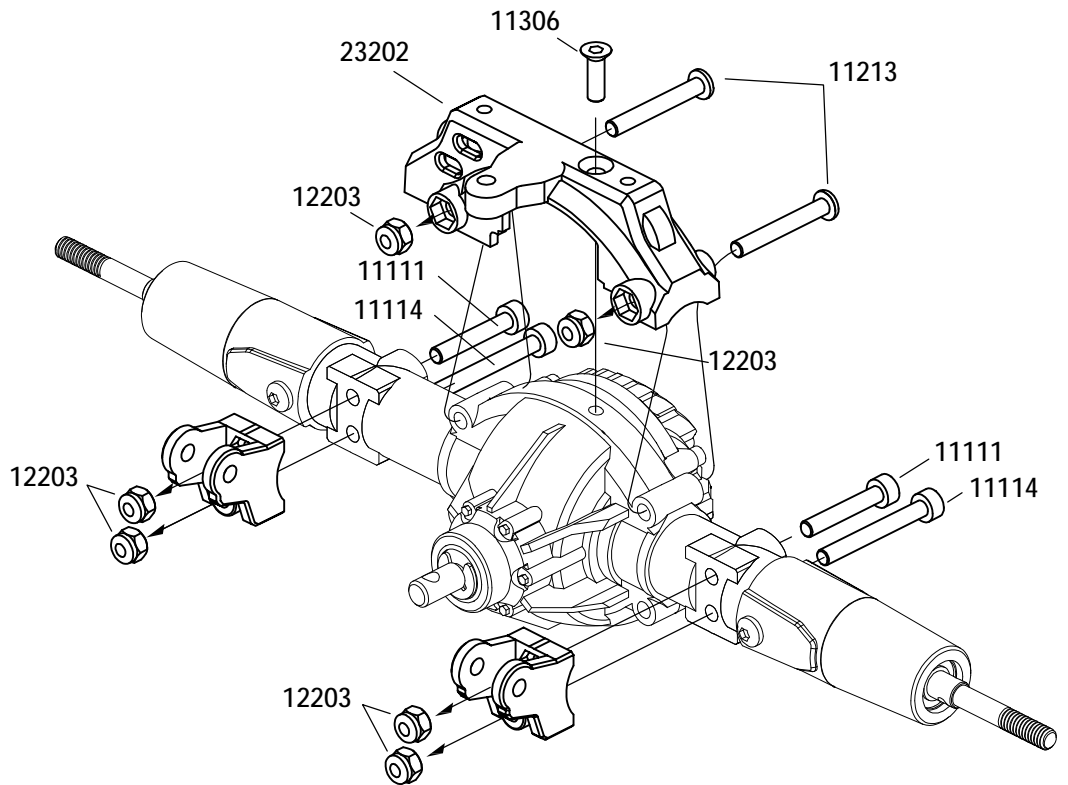

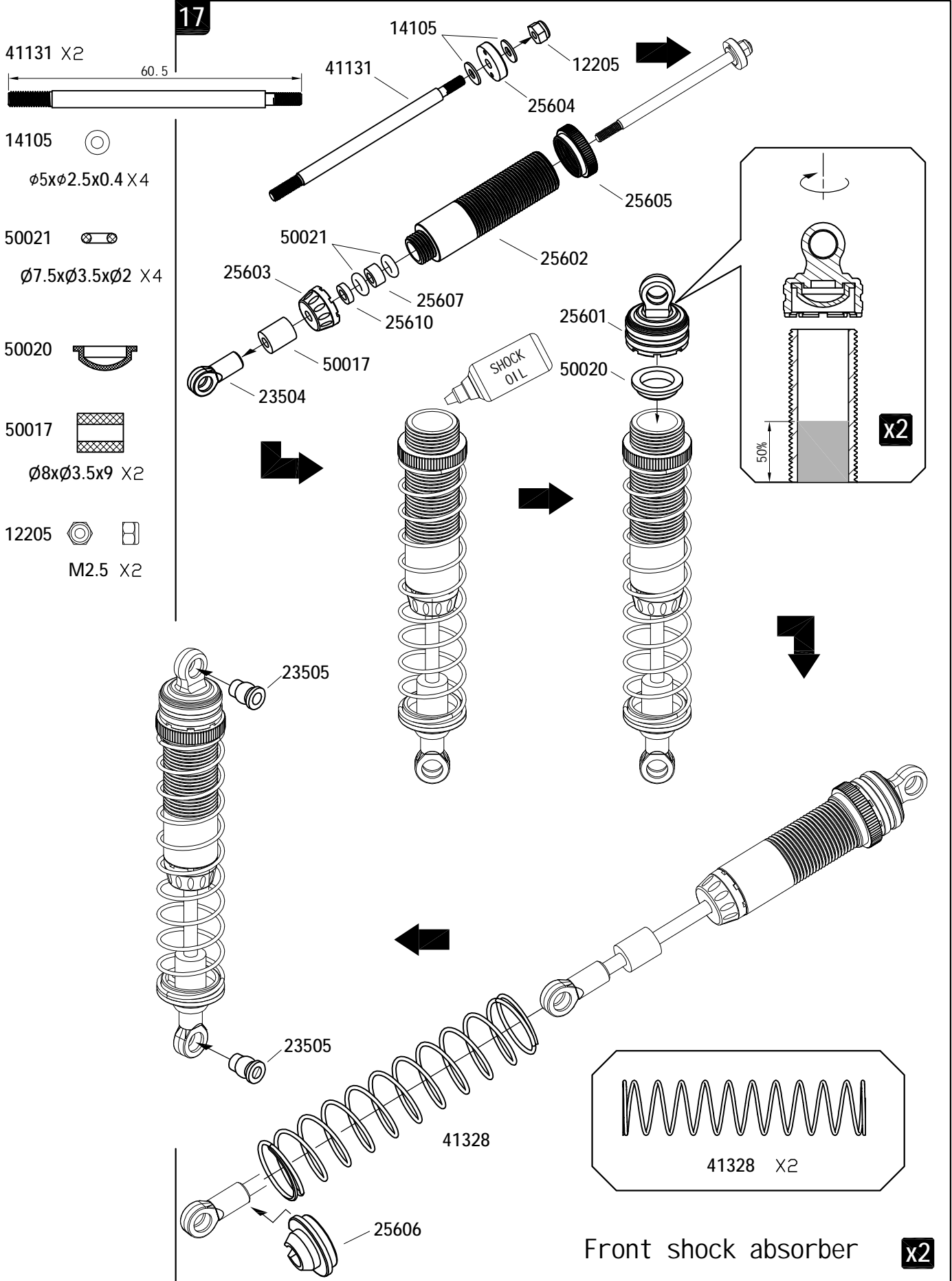

18

41132 X2

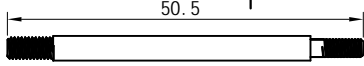

14105



ø5xø2.5x0.4 X4

50021



ø7.5xø3.5xø2 X4

50020



50018



ø8xø3.5x4 X2

12205



M2.5 X2

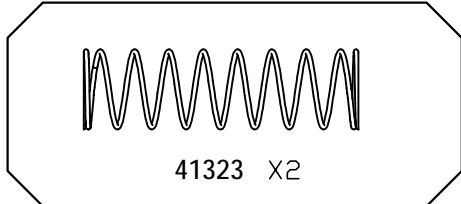
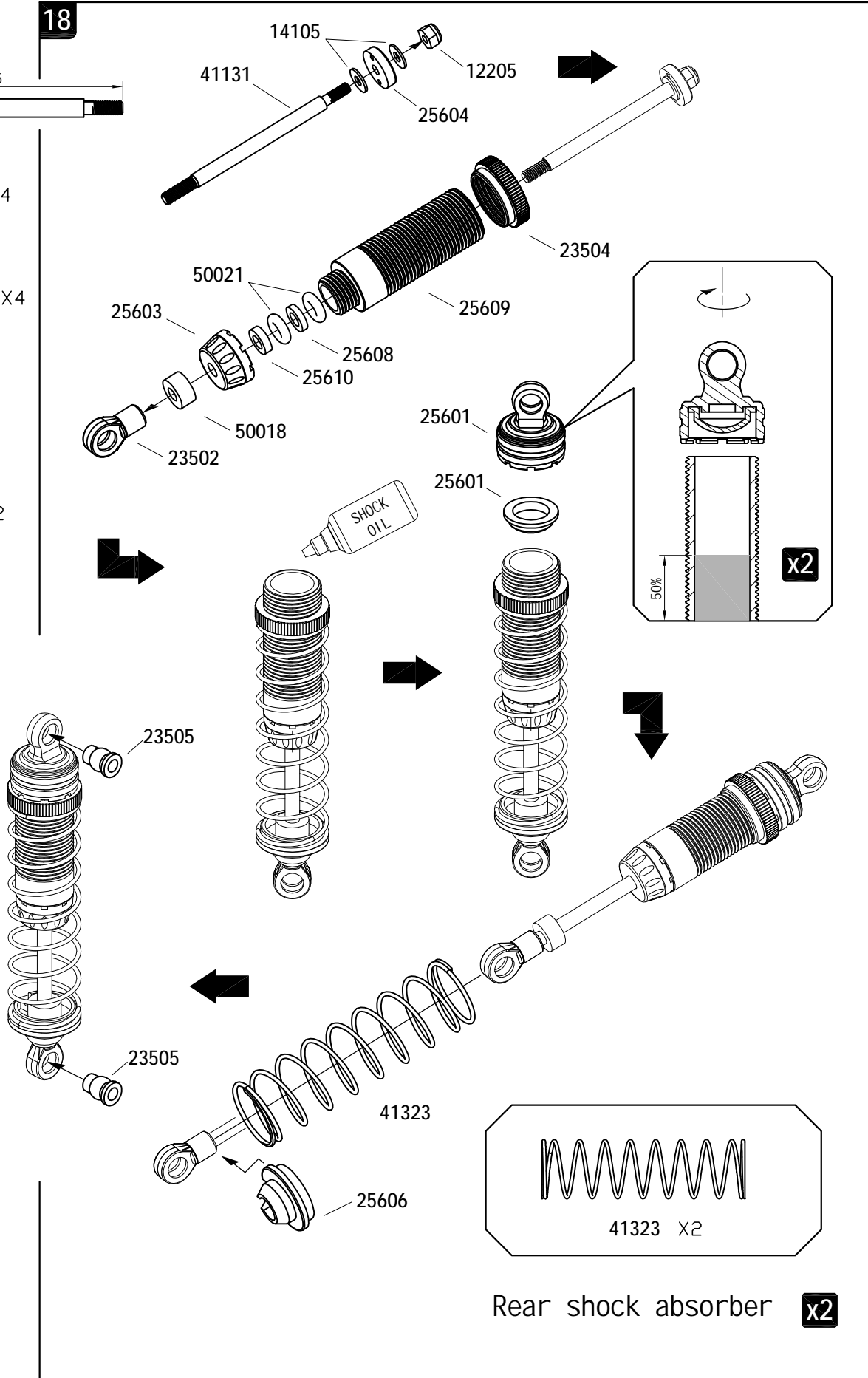

Rear shock absorber X2

19

41154 X2

136.5

41126 X2



5

11407



M3x16 X2

11403



M3x20 X2

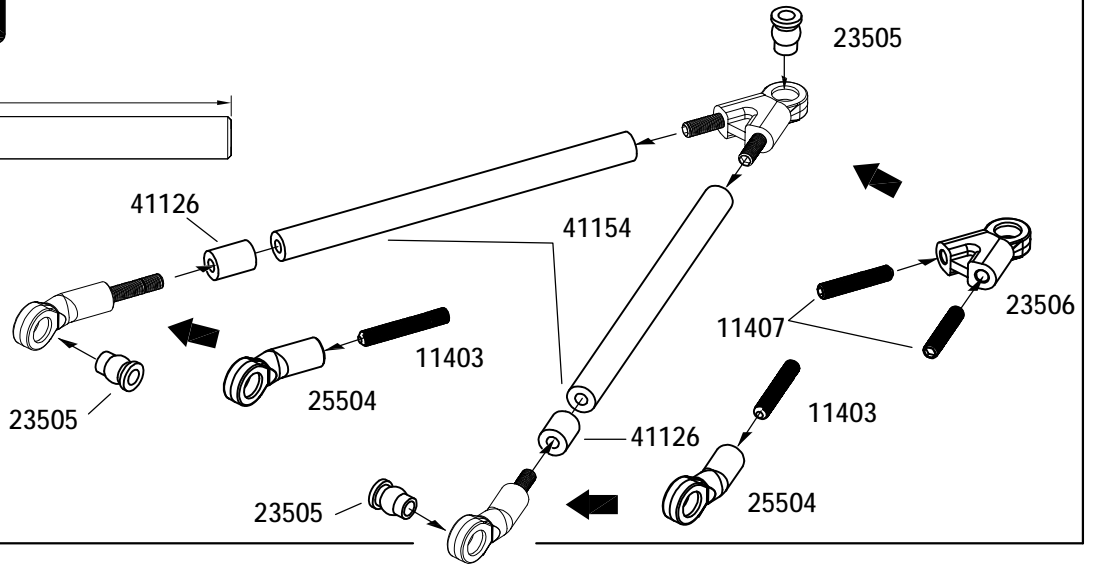

20

41154 X2

136.5

11214



M3x25 X2

12203



M3 X2

11407

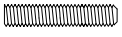

M3x16 X4

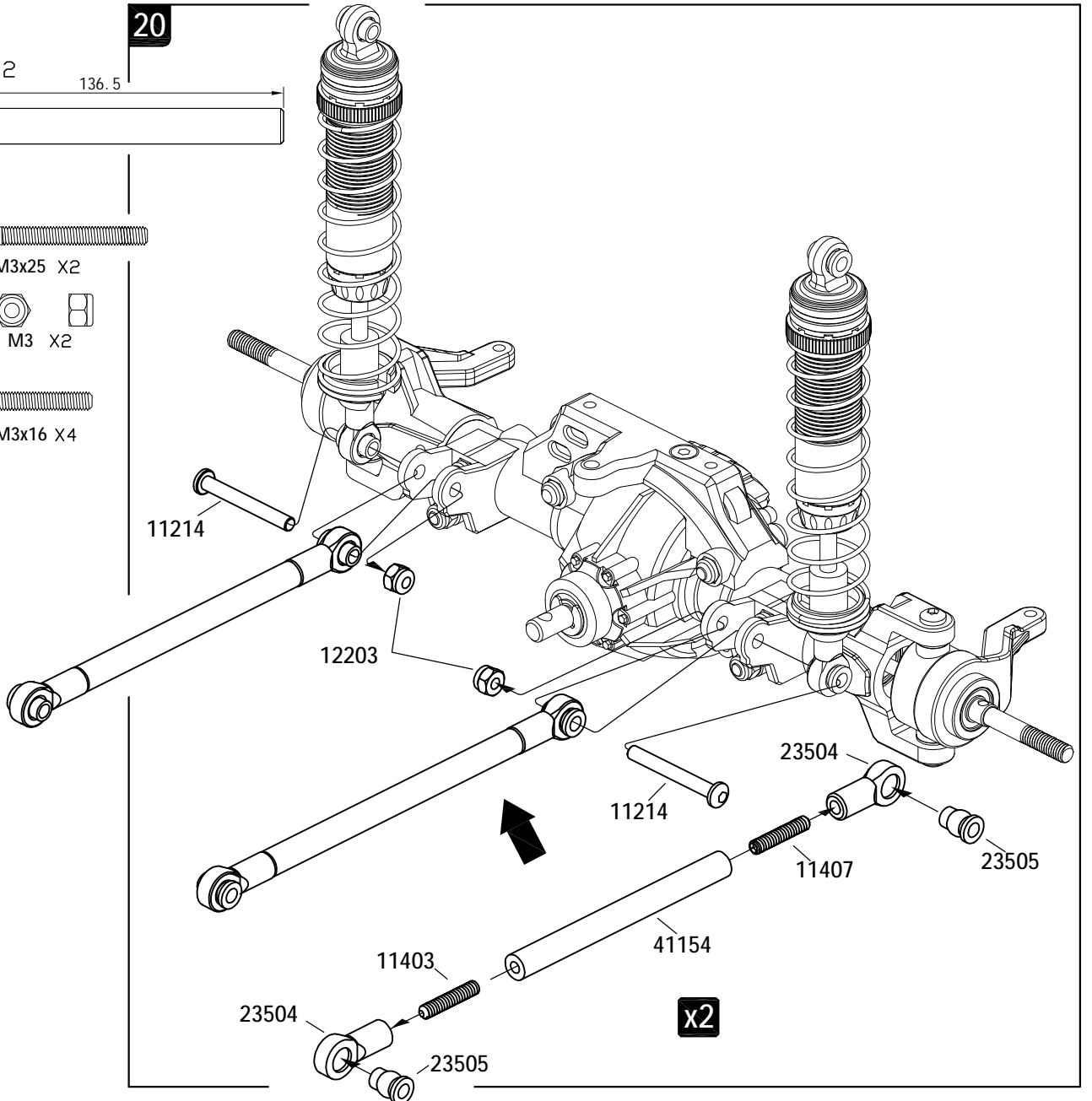

21

11303  M3x8 X2

11206  M3x8 X2

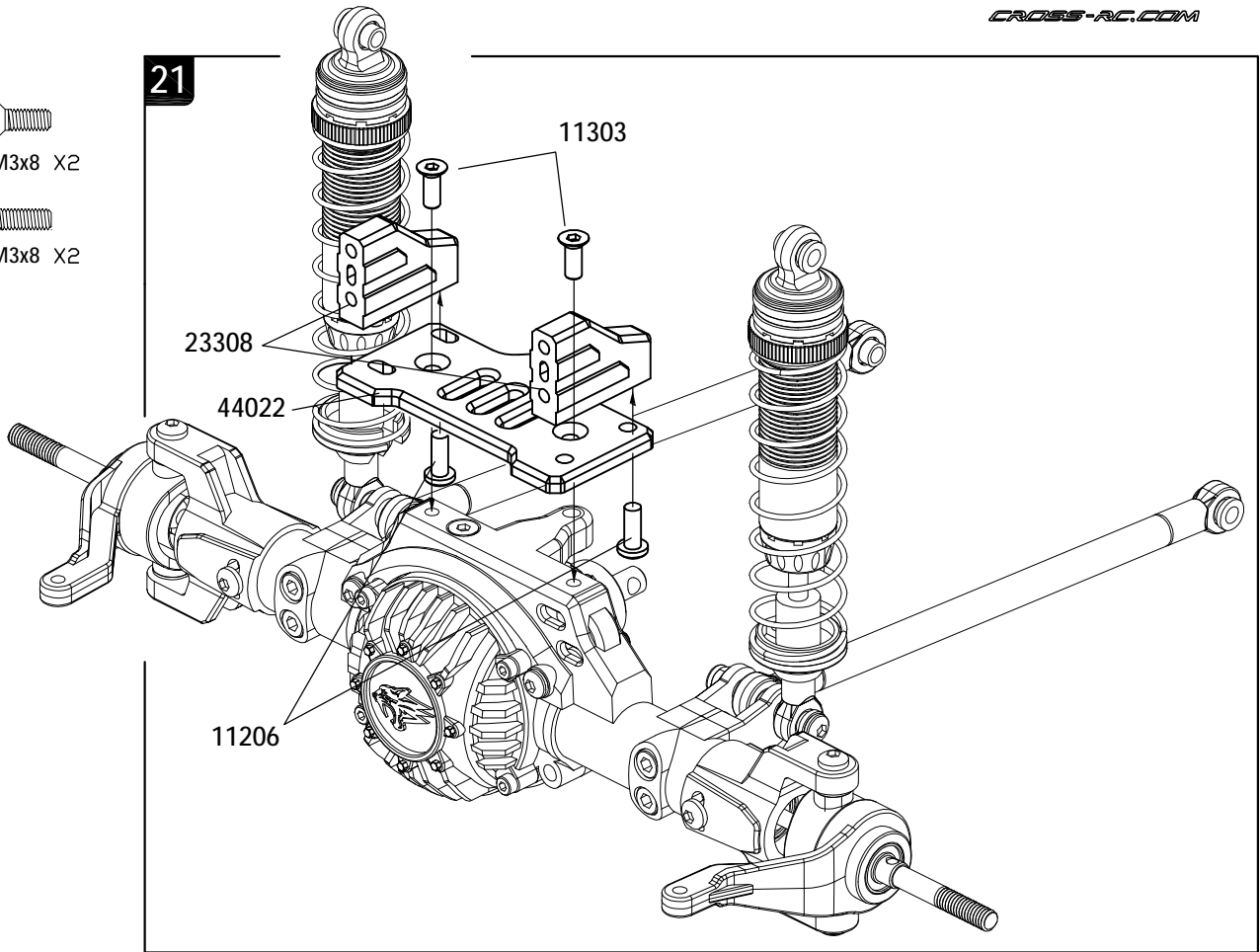

22

12203  M3 X1

11402  M3x10 X1

11211  M3x18 X1

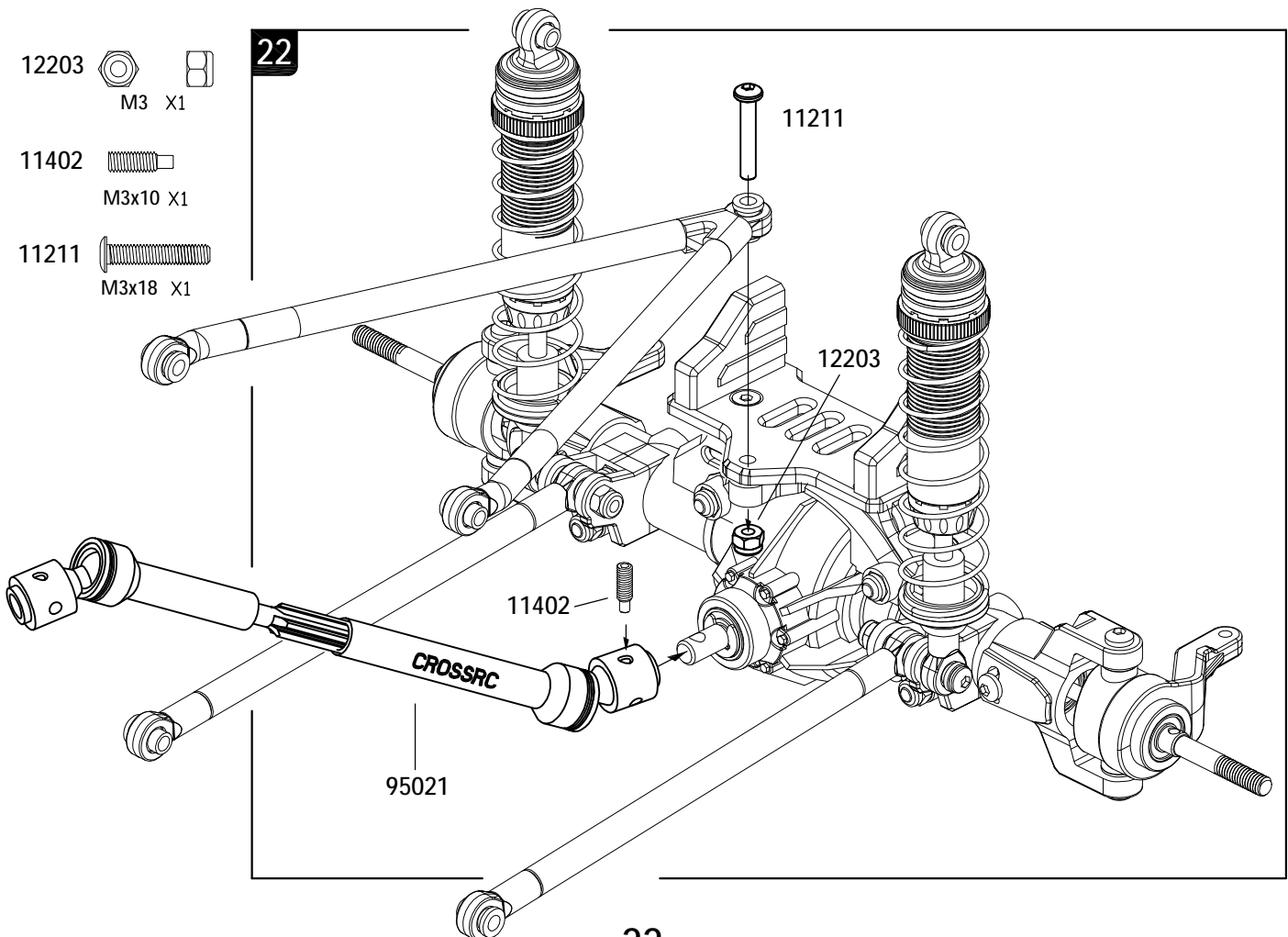

23

11207  M3x10 X4

14102  $\phi 3 \times \phi 7 \times 0.5 \times 4$

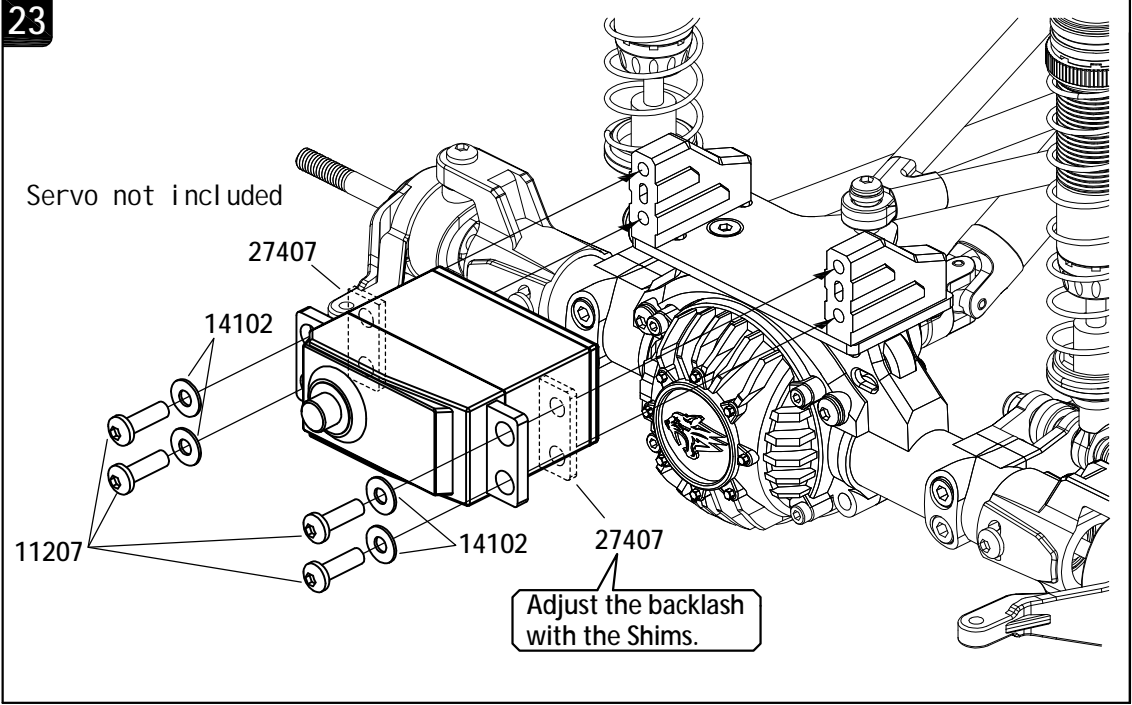

11403  M3x20 X1

11407  M3x16 X3

41332  3

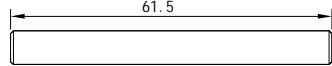
41113 X1  61.5

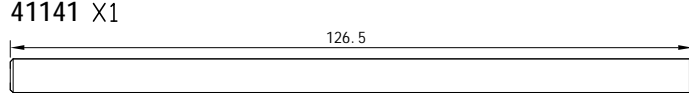
41141 X1  126.5

24

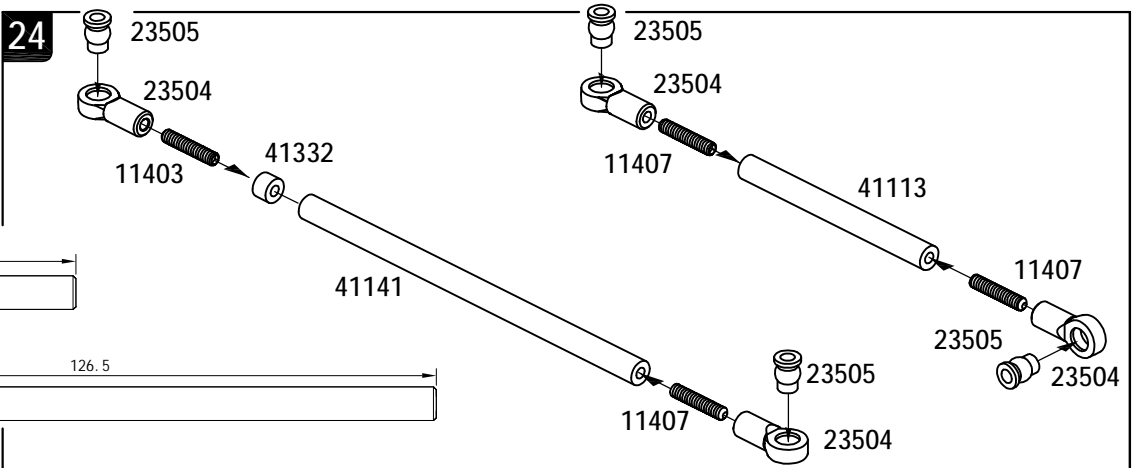

11205  M3x6 X1

11210  M3x16 X2

11214  M3x25 X1

12203  M3 X1

41126 X2  5

25

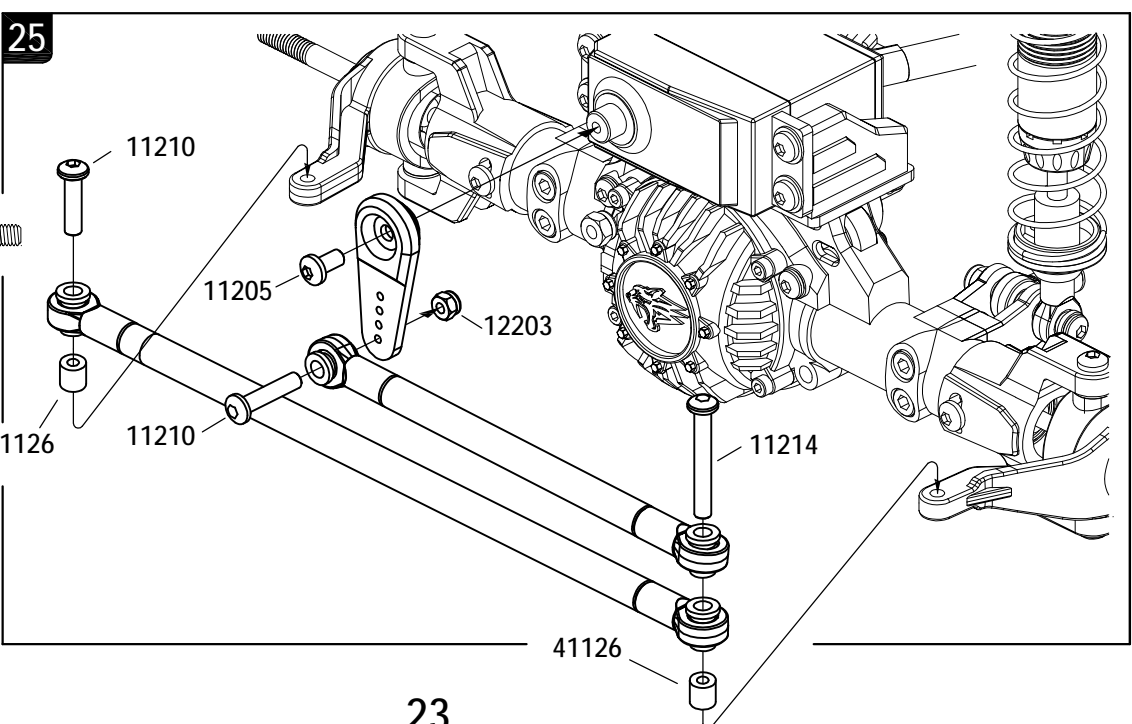

26

11407 M3x16 X2

11403 M3x20 X2

41126 X2
5

41155 X2
112

27

11303 M3x8 X2

11402 M3x10 X1

11407 M3x16 X4

11211 M3x18 X1

11214 M3x25 X2

12203 M3 X3

41155 X2
112

X2

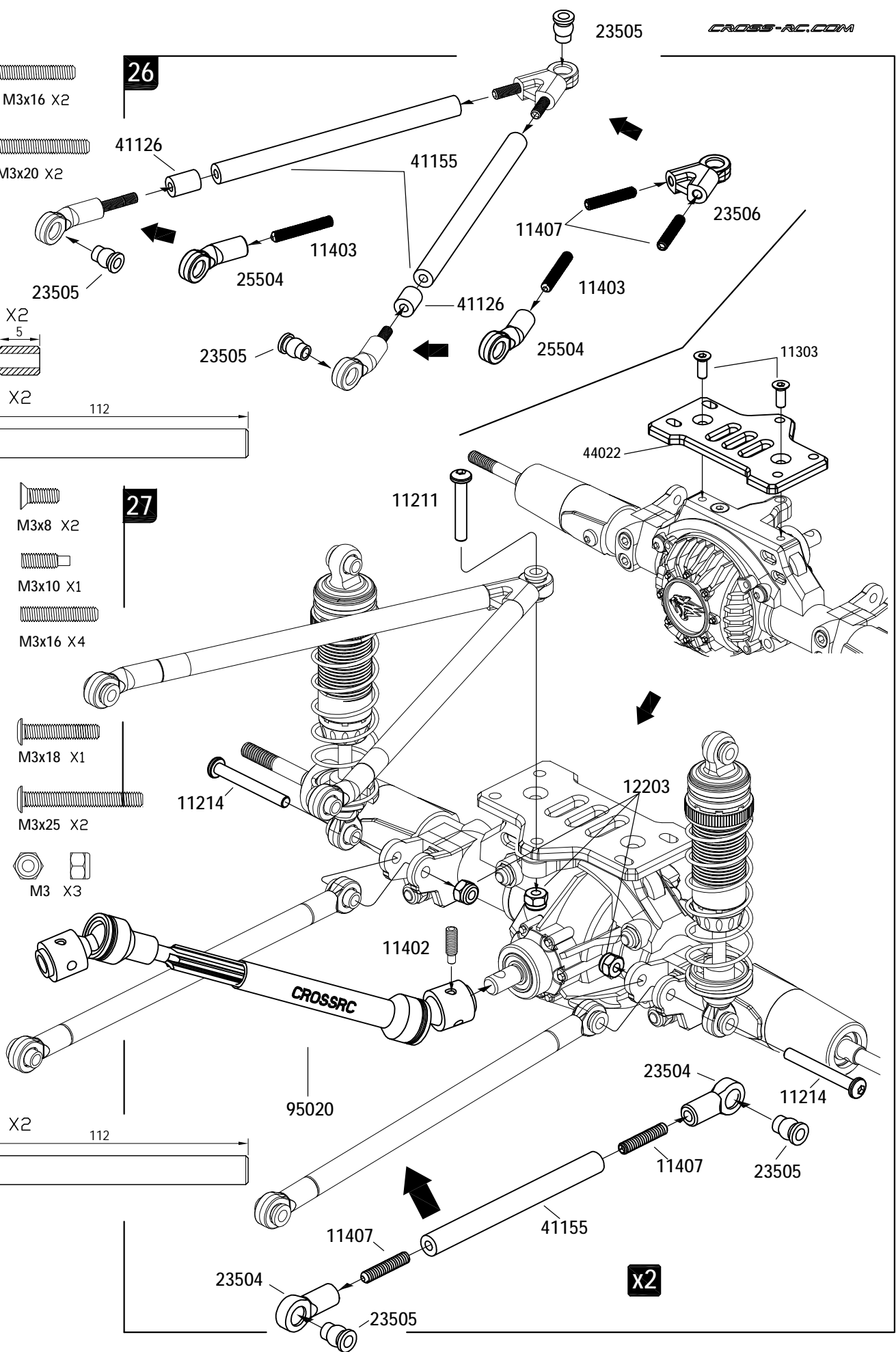

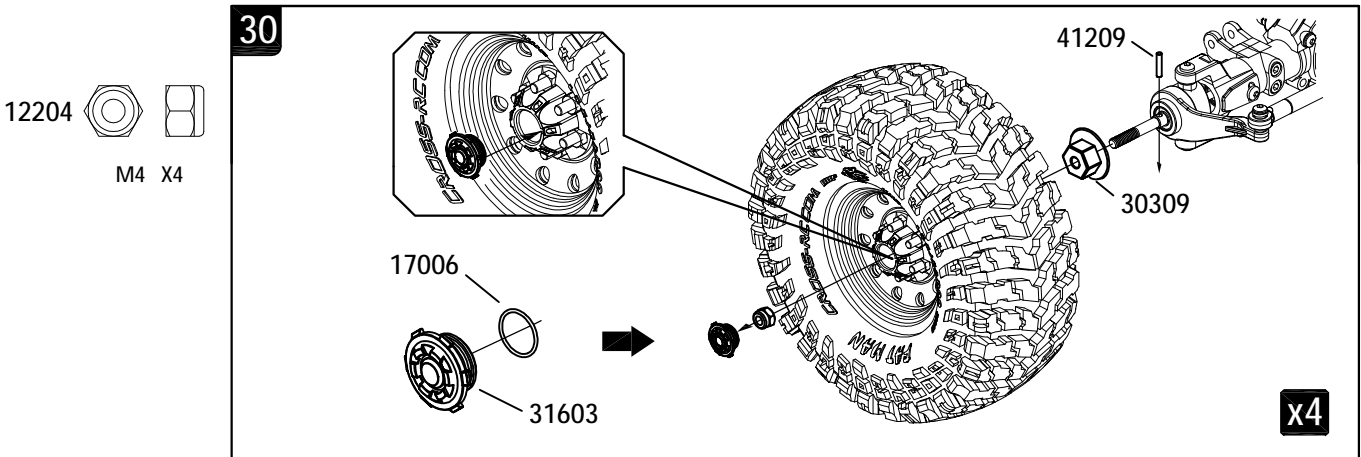
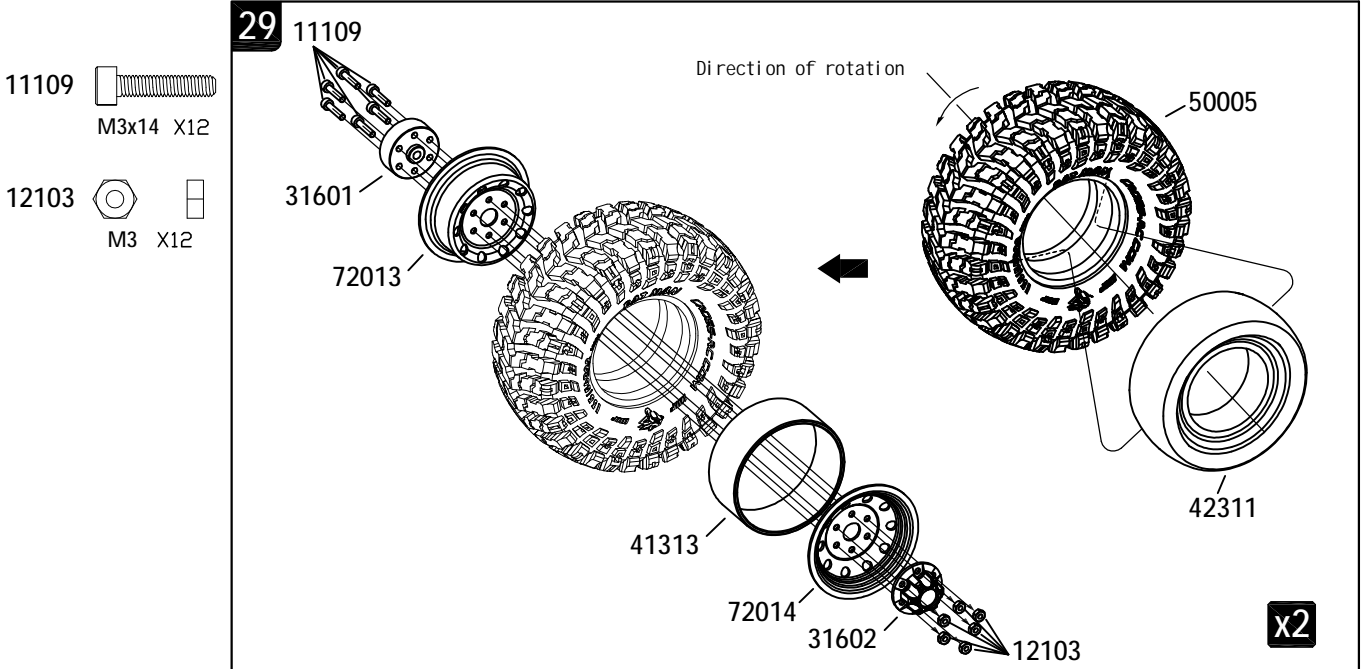
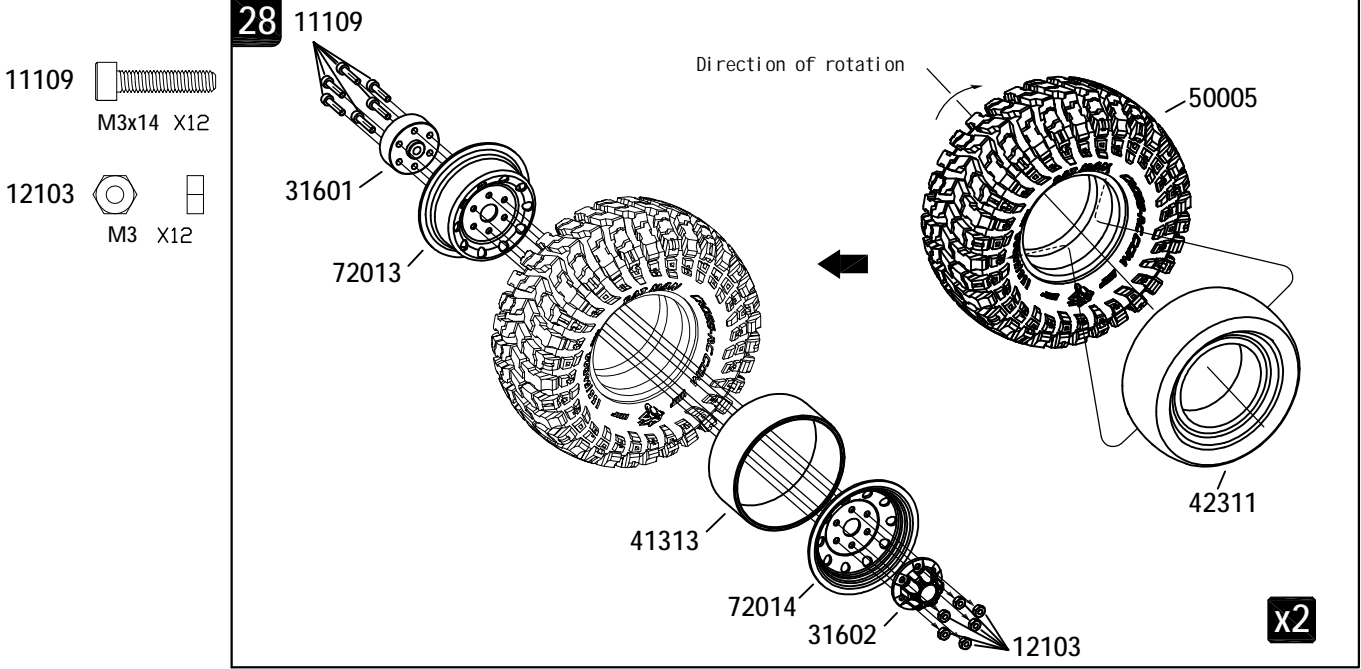



31

11209 
M3x14 X4

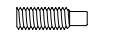
11214 
M3x25 X2

11402 
M3x10 X1

12203 
M3 X2

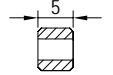
41126 X2

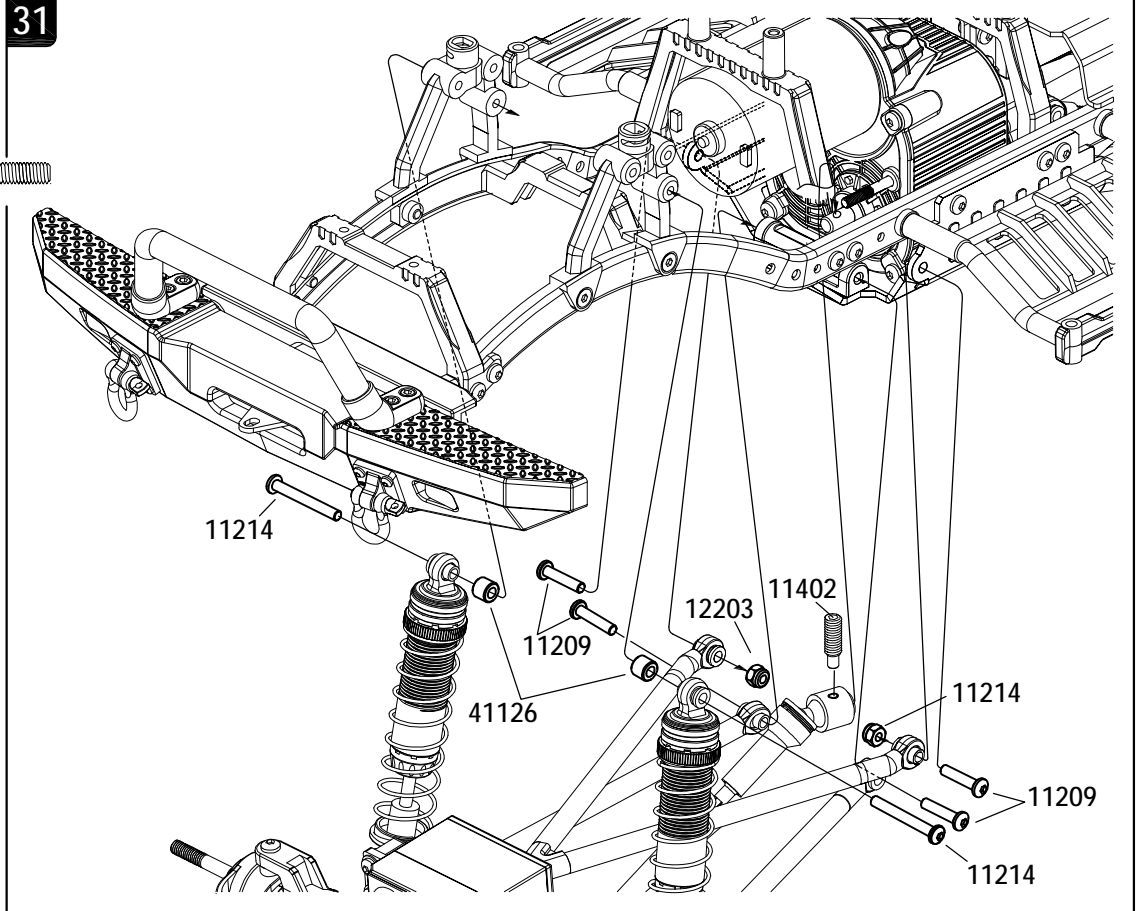

32

11209 
M3x14 X4

11214 
M3x25 X2

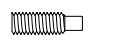
11402 
M3x10 X1

12203 
M3 X2

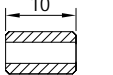
41127 X2

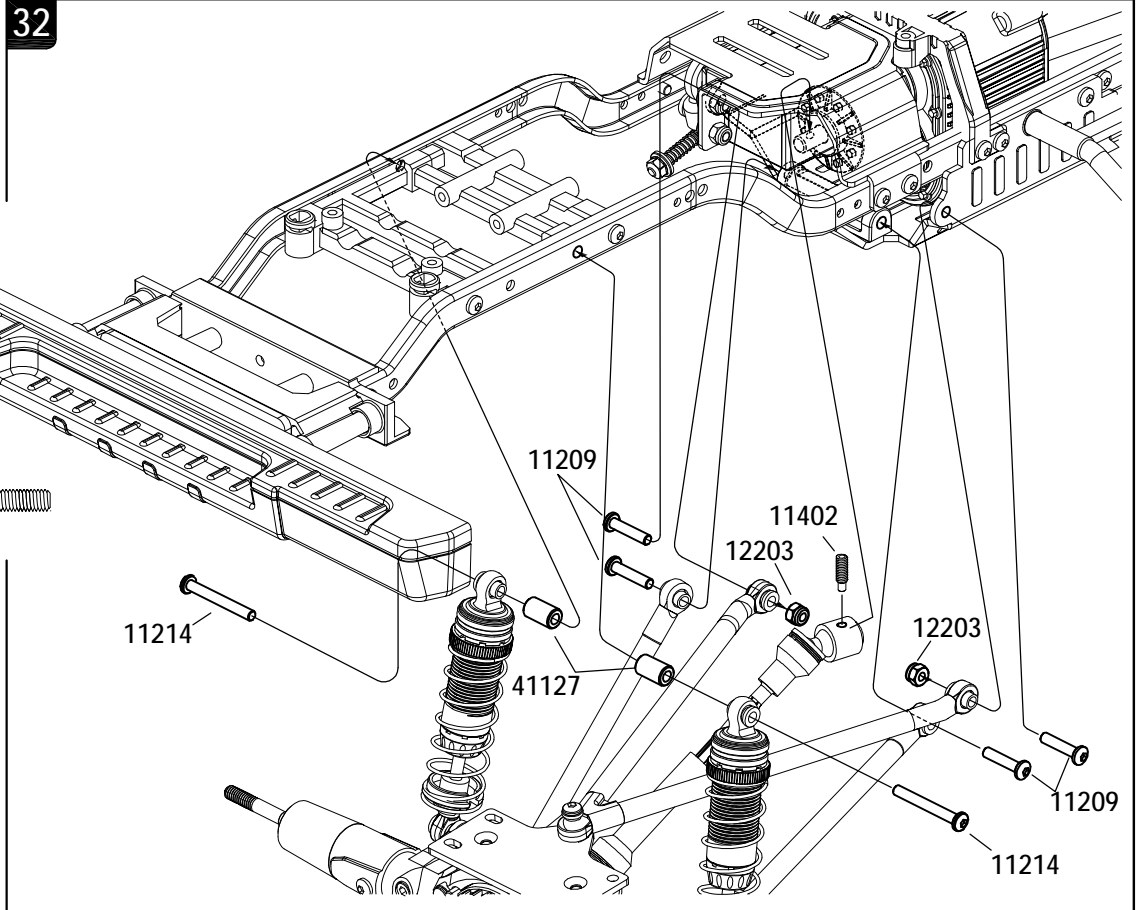

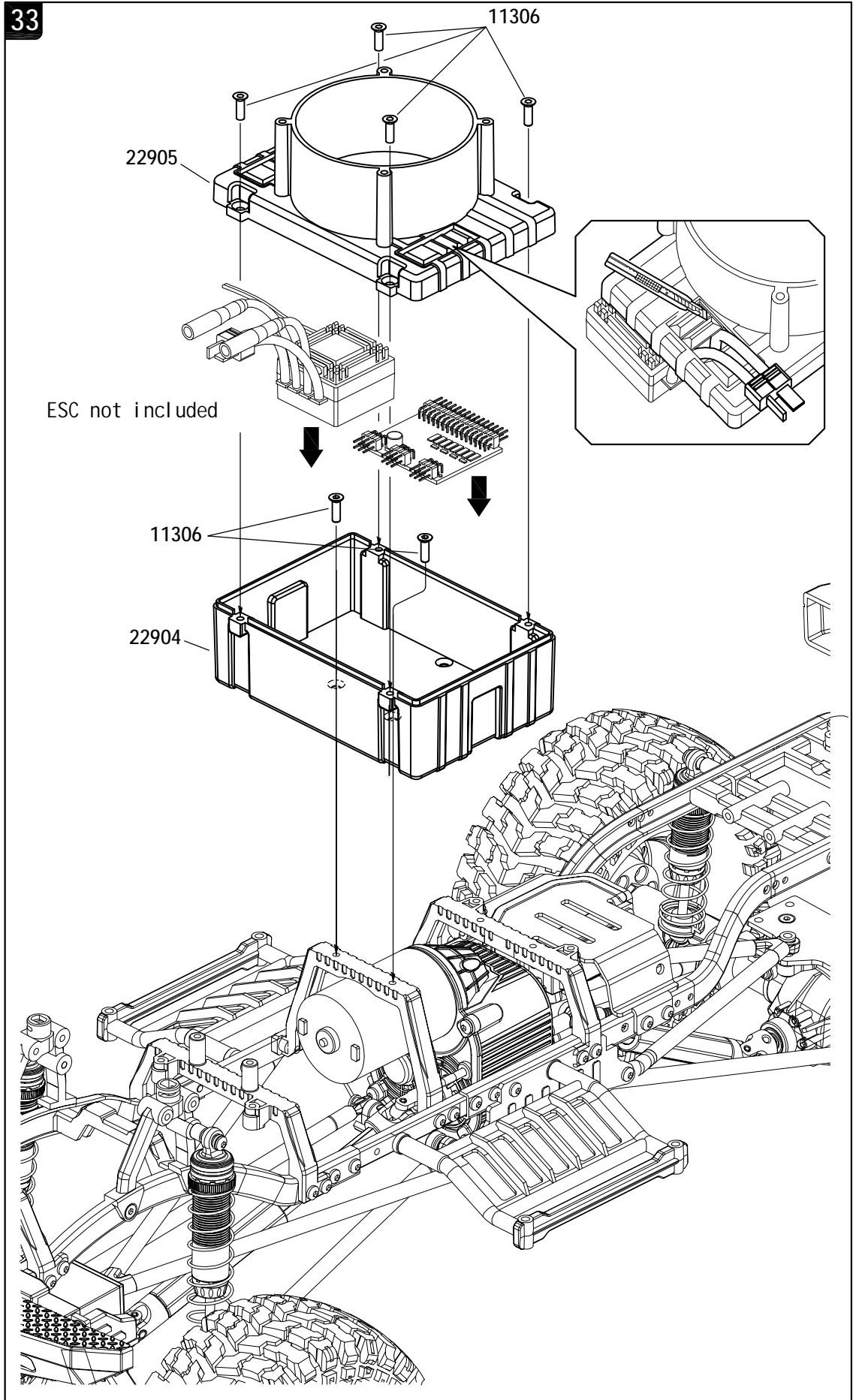

33

11306 
M3x10 X6



34

11303 
M3x8 X4

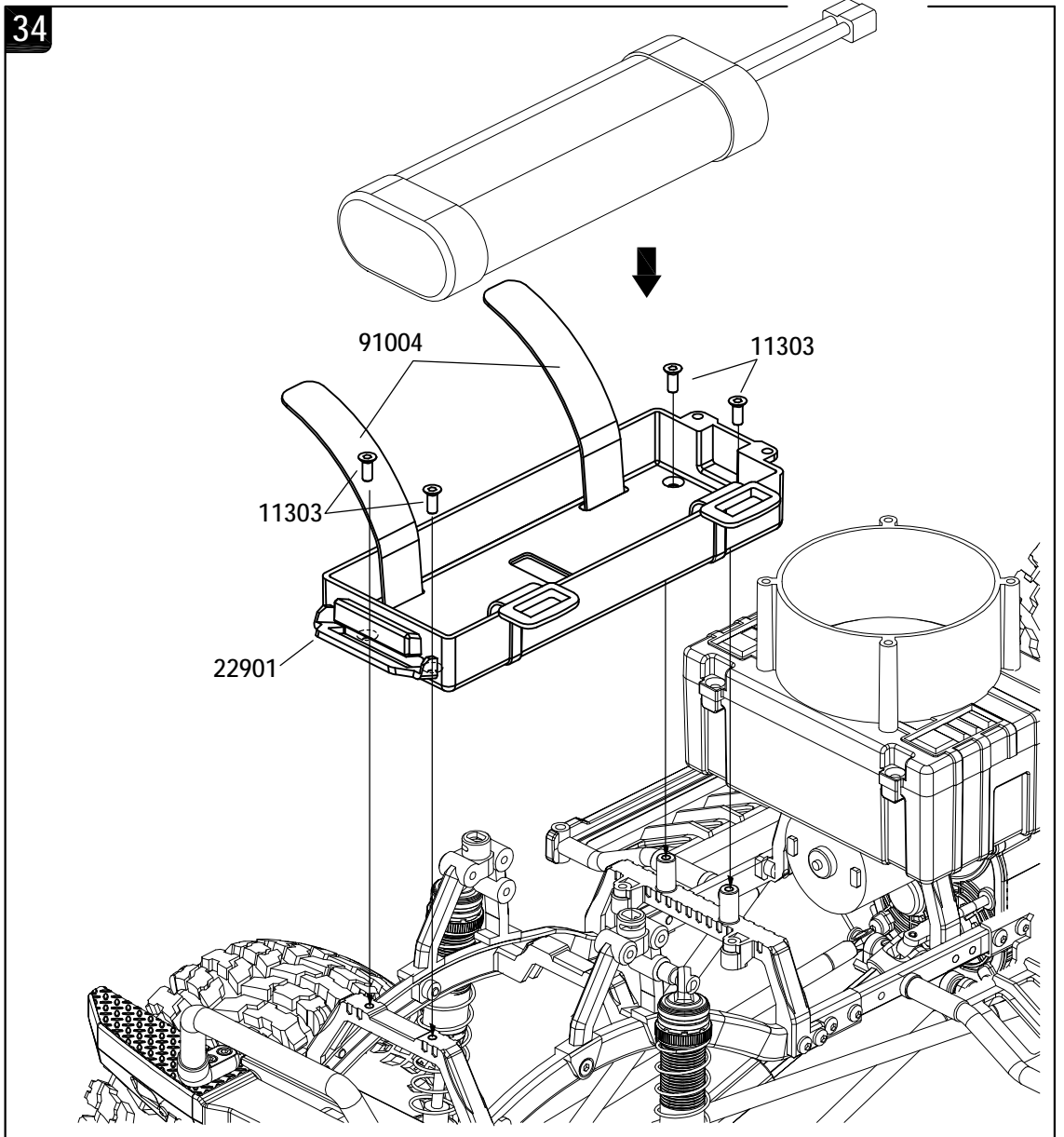

35

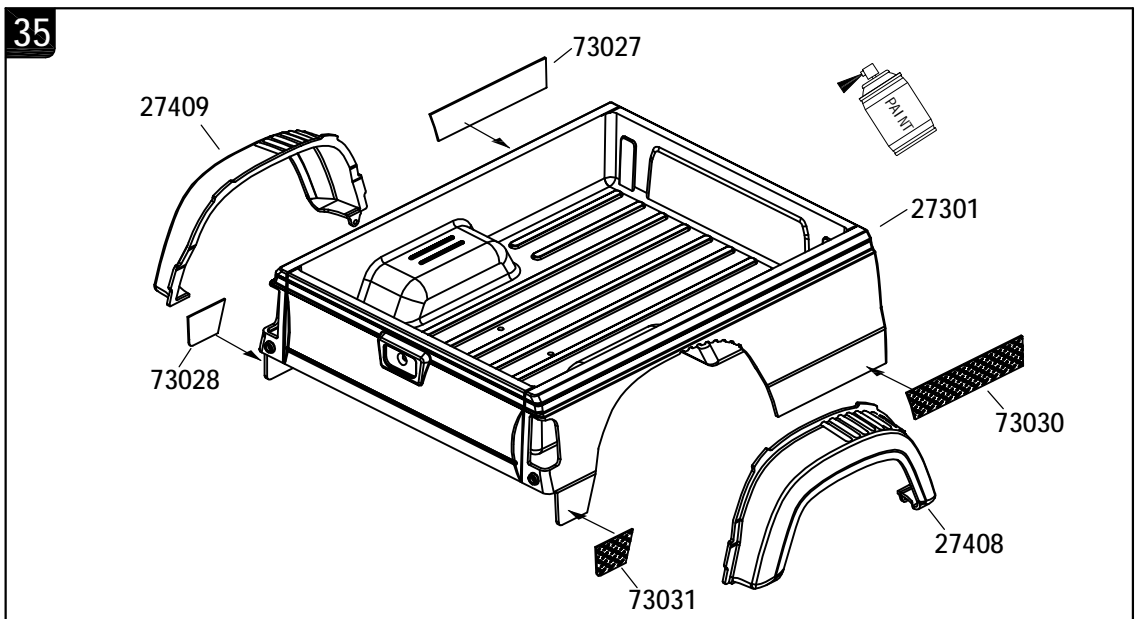
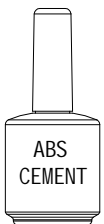

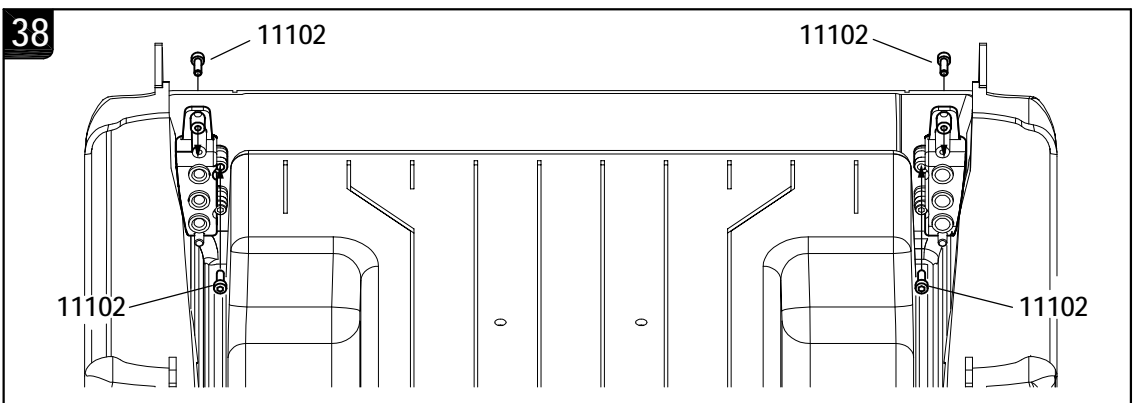
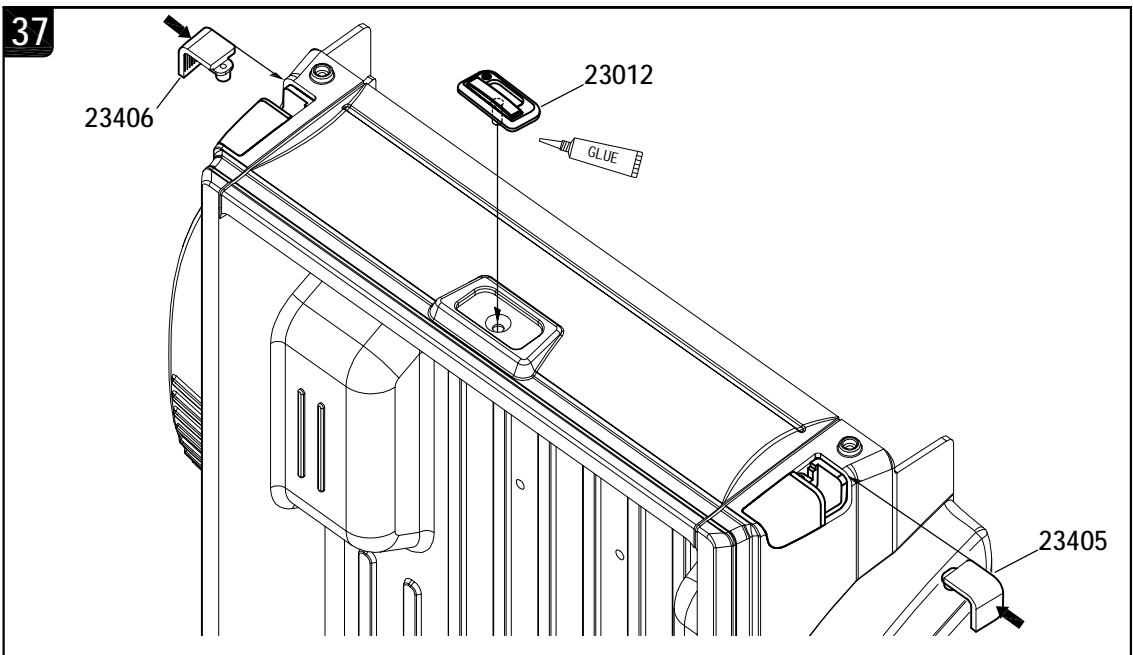
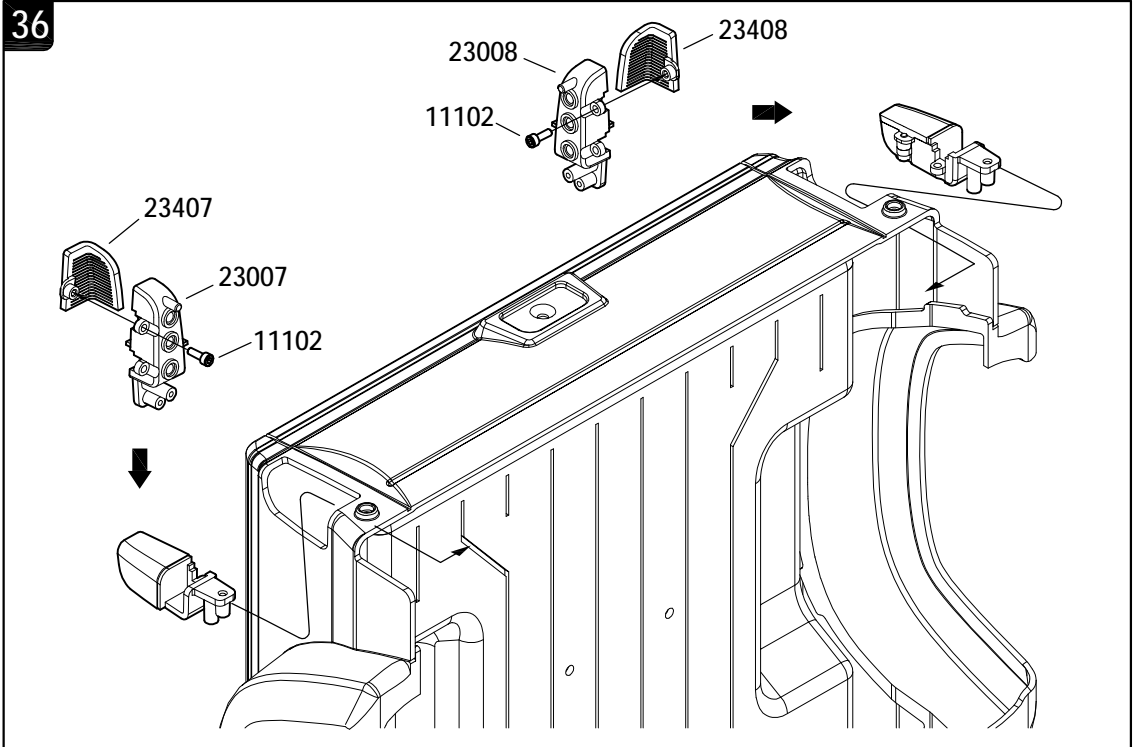

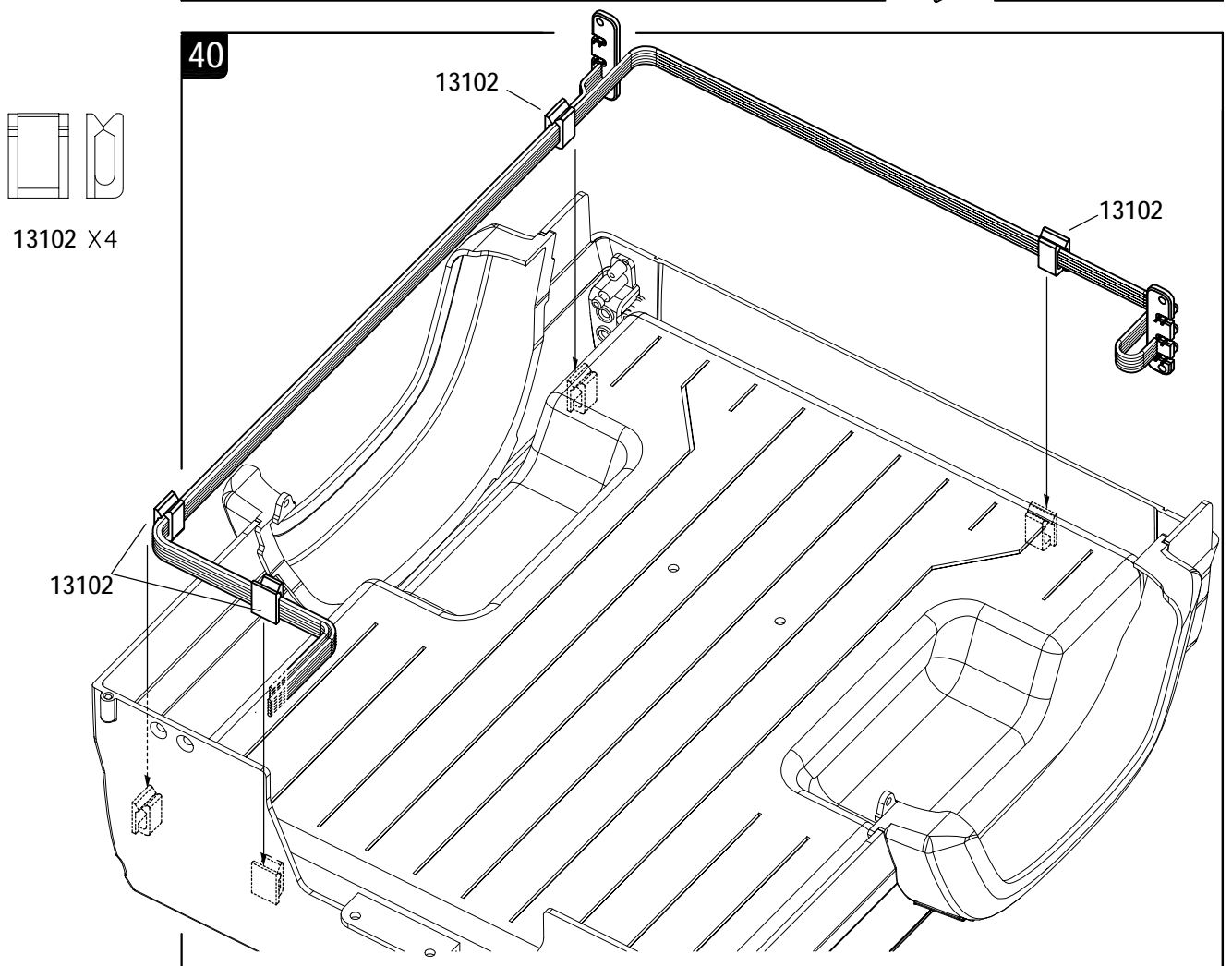
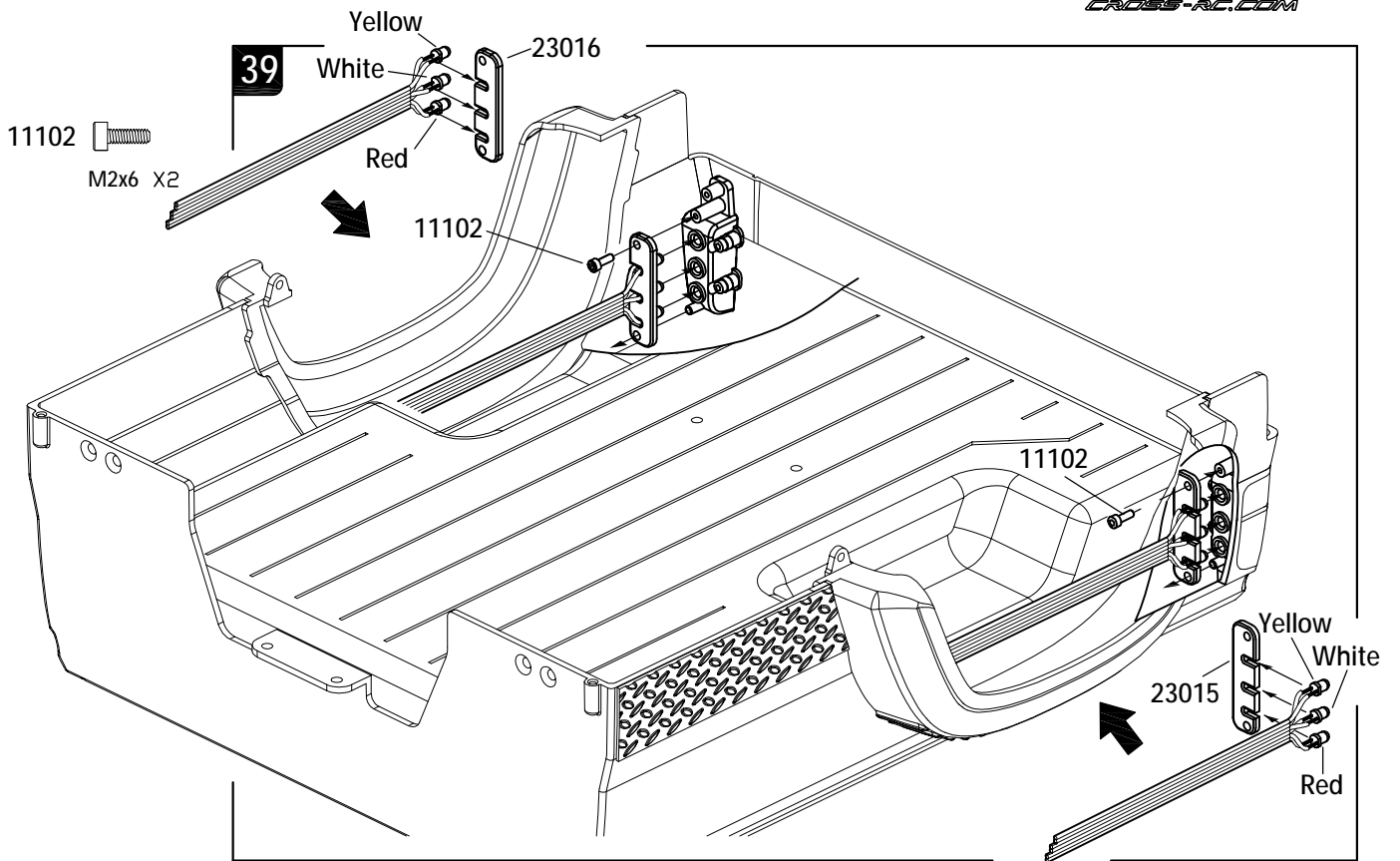



41

11206 
M3x8 X4

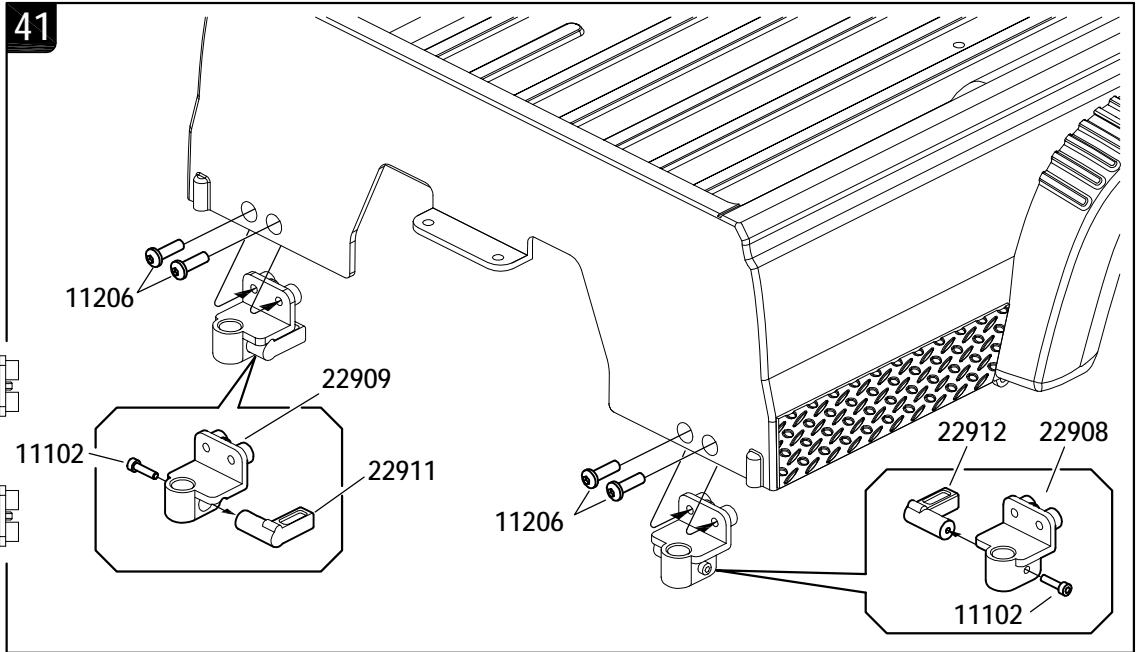
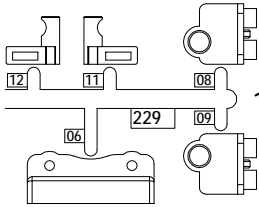
11102 
M2x6 X2



42

11206 
M3x8 X4

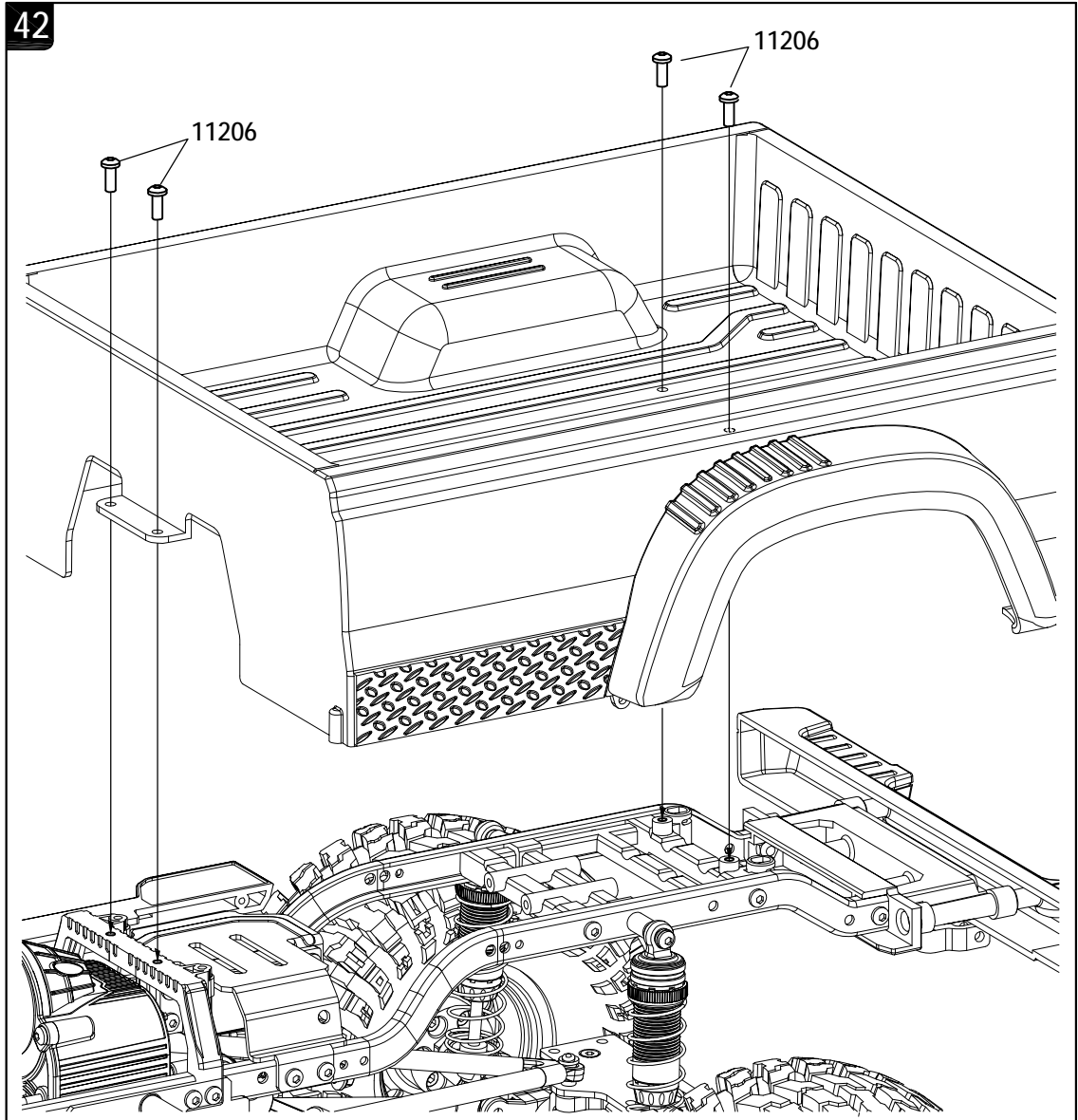

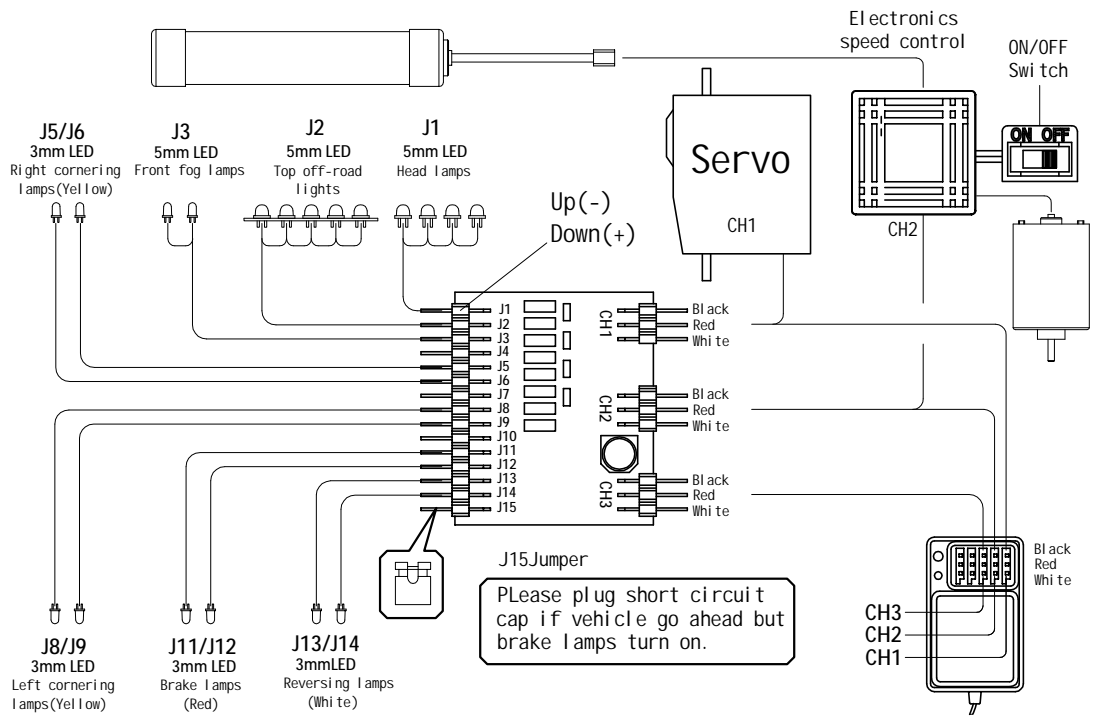

43

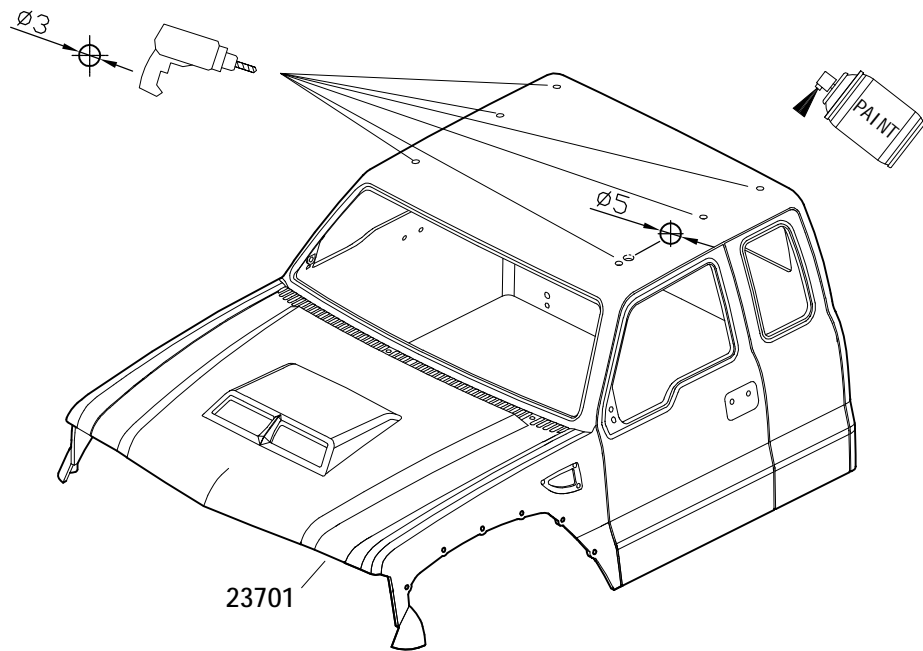

44



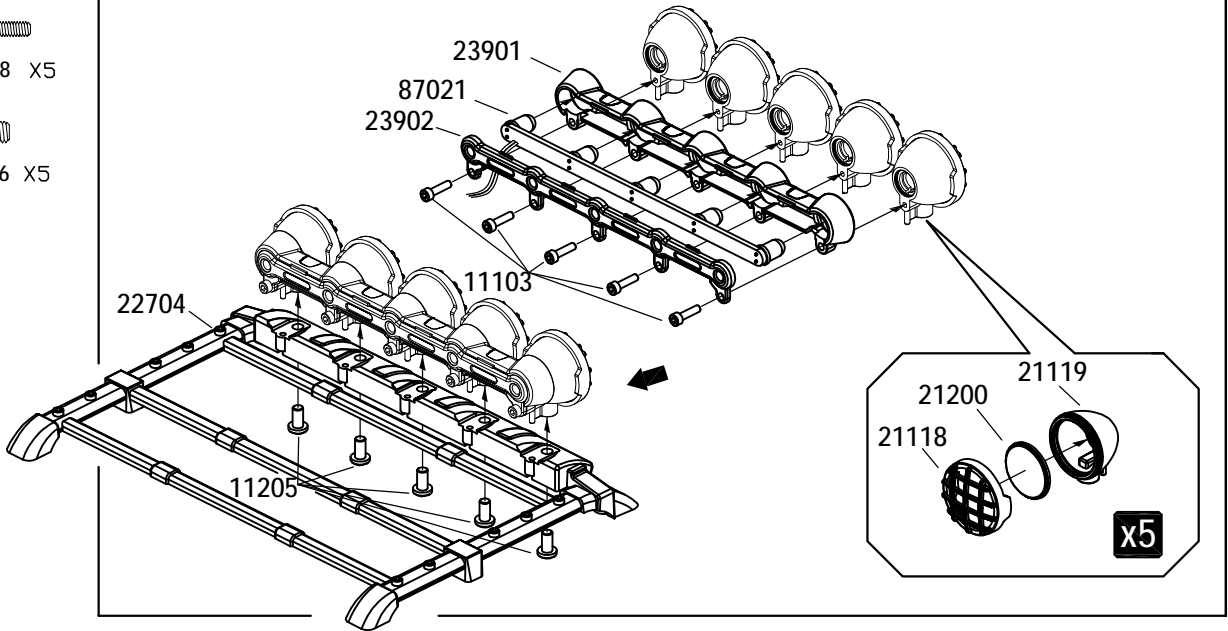

45

- 11103  M2x8 X5
- 11205  M3x6 X5



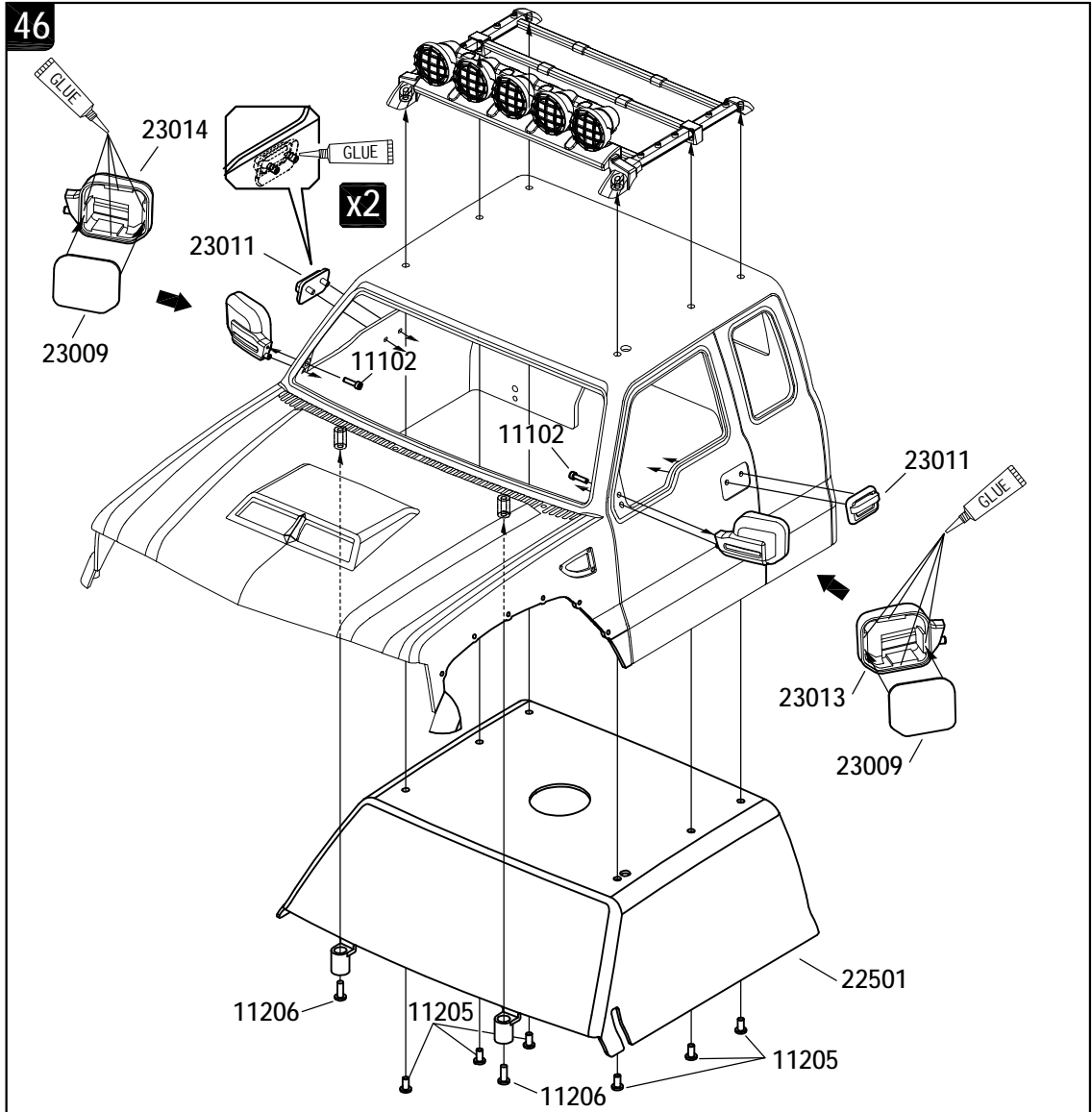

46

- 11102  M2x6 X2
- 11205  M3x6 X6
- 11206  M3x8 X2



47

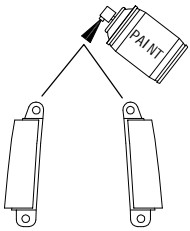

- 11101  M2x4 X6
- 11102  M2x6 X12

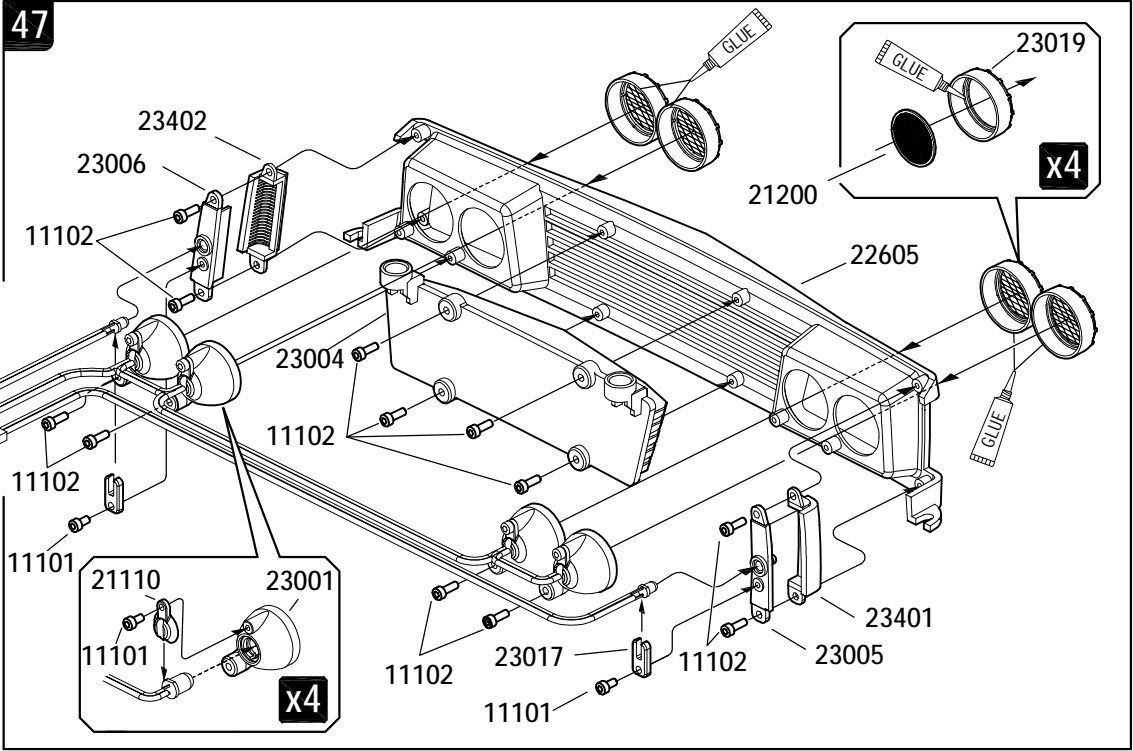

23401 23402



48

- 11205  M3x6 X2
- 11206  M3x8 X4
- 11306  M3x10 X2

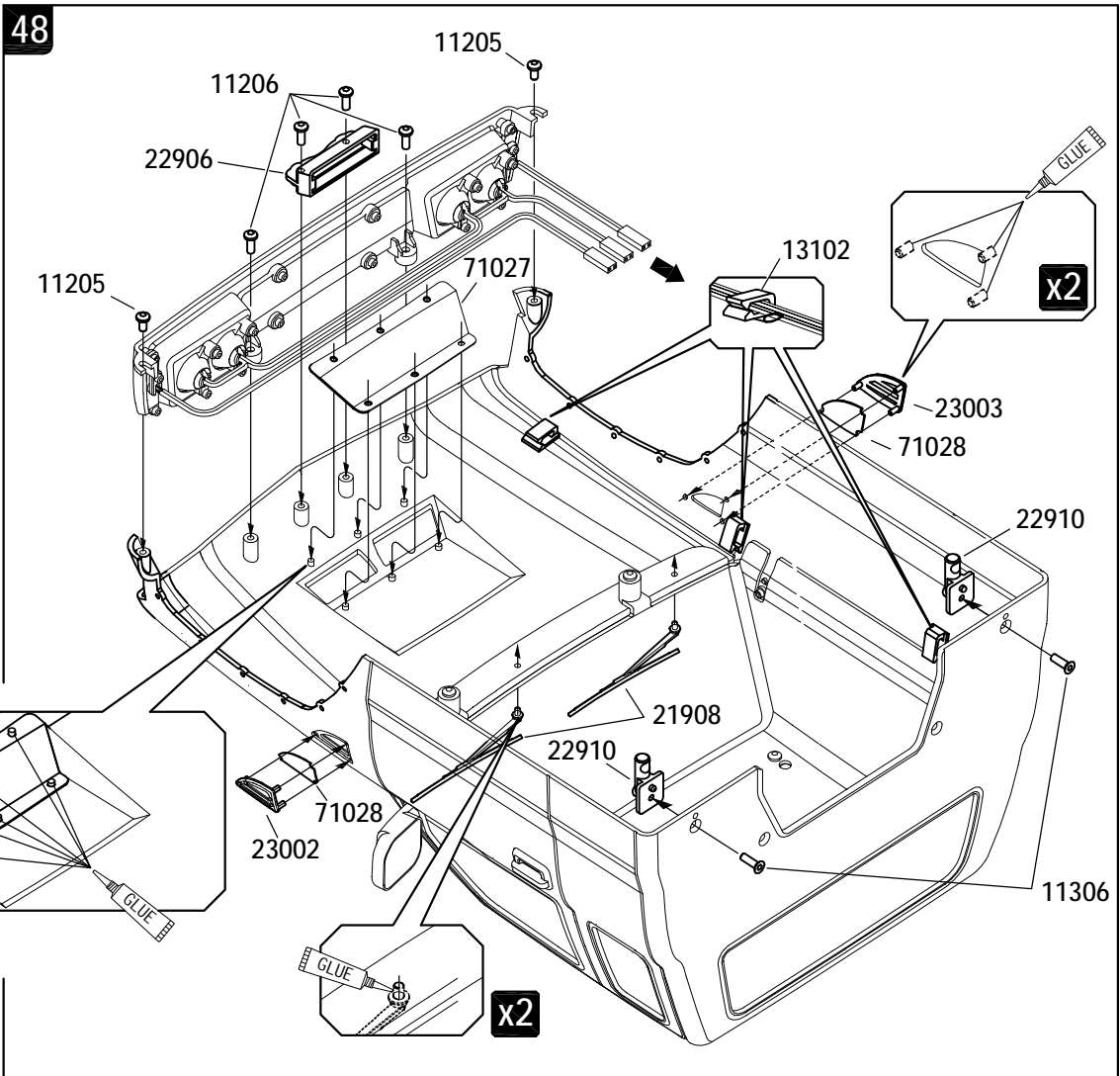
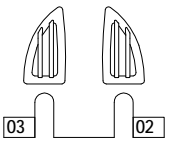

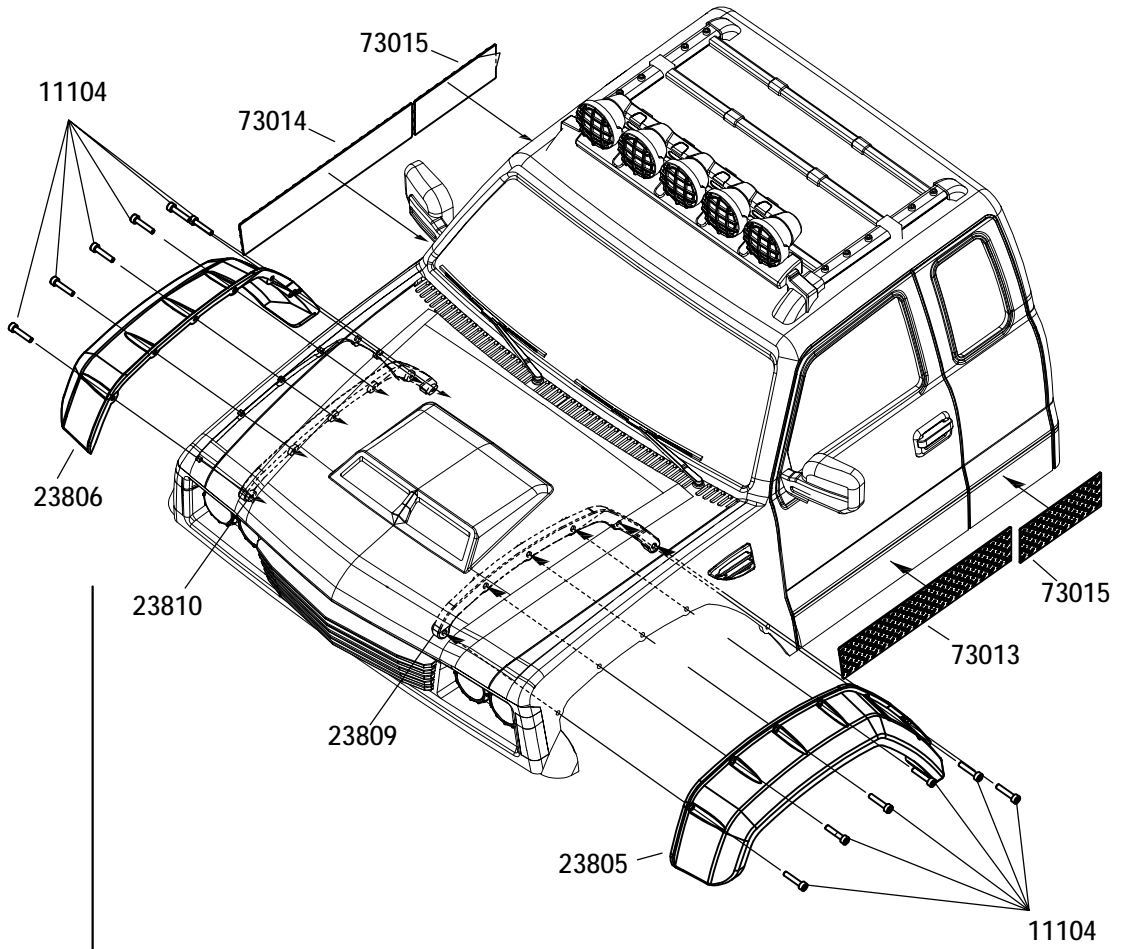

49

11104 
M2x10 X12



50

- 11127  M2.5x7 X4
- 11211  M3x18 X4
- 12203  M3 X4

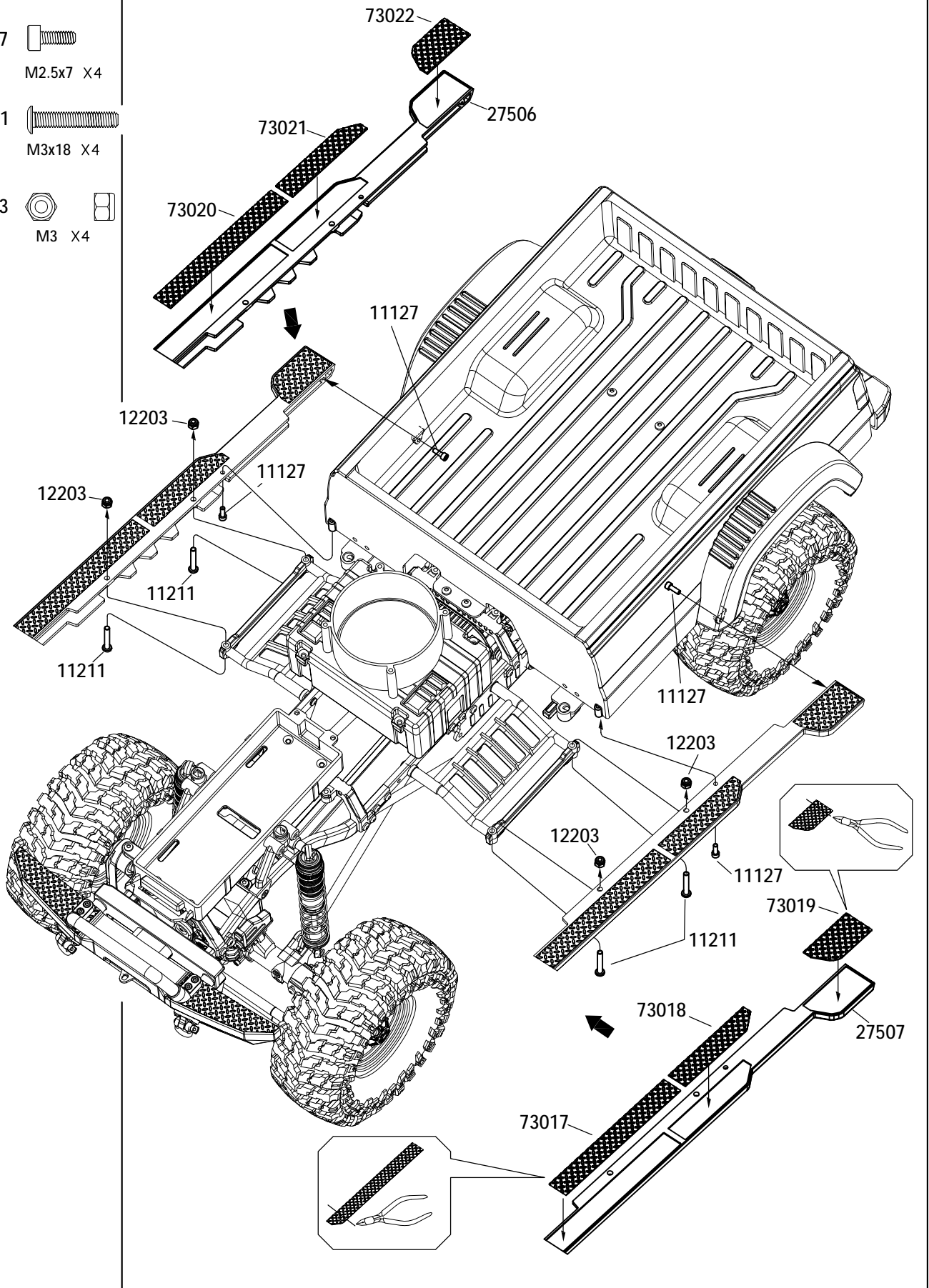

51

Correct position

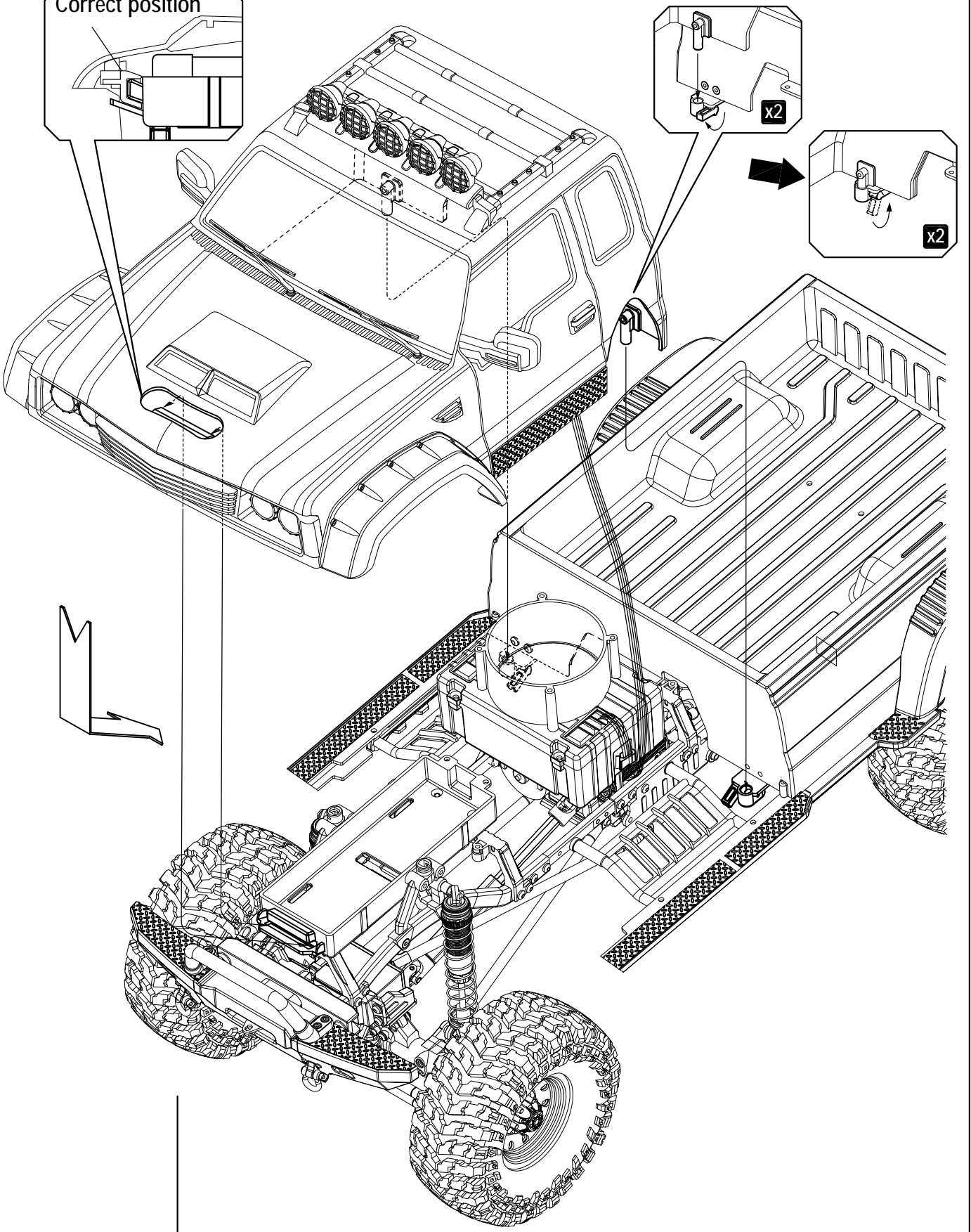

2-speed Transmission gear box instruction manual

Servo arm installation

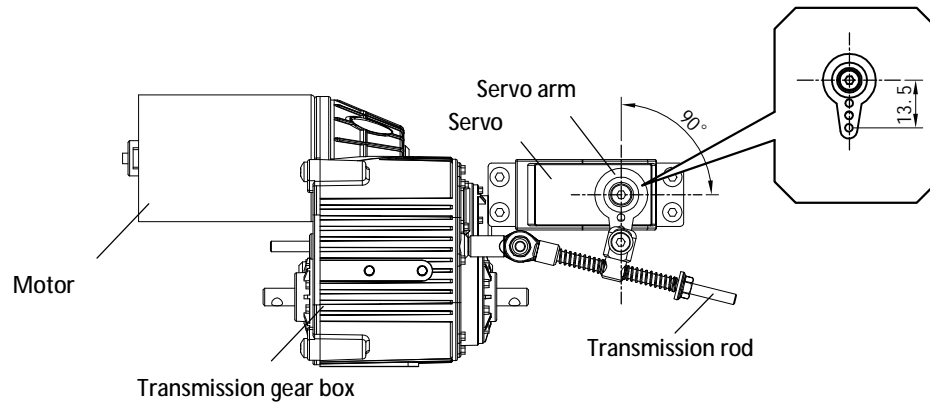

1. 1 Check to remote control's instruction for get servo using and setting method.
- 1.2 Make sure the servo is in neutral position before installation, as shown in the drawing to keep the transmission rod in its state (low gear), the arm is mounted on the servo, and the servo doesn't put pressure on the shift rod after installation completed

Servo stroke adjustment

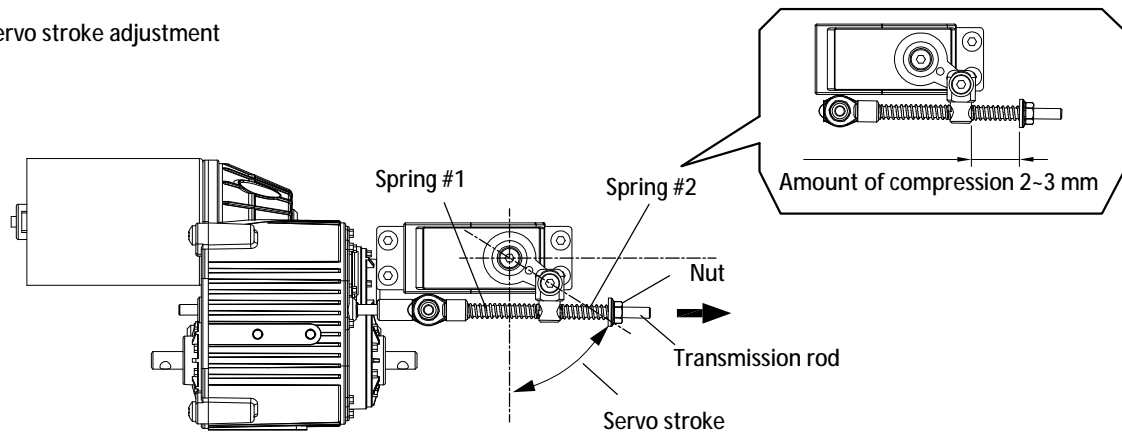

2. Adjusting servo stroke and result to spring decrement in the 2-3mm after into high speed gear.



WARNING

Make sure the servo is operated in a suitable stroke, it's may result in damage to the servo or transmission gearbox parts if the servo or shift rod continues to exert a large force.