

MC8(B/C)-越野卡车

(安装说明书)

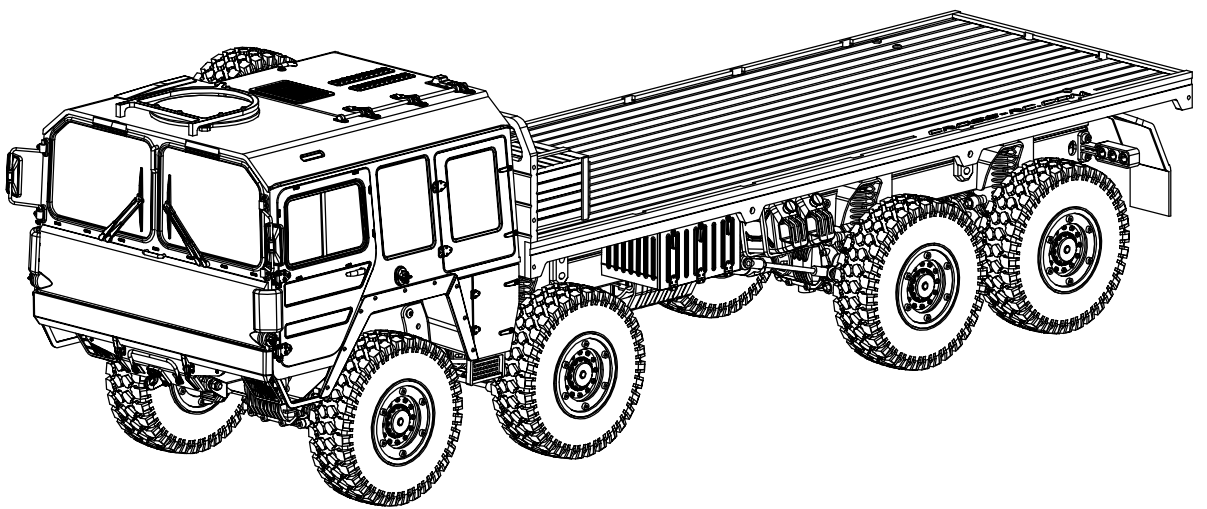
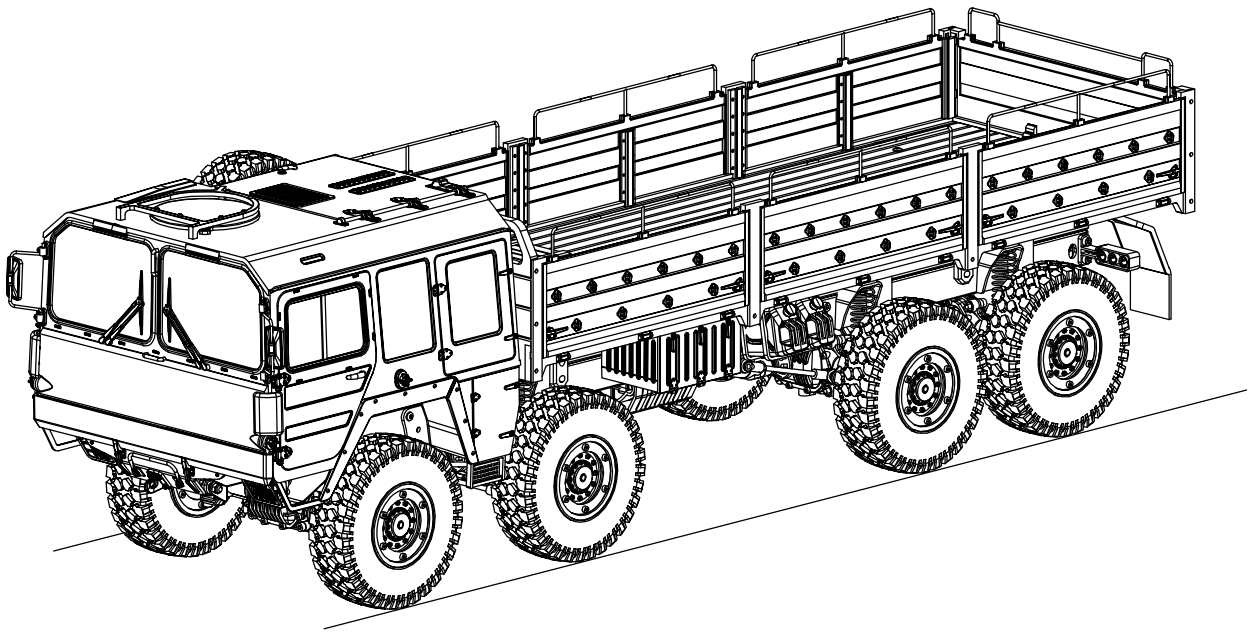

封面另行设计

CAUTIONS



To prevent serious personal injury and/or property damage, operate all remotely controlled models in a responsible manner as outlined herein.

◆ **Safety Precautions**

- 1.1 Choose a right place to operate your RC model.
- 1.2 Do not operate your RC model on the street or highway. It can cause a serious damage or a serious accident.
- 1.3 Never operate your RC model near people or animals.
- 1.4 Do not operate RC model in public places like hospital and residential areas.
- 1.5 Never operate RC model indoors. There is a higher possibility of fire or damage.
- 1.6 Keep the parts out of reach of children, small parts can cause choking and vinyl bags can suffocate.
- 1.7 Do not use with children younger than 14 years.

◆ **Inspect your RC model before operation**

- 2.1 Make sure that all screws and nuts are properly tightened. It is also a good idea to use removable thread lock wherever metal screws go into metal, especially for engine mounts and the engine pilot shaft.
- 2.2 Always use fresh batteries for your transmitter and for your receiver to avoid losing control of the model.
- 2.3 Always test the brakes and throttle before starting your engine to avoid losing control of the model.
- 2.4 Always turn on the transmitter first, and then turn on the receiver.

◆ **After operation of your RC model**

- 3.1 Turn off receiver first, then turn off transmitter, this will prevent runaways.
- 3.2 Be careful when handling batteries, they will be hot after running.
- 3.3 Replace any batteries that have been dented or have frayed wires, short circuits can cause fire.

TOOLS

(Not included)

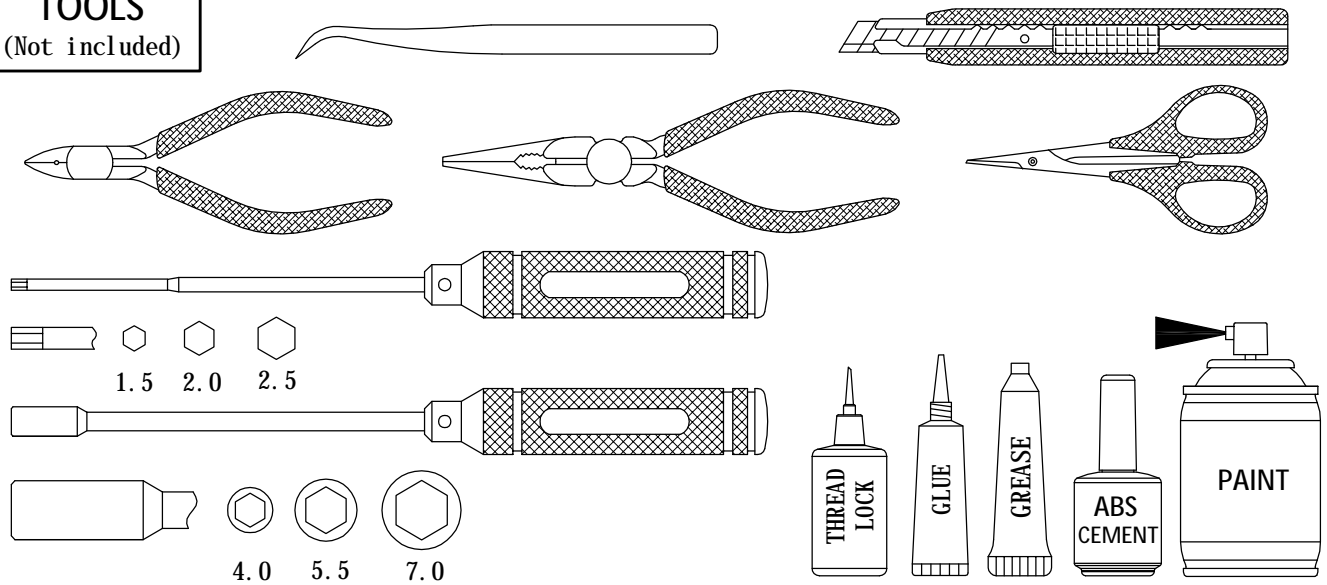

Electronic equipment

(Not included)

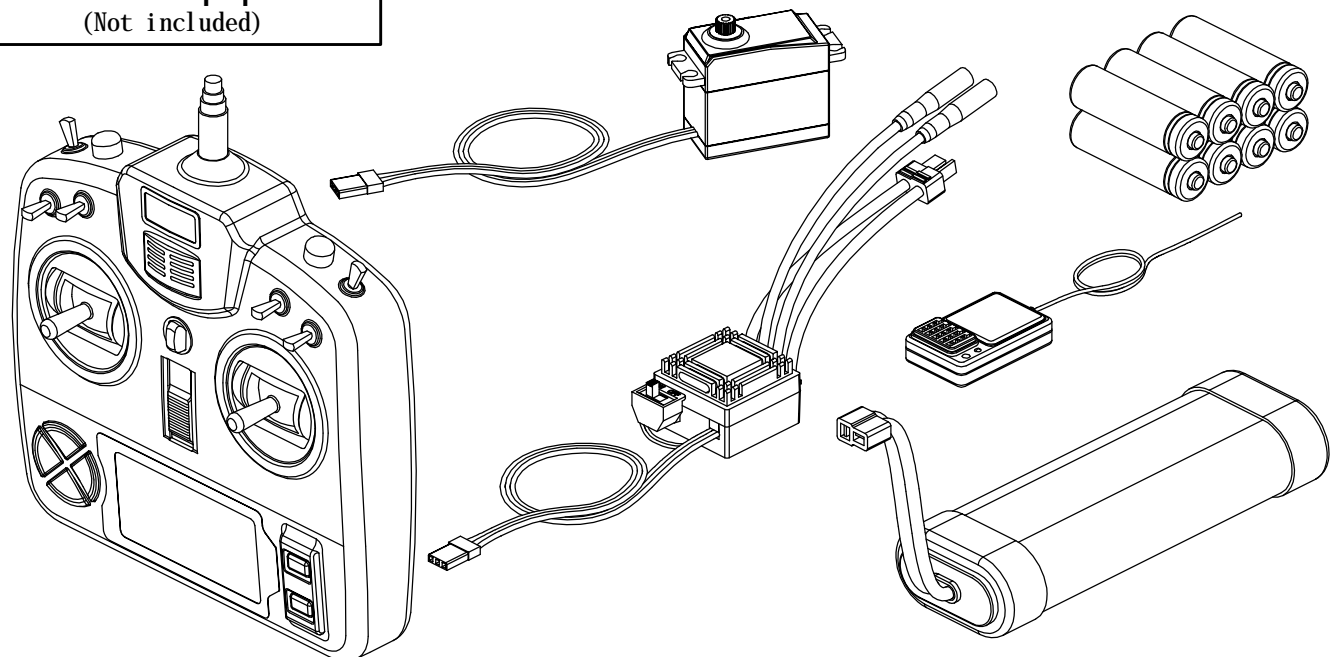

Lighting System

MC8B/C

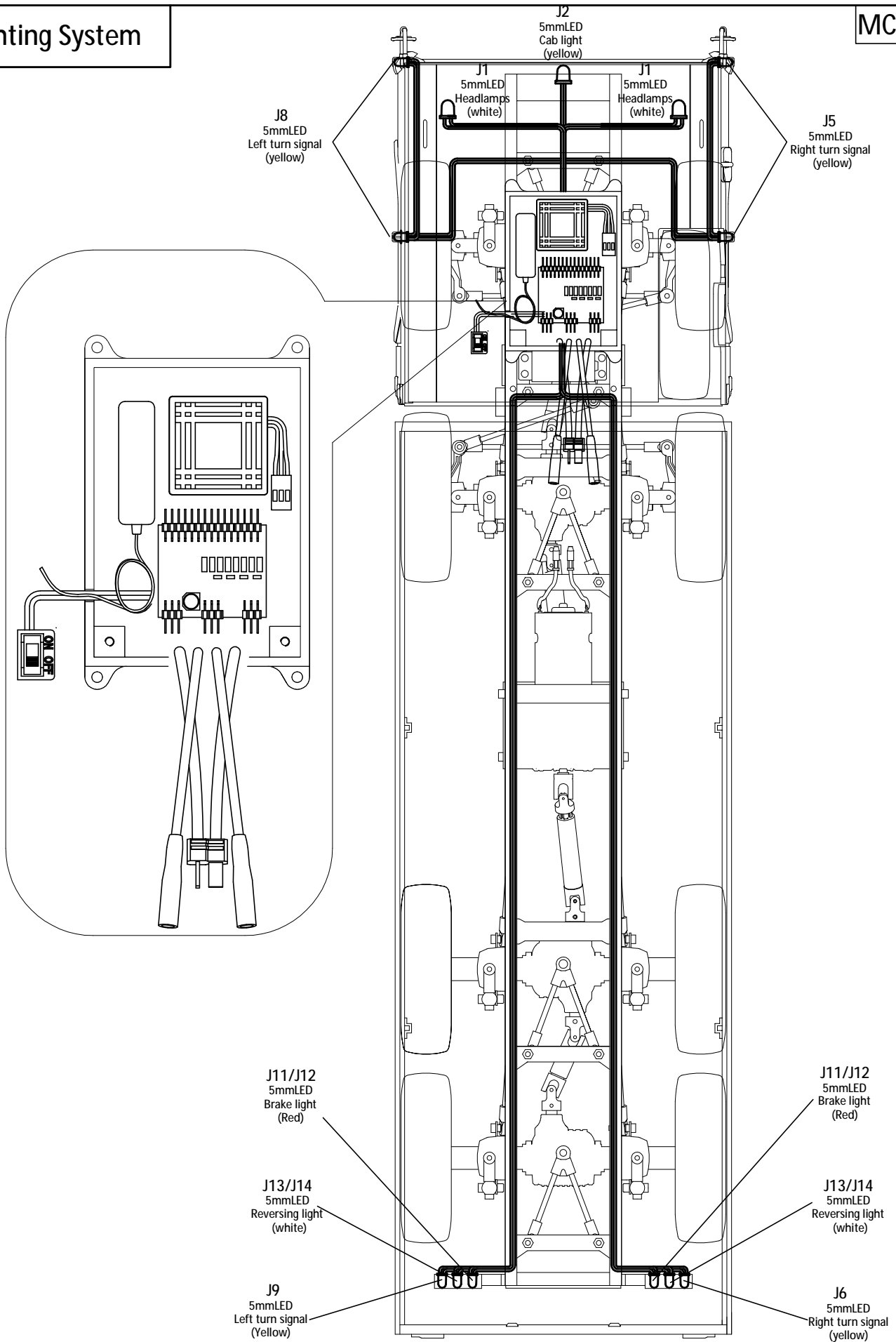

PLANK

MC8B/C

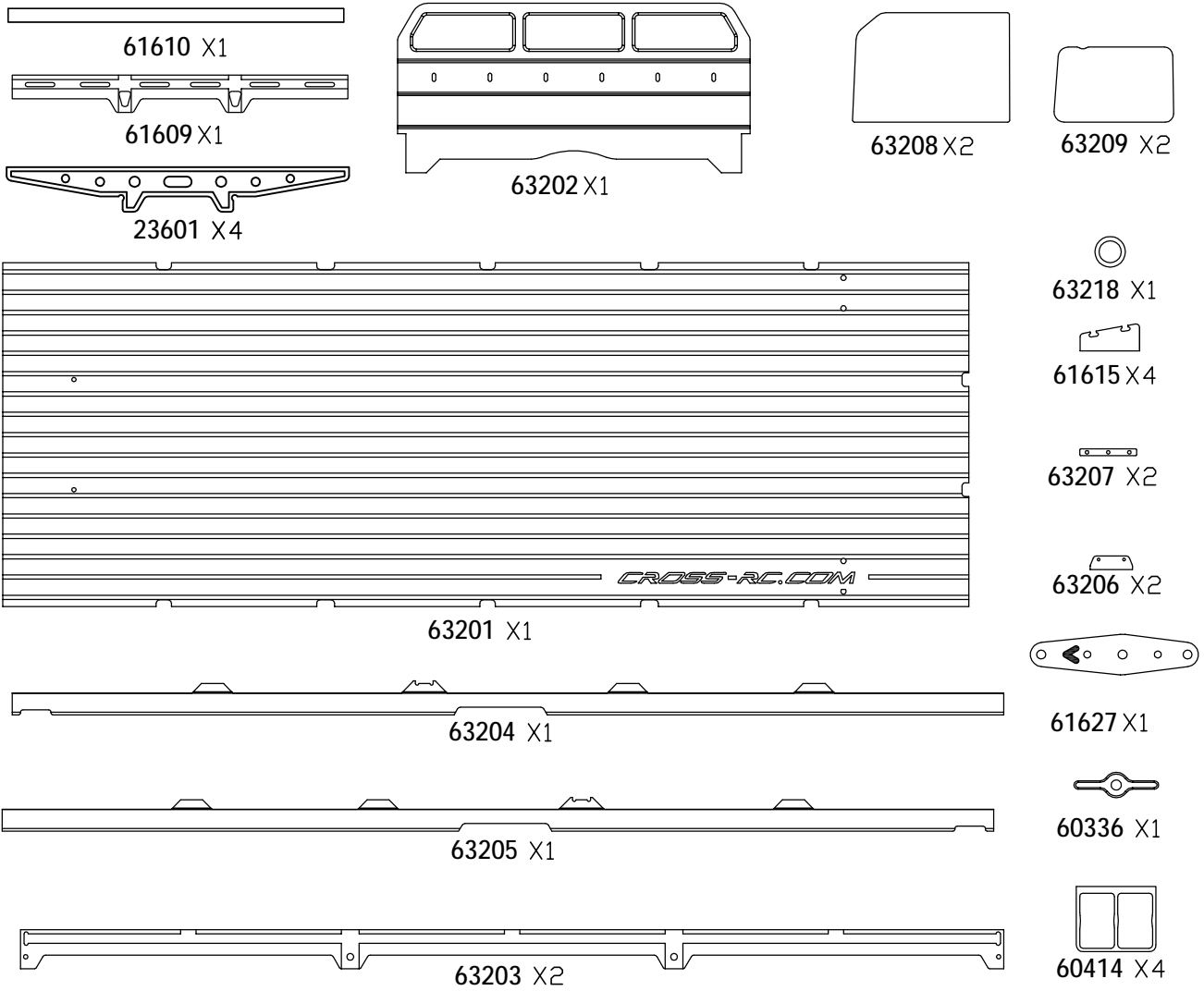

Frame

MC8B/C

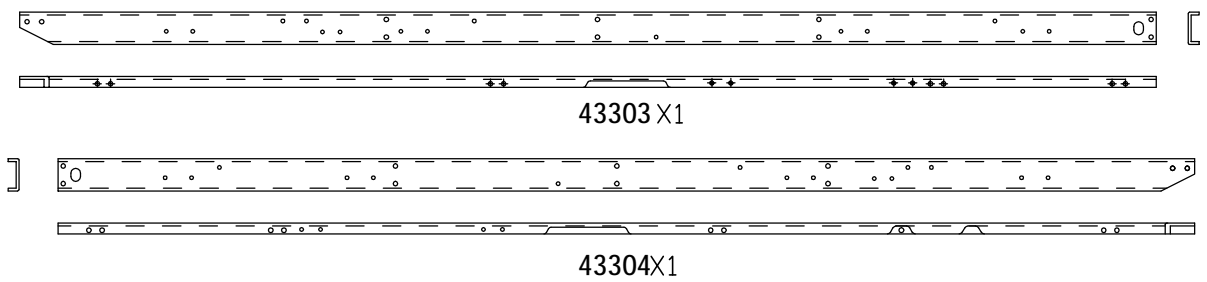

WHEELS AND TIRES

MC8B/C

11102  M2x6 X12

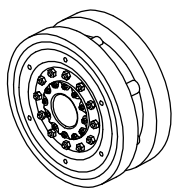

20001 X1

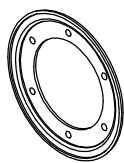

71000 X2

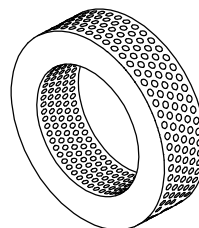

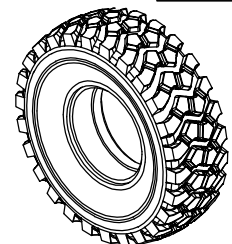

42302 X9



50009 X9

MC8B/C

12102  11118  11103 
 M2 X80 M2x16 X4 M2x8 X80

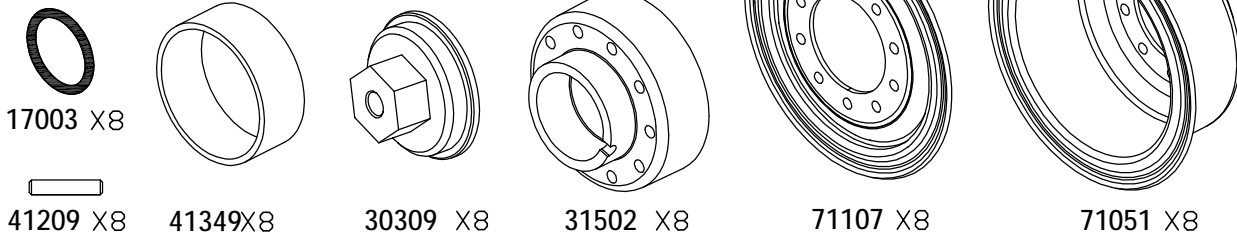

TRANSMISSION GEAR BOX

MC8B/C

11303 
 M3x8 X4

11401 
 M3x4 X1

11102 
 M2x6 X2

11106 
 M3x8 X2

11219 
 M3x4 X3

11207 
 M3x10 X4

14102 
 $\phi 3 \times \phi 7 \times 0.5$ X2

13003 
 $\phi 2.5 \times \phi 6 \times 0.4$ X2

13002 
 $\phi 3.8 \times \phi 9.2 \times 0.6$ X10

15003 
 $\phi 5 \times \phi 10 \times 4$ X12

72003 
 $\phi 5 \times \phi 8 \times 0.5$ X2

72007 
 $\phi 5 \times \phi 8 \times 0.3$ X2

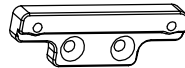

44016 X2

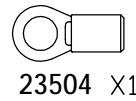

23504 X1

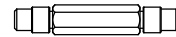

41289 X1



41290 X1

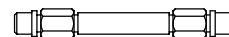

41291 X1



41263 X1

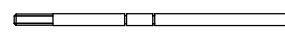

41129 X1



41307 X1

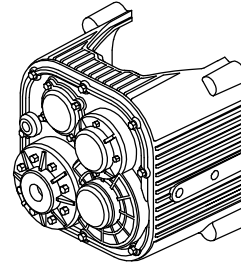

31401 X1

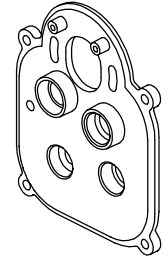

31402 X1

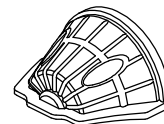

31403 X1



31405 X1

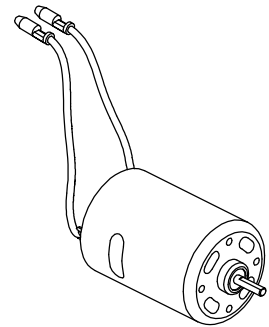

45T X1

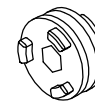

41344 X1

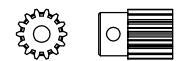

41303(14T) X1

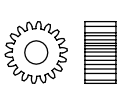

41338 X1

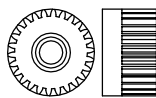

41339 X1

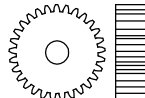

41340 X1

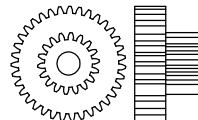

41341 X1

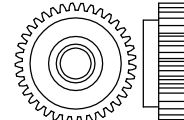

41342 X1

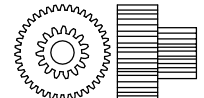

41343 X1

11209 
 M3x14 X1

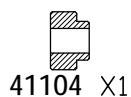

41104 X1

11211 
 M3x18 X1

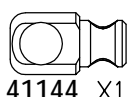

41144 X1

12203 
 M3 X2



41145 X1

12303 
 M3 X1

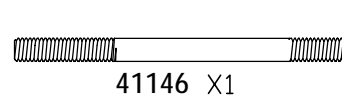

41146 X1

23502 X1

41336 X1

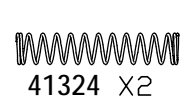

41324 X2

AXLES



15003 $\phi 5x\phi 10x4$ X24



15004 $\phi 10x\phi 15x4$ X12



13004 $\phi 2x\phi 5.5x0.4$ X6



13002 $\phi 4x\phi 9x0.6$ X10

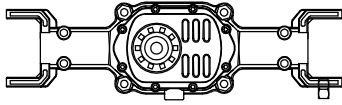

20107 X2

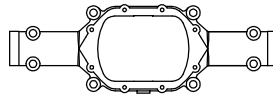

20101 X2

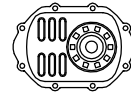

20106 X2

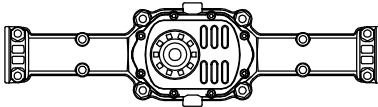

20103 X2

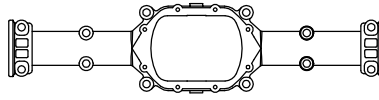

20104 X2

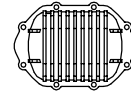

20105 X2

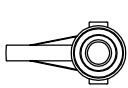

20102 X4

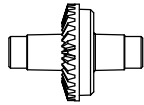

31701 X4

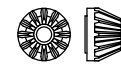

31702 X6

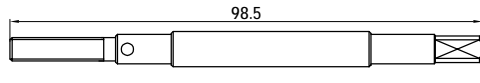

41232 X4



41205 X8



41209 X6



41210 X6

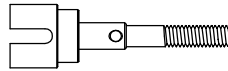

41230 X4

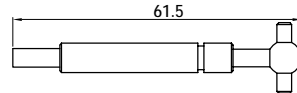

41203 X4



72007 $\phi 5x\phi 8x0.3$ X6

72003 $\phi 5x\phi 8x0.5$ X6

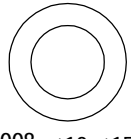

72008 $\phi 10x\phi 15x0.2$ X8

72009 $\phi 10x\phi 15x0.3$ X8

72010 $\phi 10x\phi 15x0.5$ X8

optional



12203 M3 X28

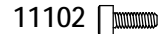

11102 M2x6 X32



11107 M3x10 X8



11601 M3x16 X4



11108 M3x12 X24

AXLES



15003 $\phi 5x\phi 10x4$ X24



15004 $\phi 10x\phi 15x4$ X12



13004 $\phi 2x\phi 5.5x0.4$ X6



13002 $\phi 4x\phi 9x0.6$ X10

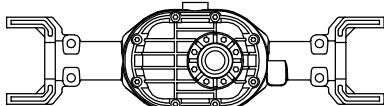

30601 X2

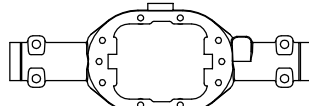

30602 X2

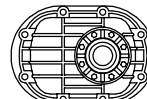

30603 X2

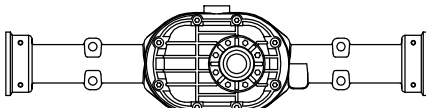

30701 X2

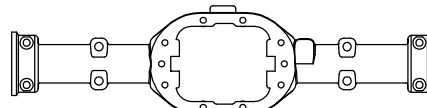

30702 X2

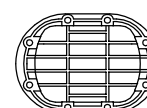

30703 X2



30704 X4

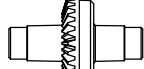

31701 X4



31702 X6

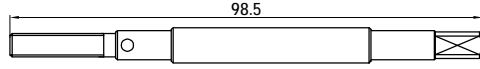

41232 X4



41205 X8



41209 X6

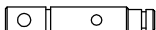

41210 X6

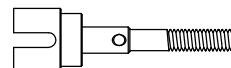

41230 X4

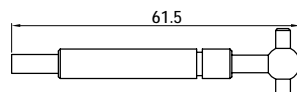

41203 X4



11405 M4x4 X4



72007 $\phi 5x\phi 8x0.3$ X6

72003 $\phi 5x\phi 8x0.5$ X6

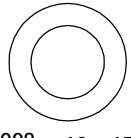

72008 $\phi 10x\phi 15x0.2$ X8

72009 $\phi 10x\phi 15x0.3$ X8

72010 $\phi 10x\phi 15x0.5$ X8

optional



12203 M3 X4



11125 M2.5x10 X8



11207 M3x10 X8



11601 M3x16 X4

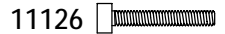

11126 M2x14 X32

SUSPENSION SYSTEM

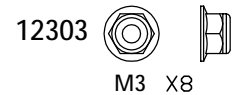
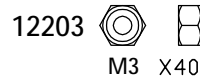
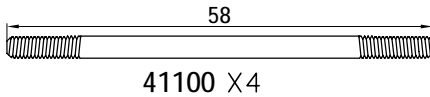
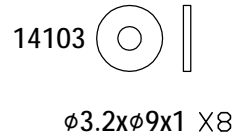
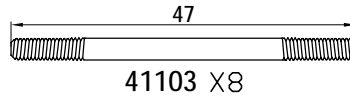
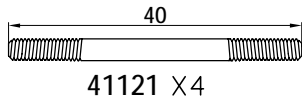
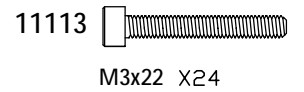
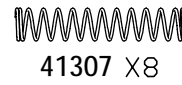
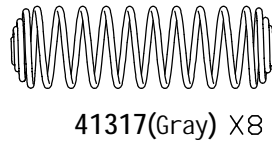
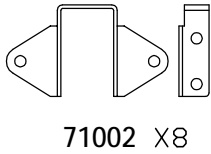
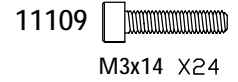
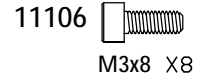
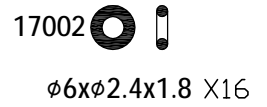
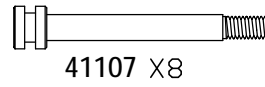
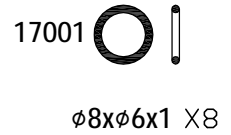
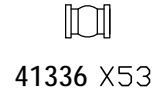
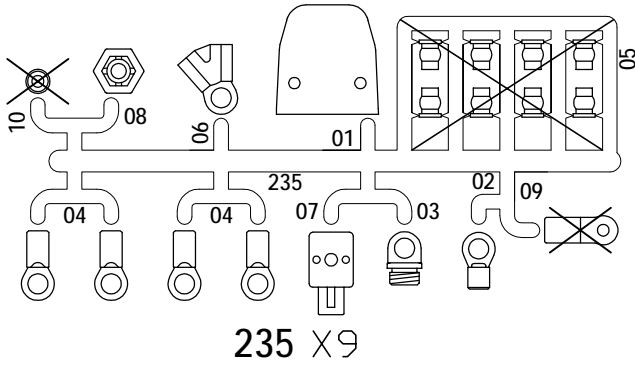

MC8B





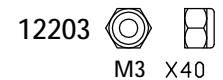
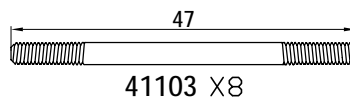
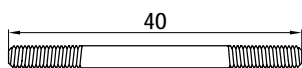
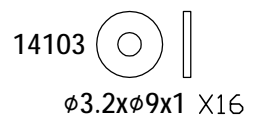
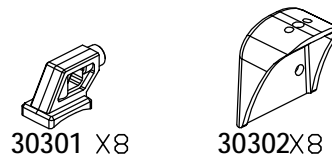
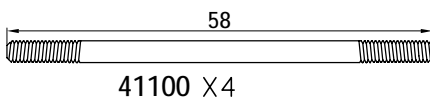
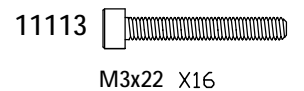
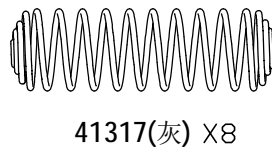
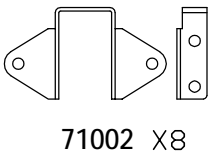
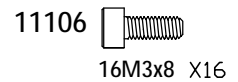
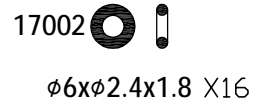
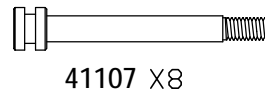
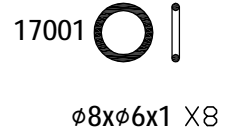
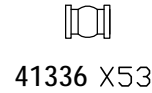
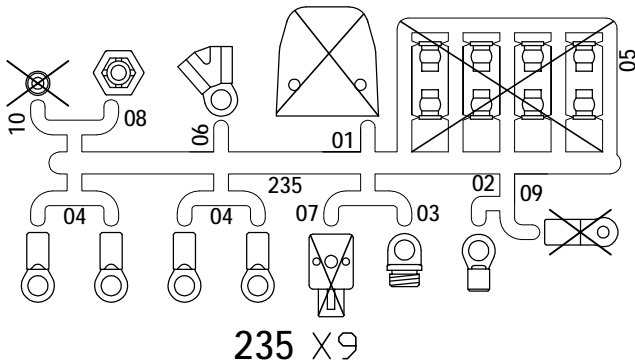

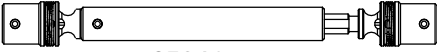
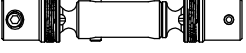
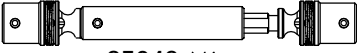

SUSPENSION SYSTEM

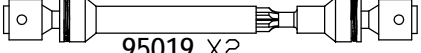
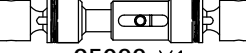
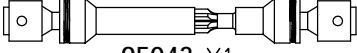



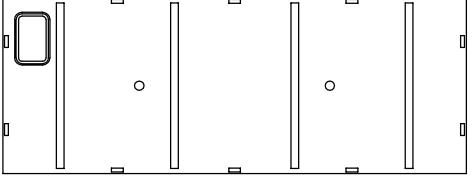
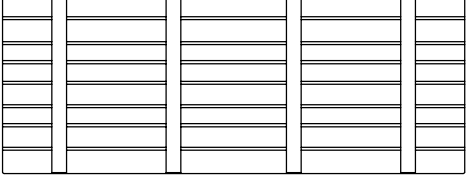

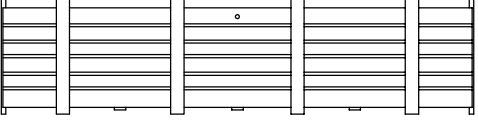
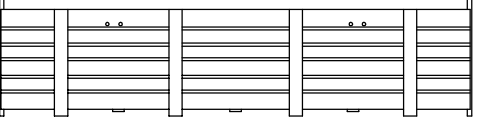

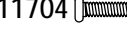
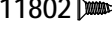

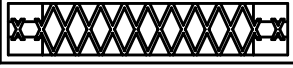
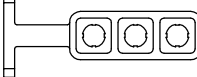

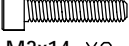
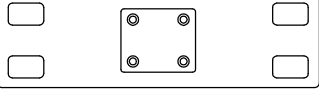
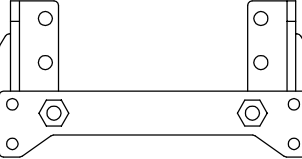

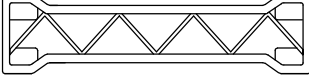
MC8C



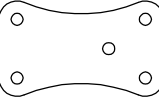
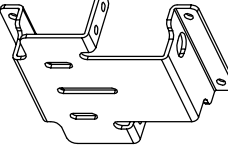

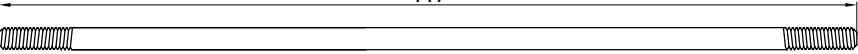
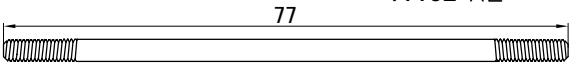
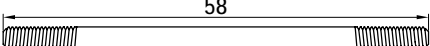

| | | | |
|---------------------|---|--|--|
| DRIVE SHAFTS |  95041 X2 |  95034 X1 | MC8B |
| |  95042 X1 | | 11409  M3x10 X8 |

| | | | |
|---------------------|---|--|--|
| DRIVE SHAFTS |  95019 X2 |  95022 X1 | MC8C |
| |  95043 X1 | | 11402  M3x10 X8 |

| | | | |
|--|---|---|---------------|
| THE BATTERY BOX | | | MC8B/C |
|  28801 X1 |  28802 X1 |  28803 X2 | |
|  28804 X1 |  28805 X1 |   72019 X1 94013 X2 | |
| | |  M1.6x6 X2  ST1.4x4 X8 | |

| | | | |
|---|--|---|---|
| BAG(FA) | | | MC8B/C |
|  28702 X1 |  21906 X2 |  M3x8 X54 |  M3x14 X8 |
|  20602 X1 |  20601 X1 |  M3x18 X8 |  M3x22 X2 |
|  20604 X2 |  20606 X4 |  M3x35 X2 |  M3x6 X22 |
|   71001 X4 71007 X2 |  71074 X1 |  X6 |  M3x10 X21  M3x16 X2 |
|  M3 X26 |  $\phi 3 \times \phi 7 \times 0.5$ X4 | | |
|  117 41102 X2 |  77 41119 X1 |  58 41100 X1 | |



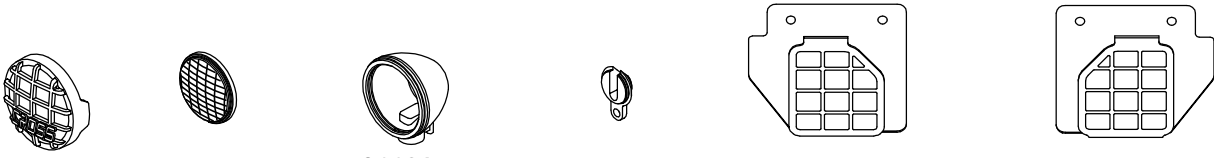

BAG(FB) **MC8B/C**

11102  M2x6 X2
 11501  ST2.6x6 X4
 11216  M2.5x6 X4
 12105  M2.5 X4
 11205  M3x6 X2

21100 X2 21200 X2 21106 X2 21110 X2 71016 X1 71017 X1





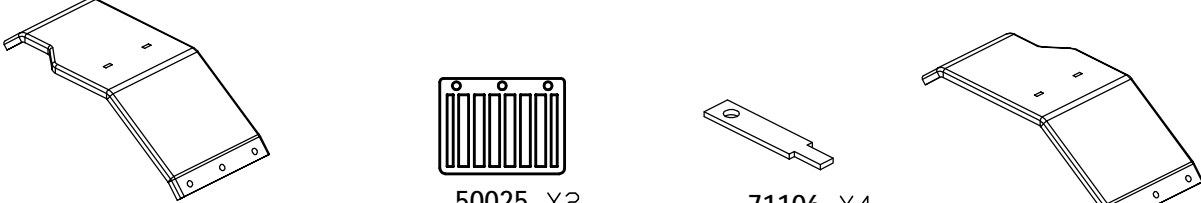

BAG(FC) **MC8B/C**

11102  M2x6 X4
 12001  M2x6 X6
 11207  M3x10 X4
 12203  M3 X4
 12102  M2 X6

71104 X1 50025 X2 71106 X4 71105 X1



BAG(FD) **MC8B/C**

11801  ST1.4x6 X16
 11802  ST1.4x4 X20
 11707  M1.6X10X4
 12106  M1.6 X4

27105 X2 27107 X2 24704 X4 71101 X2 73036 X2 72023 X4 72024 X4

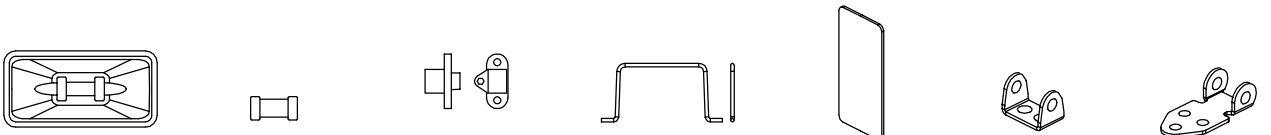









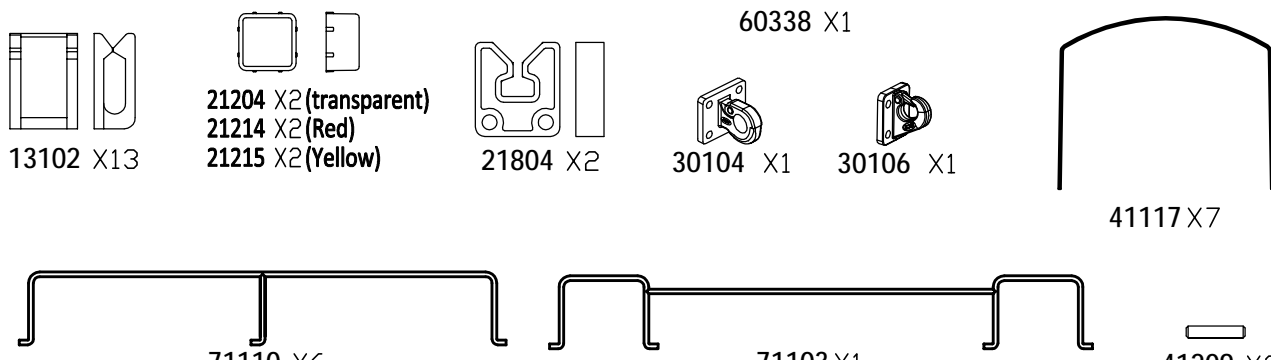











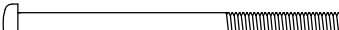

BAG(FE) **MC8B/C**

13102 X13 21204 X2 (transparent) 21214 X2 (Red) 21215 X2 (Yellow) 21804 X2 30104 X1 30106 X1 41117 X7

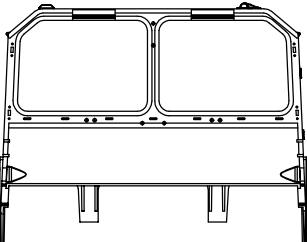
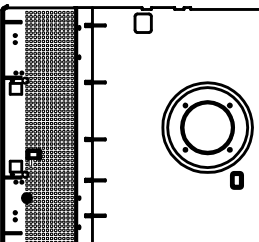
71110 X6 71103 X1 41209 X8

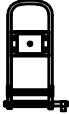
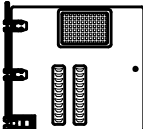
MAN
60338 X1

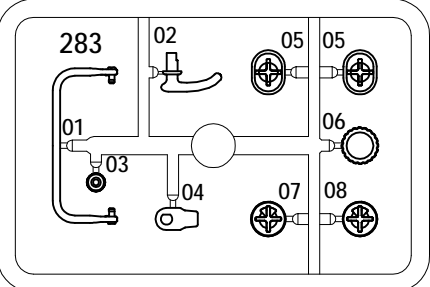
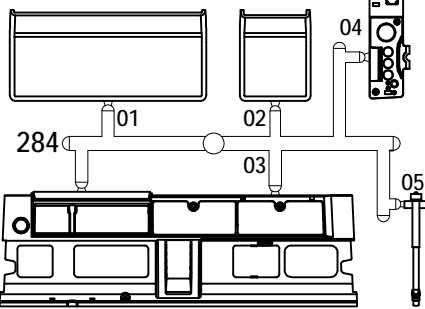
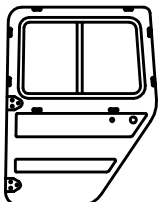
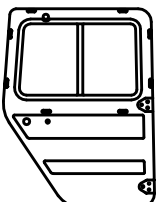
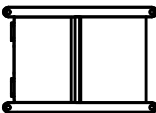

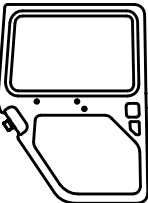
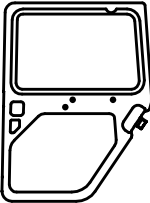
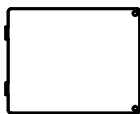
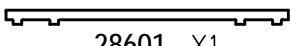
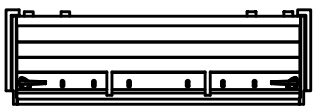
| | | | | |
|--|--|--|--|--|
| BAG(FF) | | MC8B/C | | |
| 11102  M2x6 X4 | 11109  M3x14 X2 | 11218  M2.5x4 X4 | 12002  M2x10 X4 | 14103  $\phi 3.2 \times \phi 9 \times 1$ X6 |
| 11106  M3x8 X4 | 11108  M3x12 X4 | 11216  M2.5x6 X17 | 11801  ST1.4x6 X1 | |
| 11107  M3x10 X4 | 11205  M3x6 X6 | 11207  M3x10 X2 | 12204  M X8 | |
| 11701  M3x45 X1 | | 12102  M2 X4 | 12203  M3 X1 | |
| No.281 | MC8B/C | No.282 | MC8B/C | |
|  28101 X1 | |  28205 X1 |  28202 X1 |  28201 X1 |
| | | |  28204 X1 |  28203 X1 |
| No.283 | MC8B/C | No.284 | MC8B/C | |
|  283 X1 | |  284 X1 | | |
| No.285 | MC8B/C | No.286 | MC8B/C | |
|  28501 X1 |  28502 X1 |  28604 X1 |  28603 X2 |  28602 X2 |
|  28503 X1 |  28504 X1 |  28605 X1 |  28601 X1 |  28606 X1 |

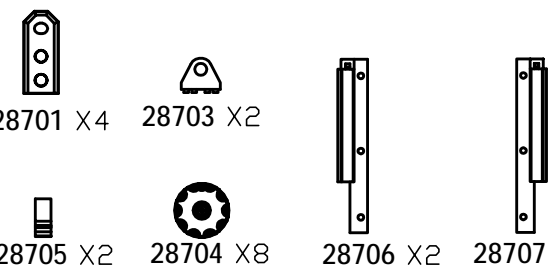
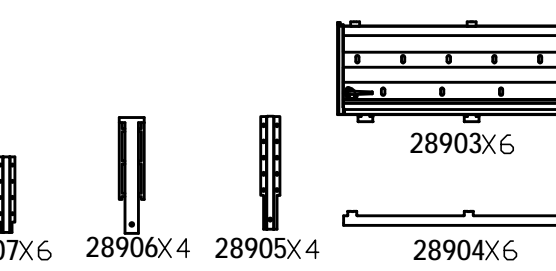

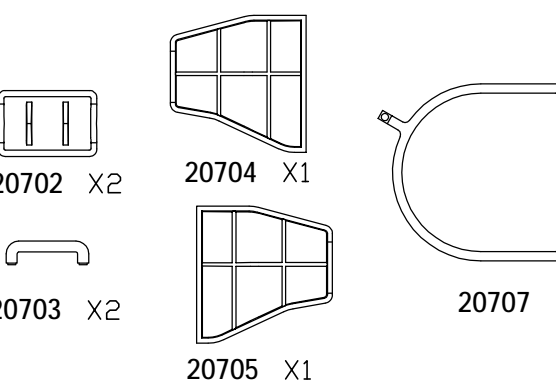
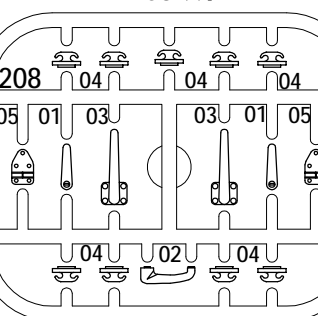

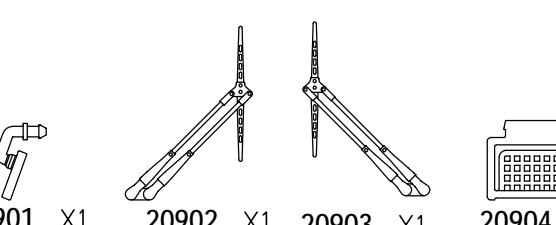
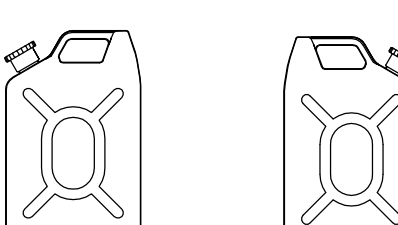

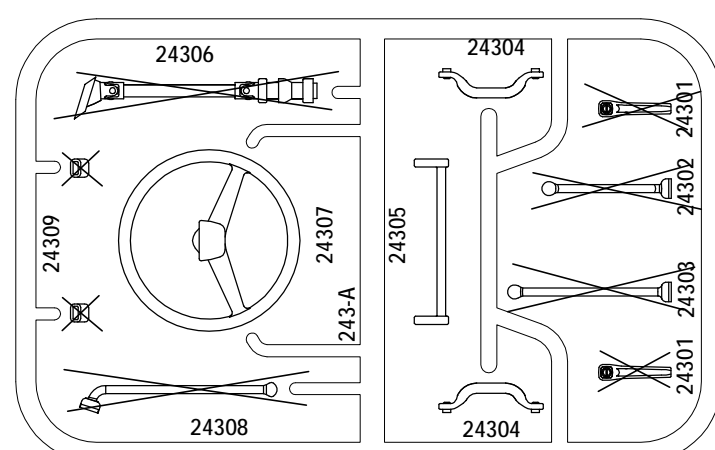
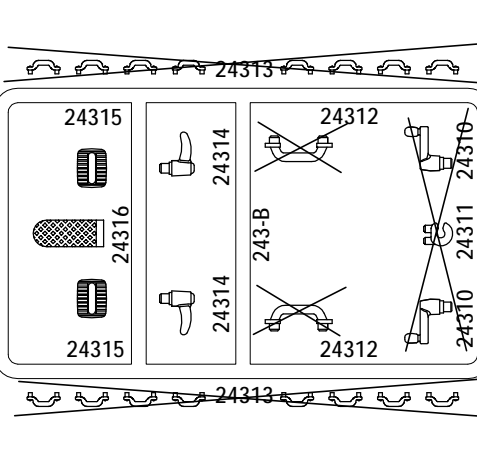
| | |
|--|---|
| <p>No.287</p>  <p>28701 X4 28703 X2</p> <p>28705 X2 28704 X8</p> <p>28706 X2 28707 X2</p> | <p>No.289</p>  <p>28907 X6 28906 X4 28905 X4</p> <p>28903 X6 28904 X6</p> |
|--|---|

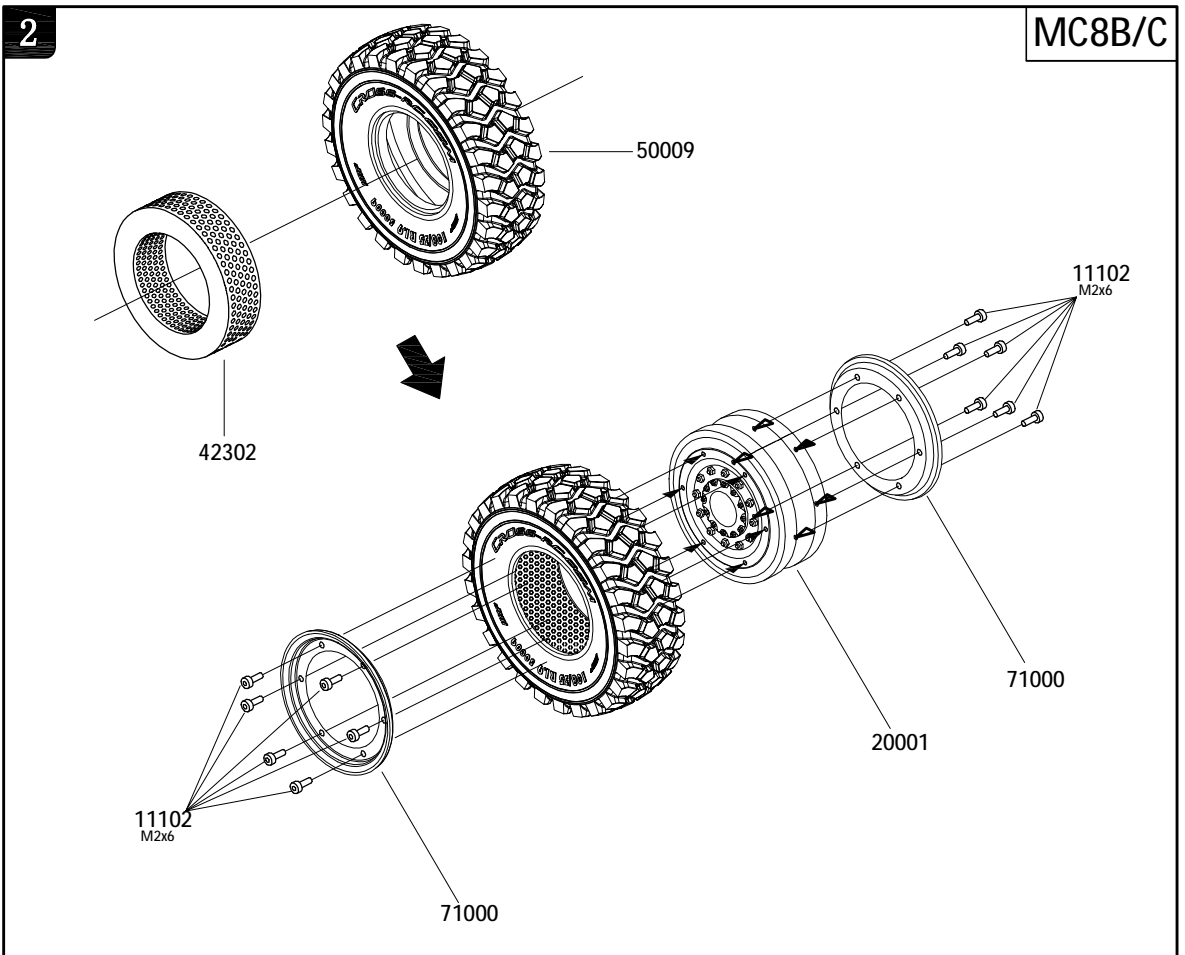
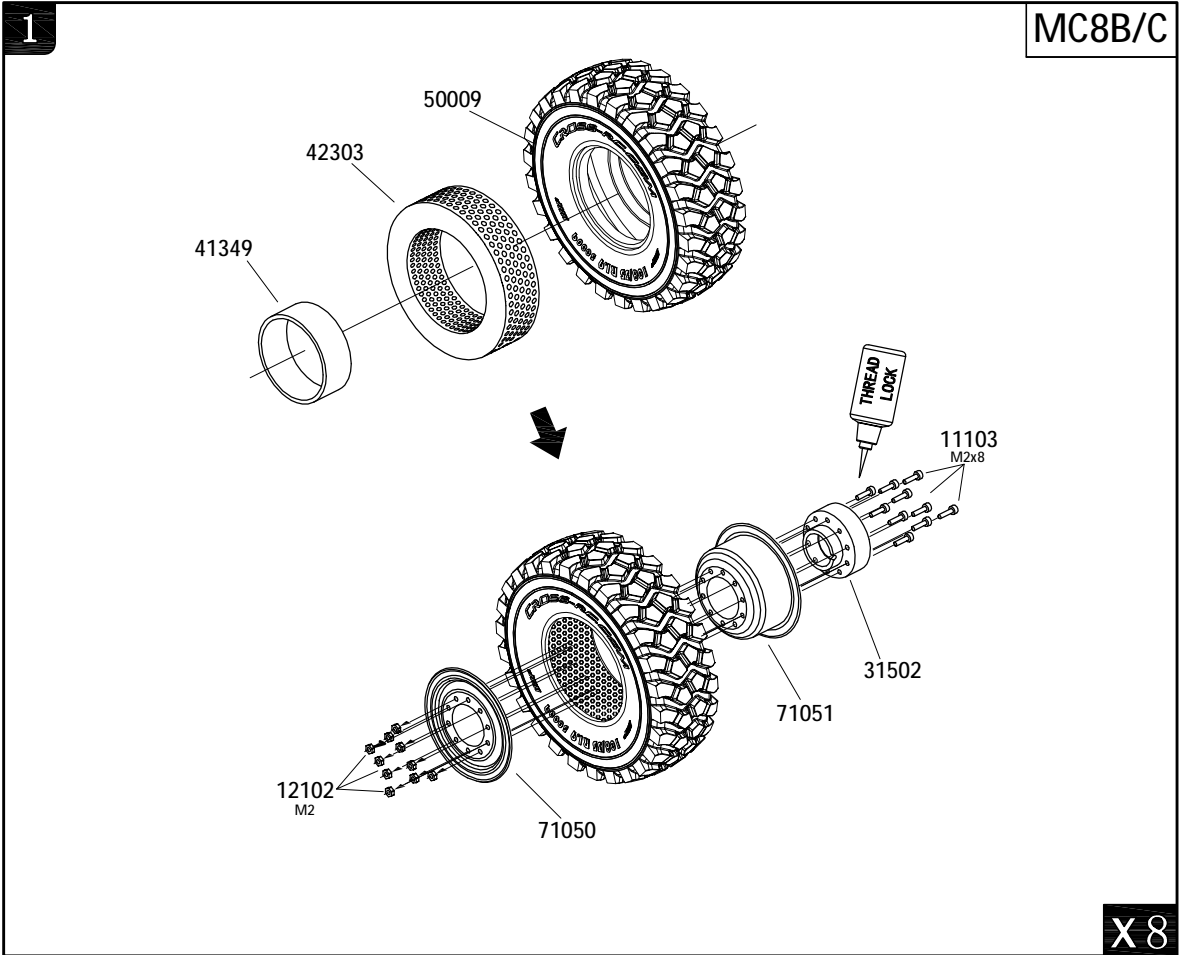
| | |
|---|--|
| <p>No.207</p>  <p>20702 X2</p> <p>20703 X2</p> <p>20704 X1</p> <p>20705 X1</p> <p>20707 X1</p> | <p>No.208</p>  <p>208 X9</p> |
|---|--|





| | |
|--|---|
| <p>No.209</p>  <p>20901 X1 20902 X1 20903 X1</p> <p>20904 X2</p> | <p>No.210</p>  <p>21017 X4 21019 X4</p> |
|--|---|

| | |
|---|---|
| <p>No.243</p>  <p>243 X1</p> <p>24306 24304</p> <p>24309 24307 243-A</p> <p>24308 24305</p> |  <p>24315 24316 24314 24312</p> <p>24313 24310 24311</p> |
|---|---|

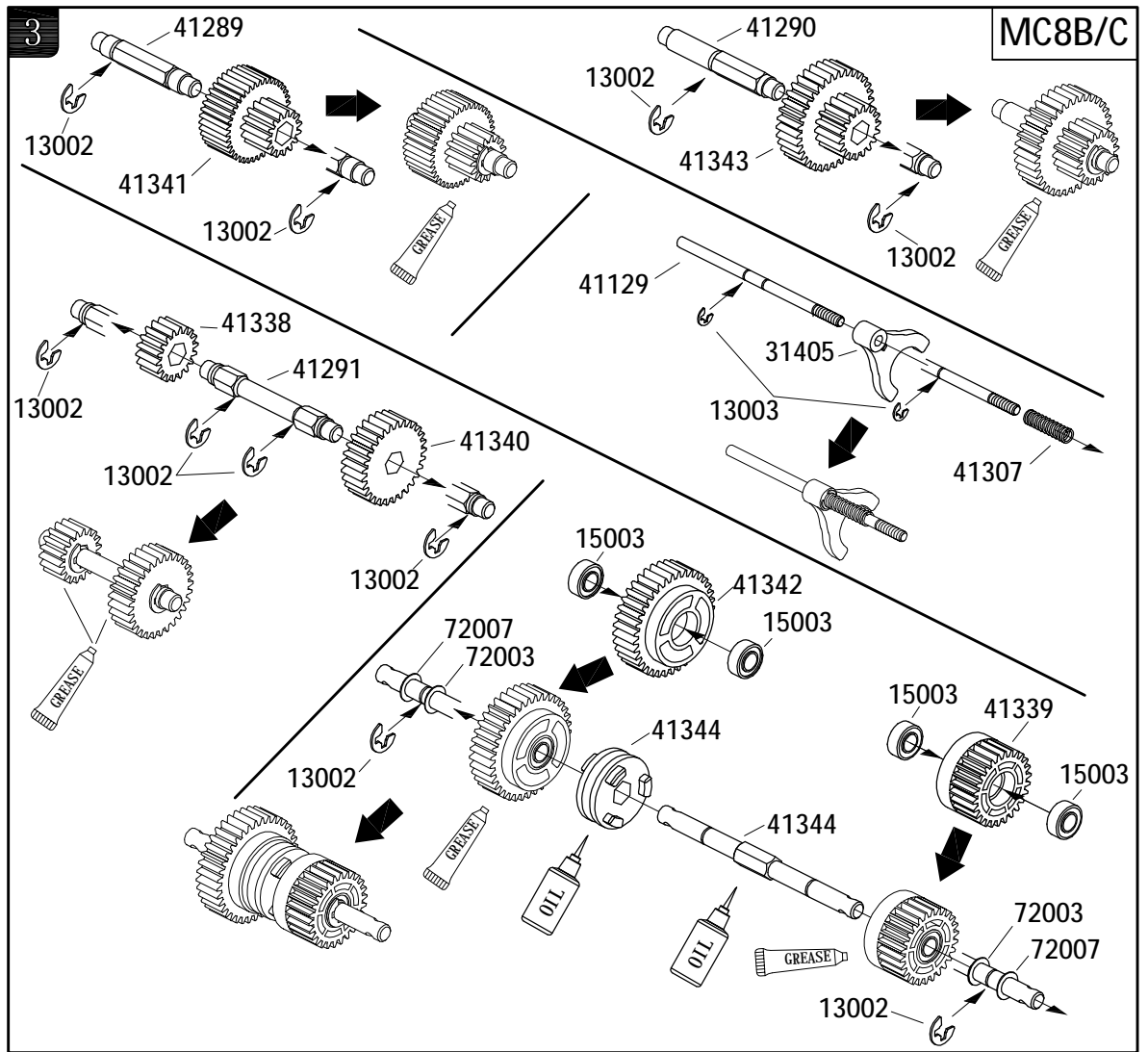

- 3
- 13002  $\phi 3.8 \times \phi 9.2 \times 0.6 \times 10$
 - 13003  $\phi 2.5 \times \phi 6 \times 0.4 \times 2$
 - 72007  $\phi 5 \times \phi 8 \times 0.3 \times 2$
 - 15003  $\phi 5 \times \phi 10 \times 4 \times 4$
 - 72003  $\phi 5 \times \phi 8 \times 0.5 \times 2$
- 



- 4
- 11219  M3x4 X3
 - 15003  $\phi 5 \times \phi 10 \times 4 \times 8$
 - 11207  M3x10 X4
- 

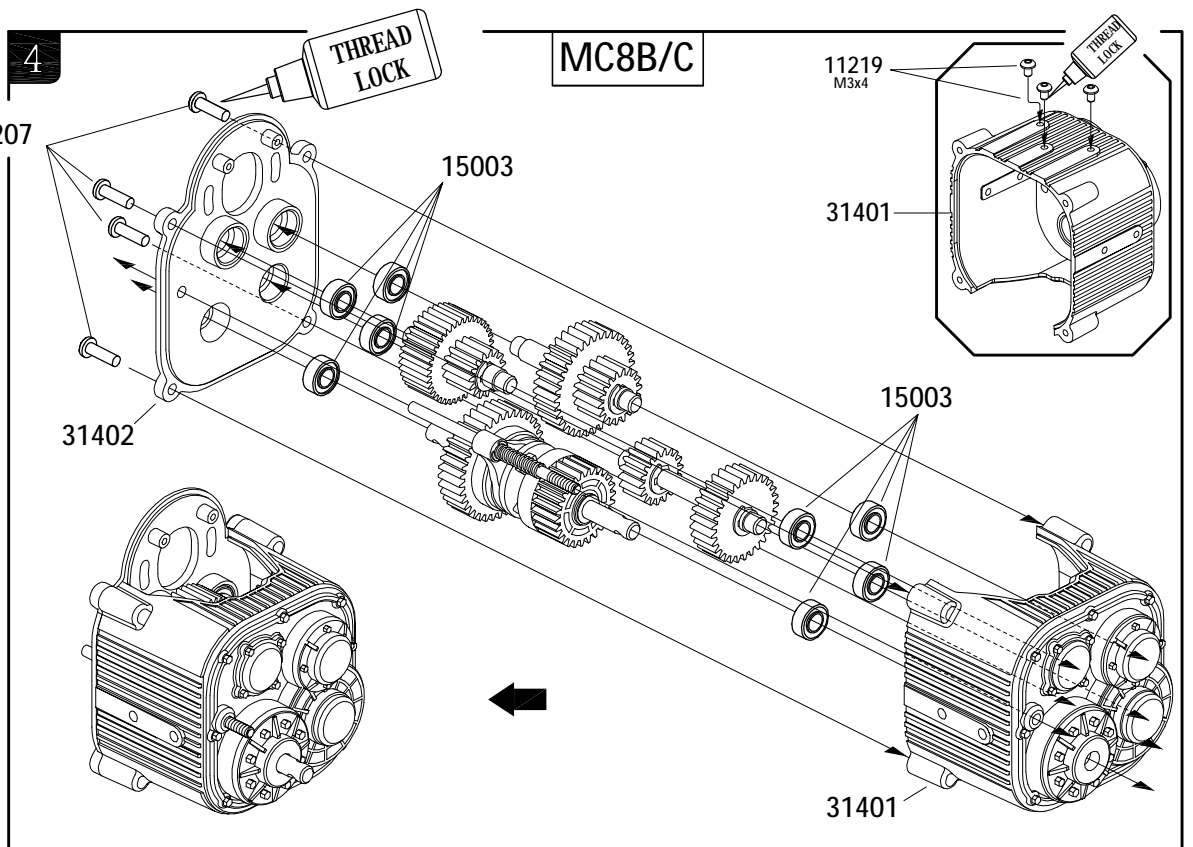

5 **MC8B/C**

Use a trip of the note book paper to set gear backlash between spur gear and moto gear.

Note book paper

11102 M2x6 X2
 11106 M3x8 X2
 11401 M3x4 X1
 14102 $\phi 3 \times \phi 7 \times 0.5$ X2

THREAD LOCK

0.5mm
Keep the clearance

11401

14102

11106

11102

20203

31403

THREAD LOCK

6 **MC8B/C**

12203 M3 X2
 12303 M3 X1
 11209 M3x14 X1
 11211 M3x18 X1

20201

41324

11209

41145

41144

41146

41324

12303

12203

41324

12203

41104

11211

7

MC8B/C

NOTE:

Get power test after assembly finish and adjust gear meshing clearance for make sure gear box running smooth without noise, then process to following assembly go on.

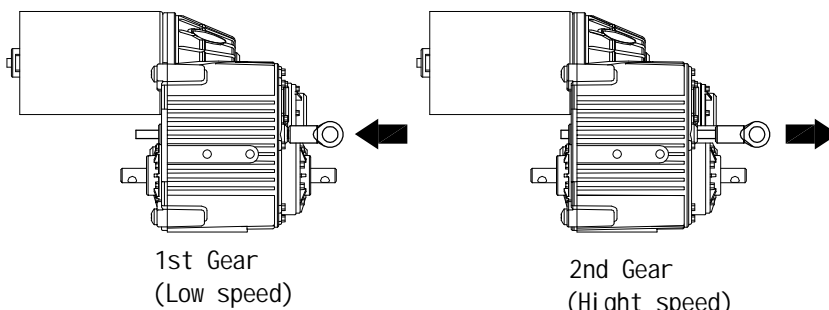
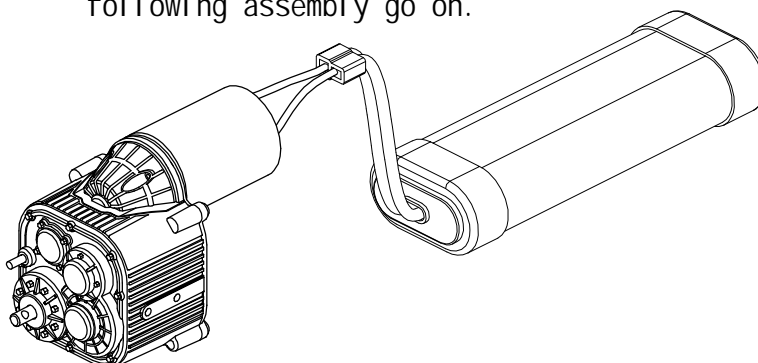

1st Gear
(Low speed)

2nd Gear
(High speed)

8

MC8B/C

11303  M3x8 X4

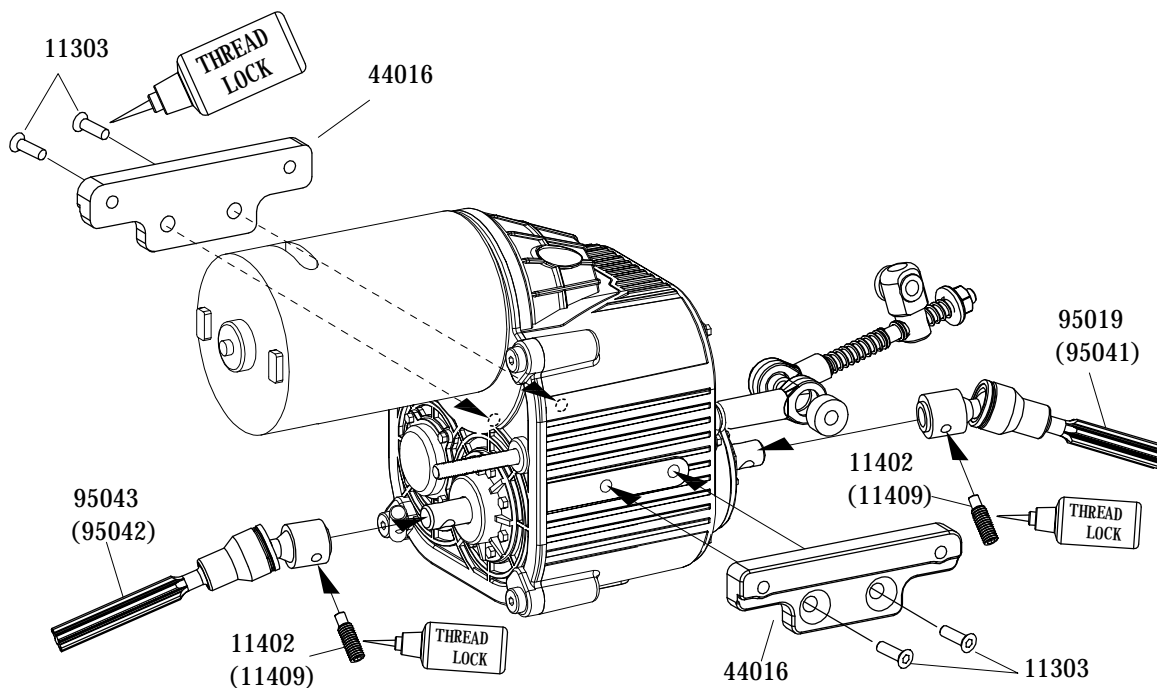

95041  X1

MC8B

95019  X1

MC8C

95042  X1

11409  M3x10 X2

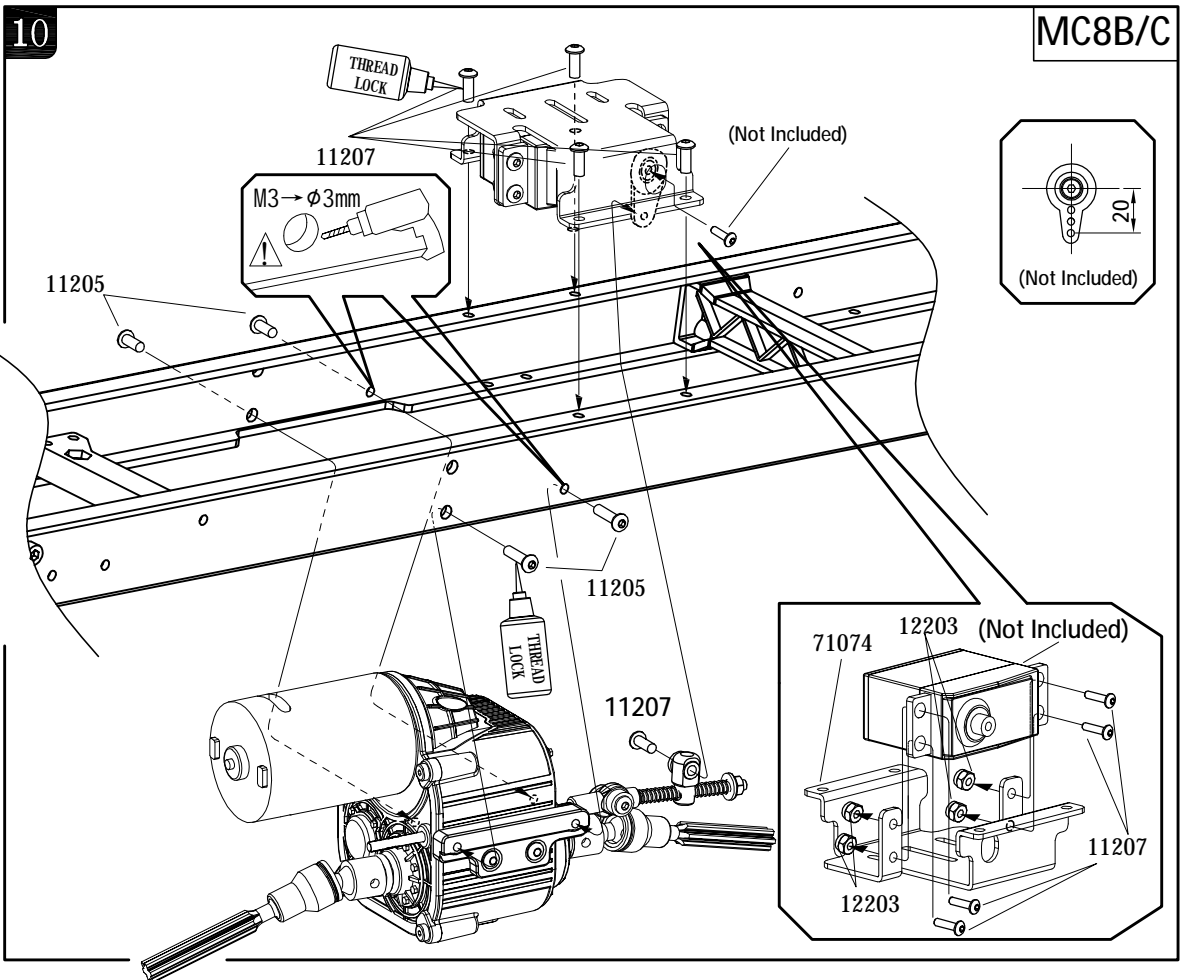
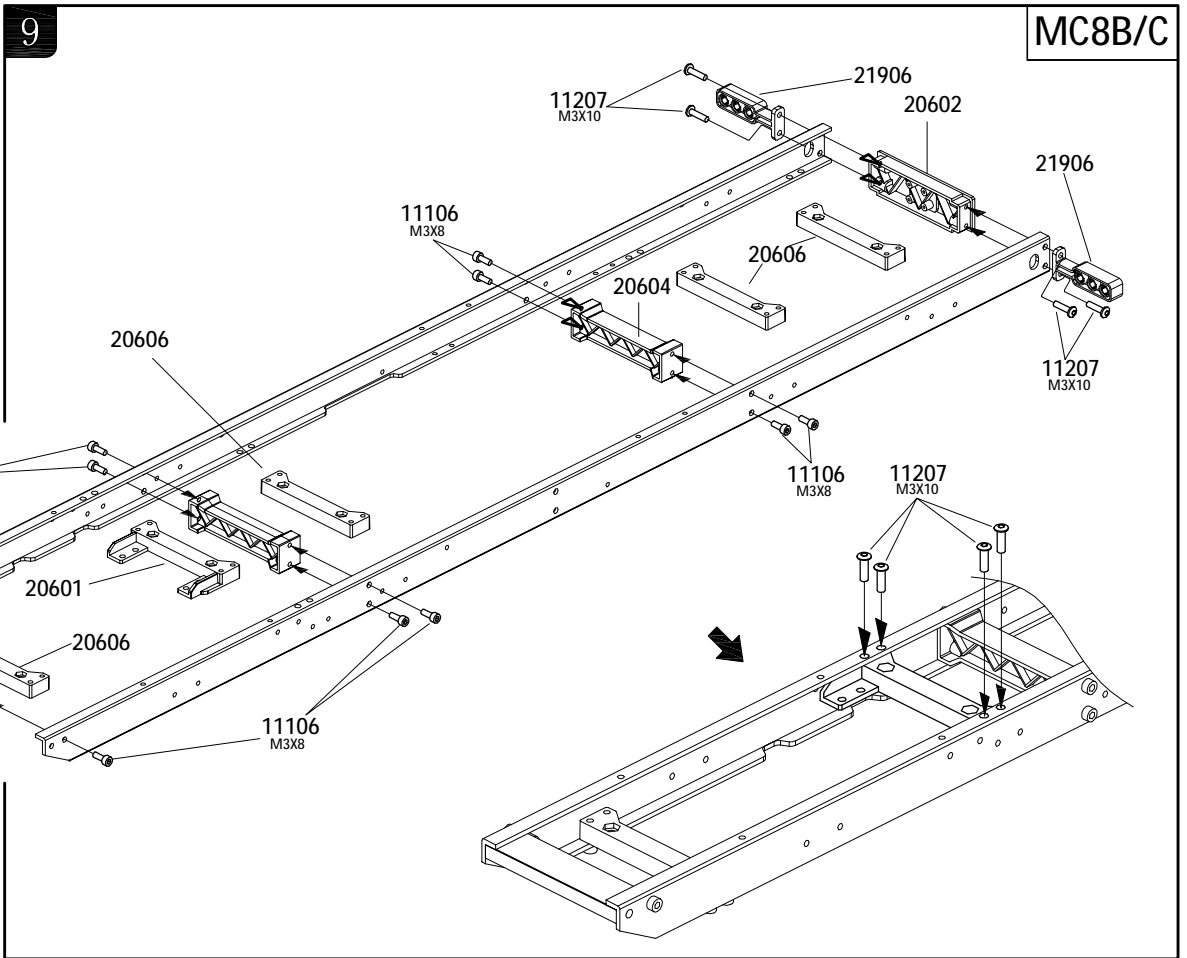

95043  X1

11402  M3x10 X2



11

MC8B/C

- 11205  M3x6 X4
- 11106  M3x8 X24

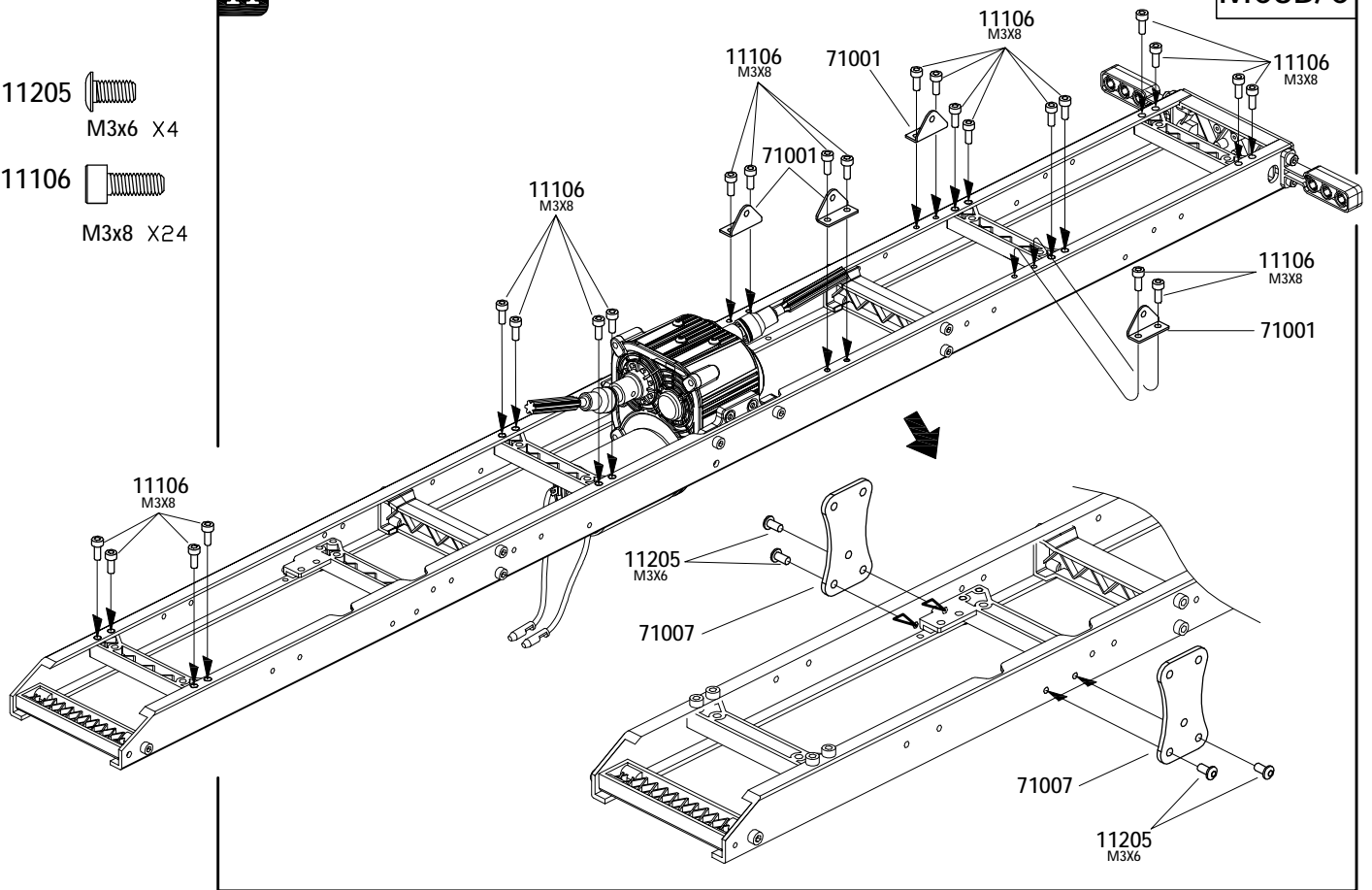

12

MC8B/C 13

MC8B/C

- 13004  $\phi 2 \times \phi 5.5 \times 0.4$ X6

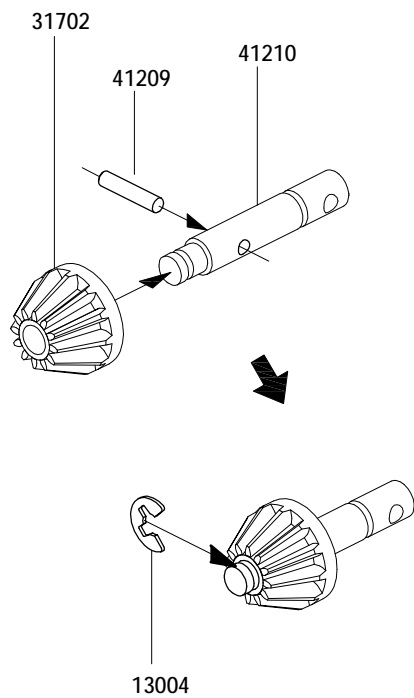

X6

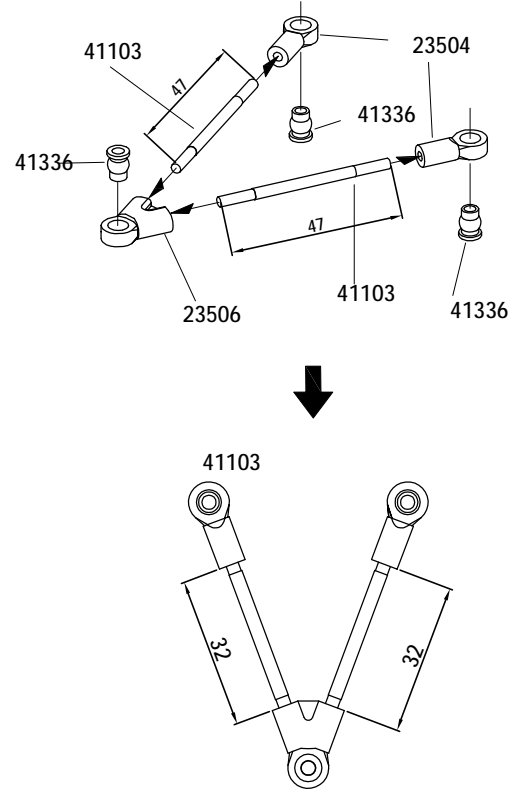

X4





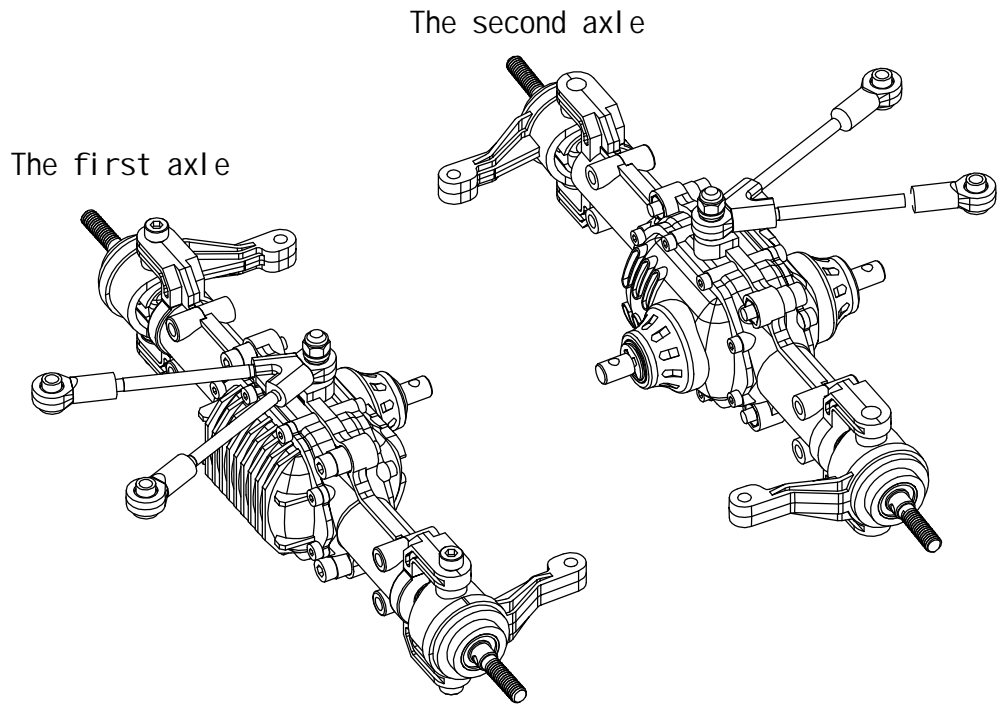



14

MC8B



15

MC8B



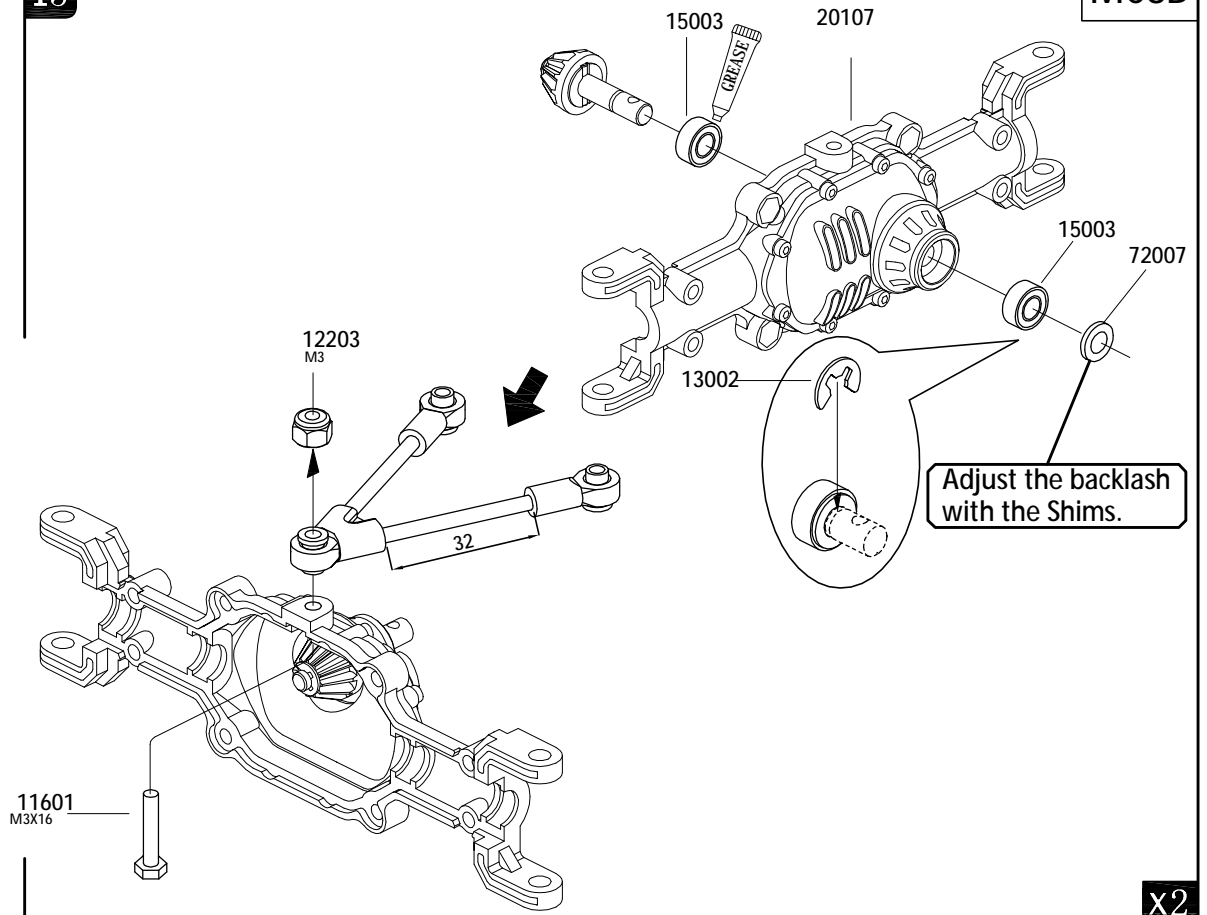



- 12203  
M3 X2
- 11601 
M3x16 X2
- 15003  
φ5xφ10x4 X4
- 13002  
φ4xφ9x0.6 X2
- 72007  
φ5xφ8x0.3 X2



X2

16

MC8B

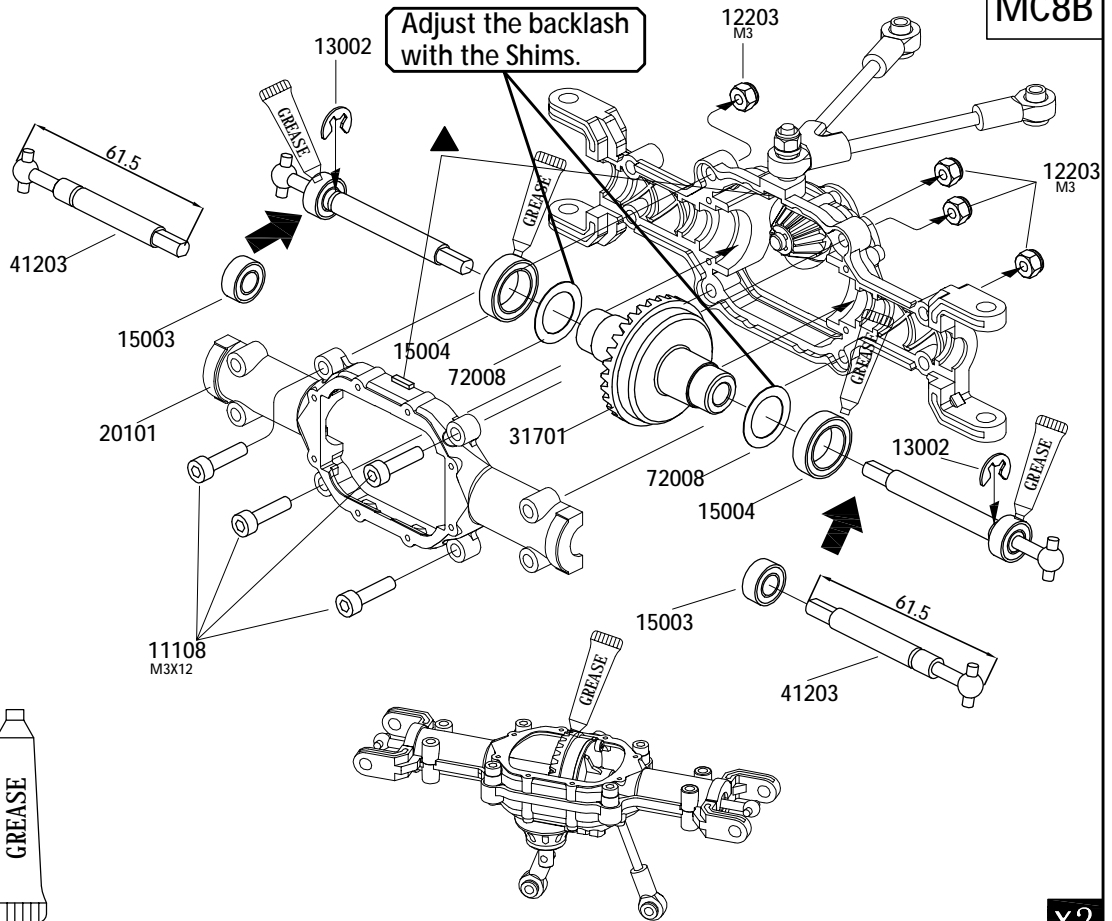

- 12203  M3 X8
- 11108  M3x12 X8
- 15003  $\phi 5x\phi 10x4$ X4
- 15004  $\phi 10x\phi 15x4$ X4
- 13002  $\phi 4x\phi 9x0.6$ X4
- 72008  $\phi 10.2x\phi 15x0.2$ X4



x2

17

MC8B

- 11107  M3x10 X8
- 15003  $\phi 5x\phi 10x4$ X4
- 15004  $\phi 10x\phi 15x4$ X4

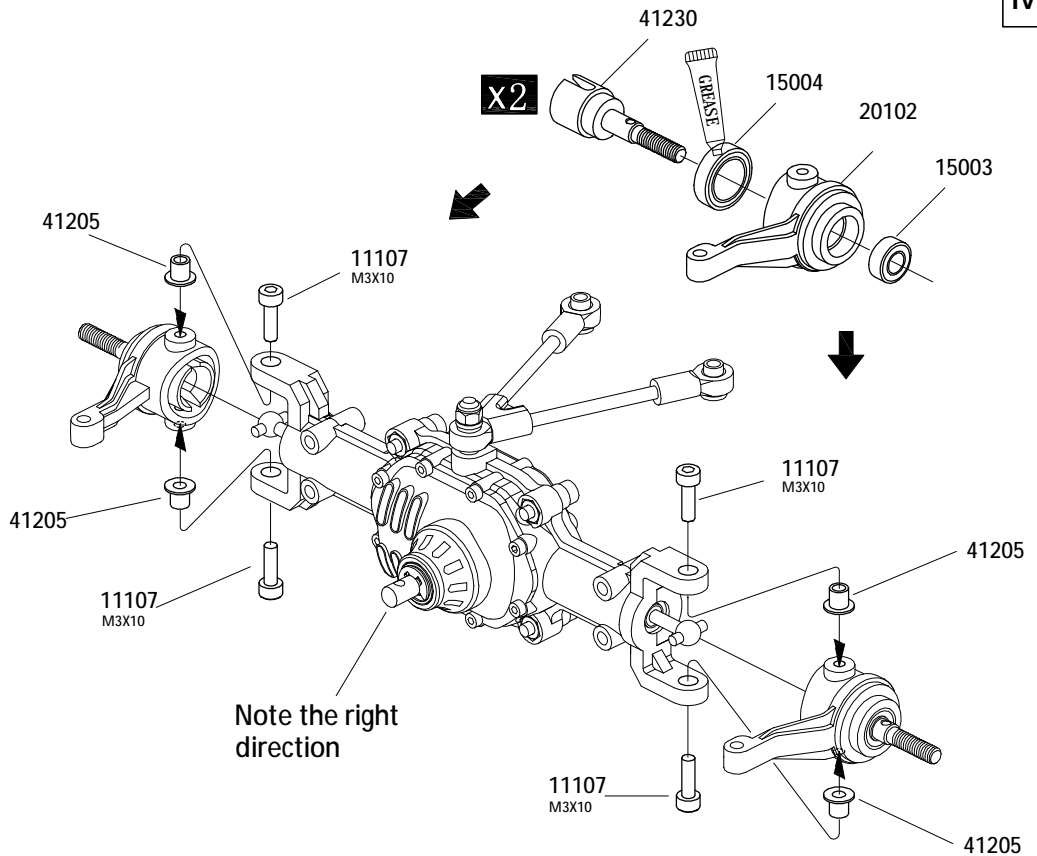

x2

18

MC8B

11102 
M2x6 X8

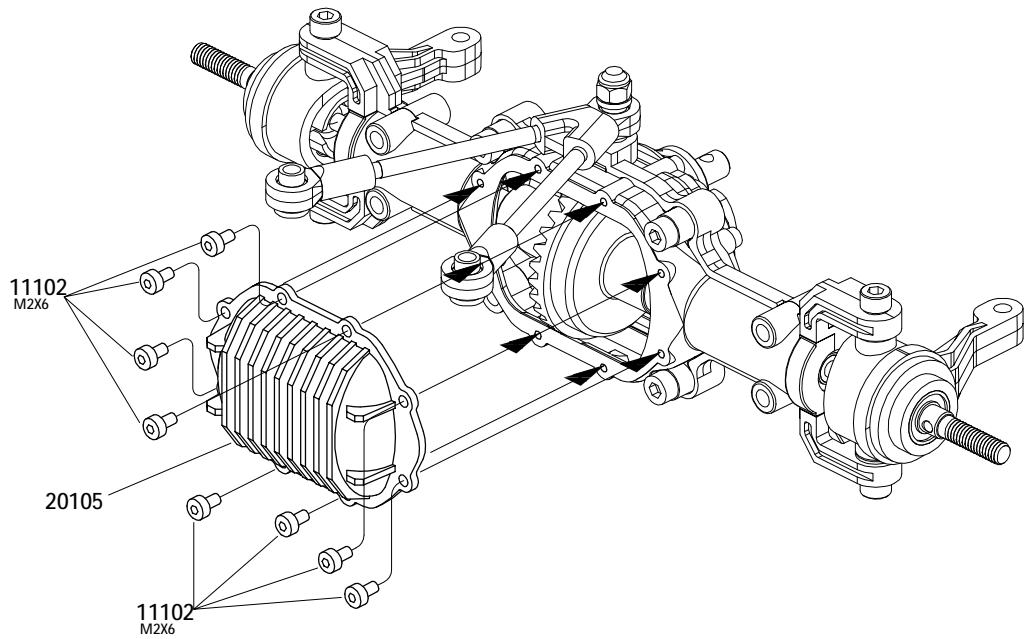

19

MC8B

11102 
M2x6 X8

15003 
φ5xφ10x4 X2

13002 
φ4xφ9x0.6 X1

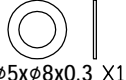
72007 
φ5xφ8x0.3 X1

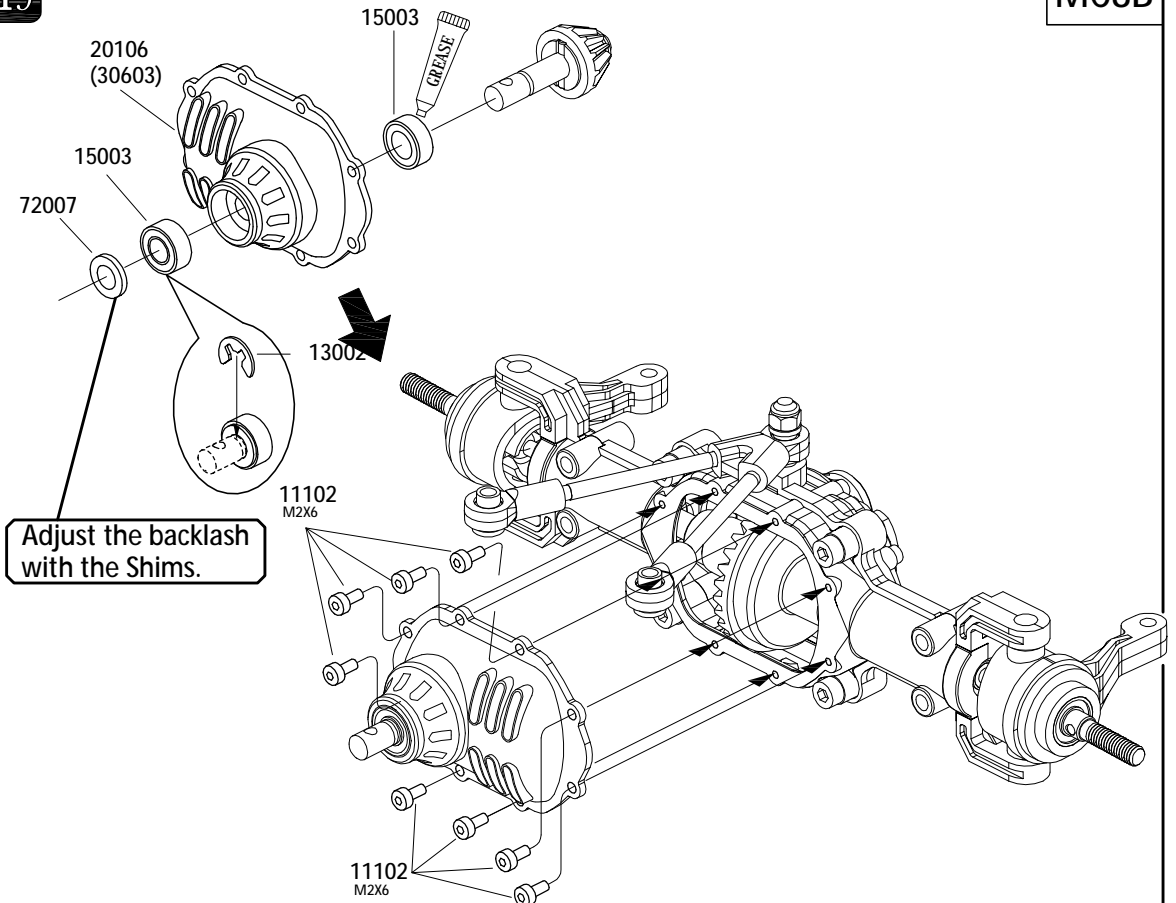

20

MC8B





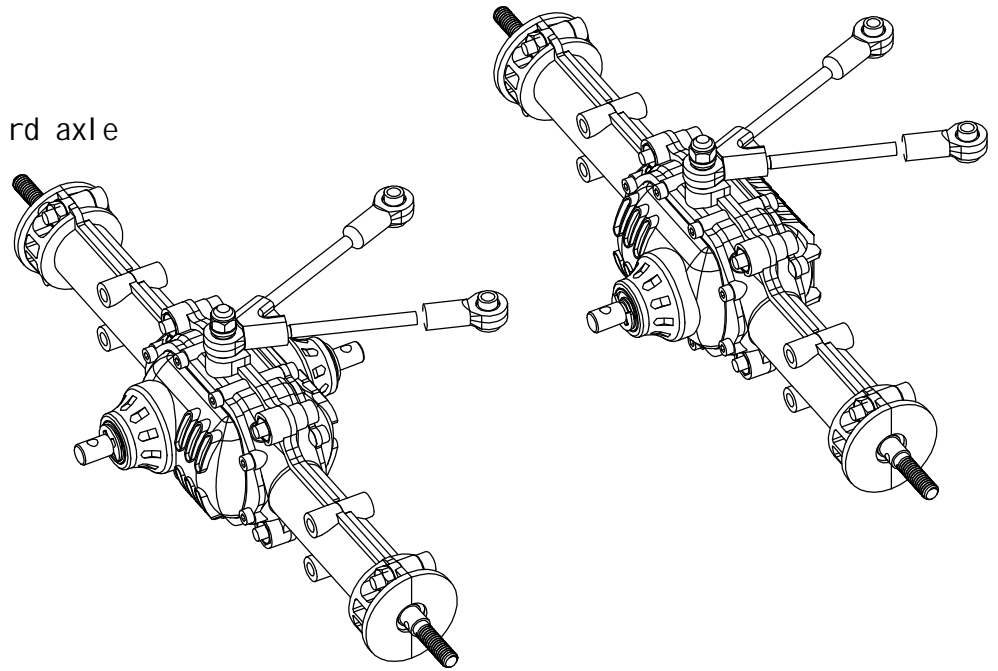



The third axle

The fourth axle



21

MC8B



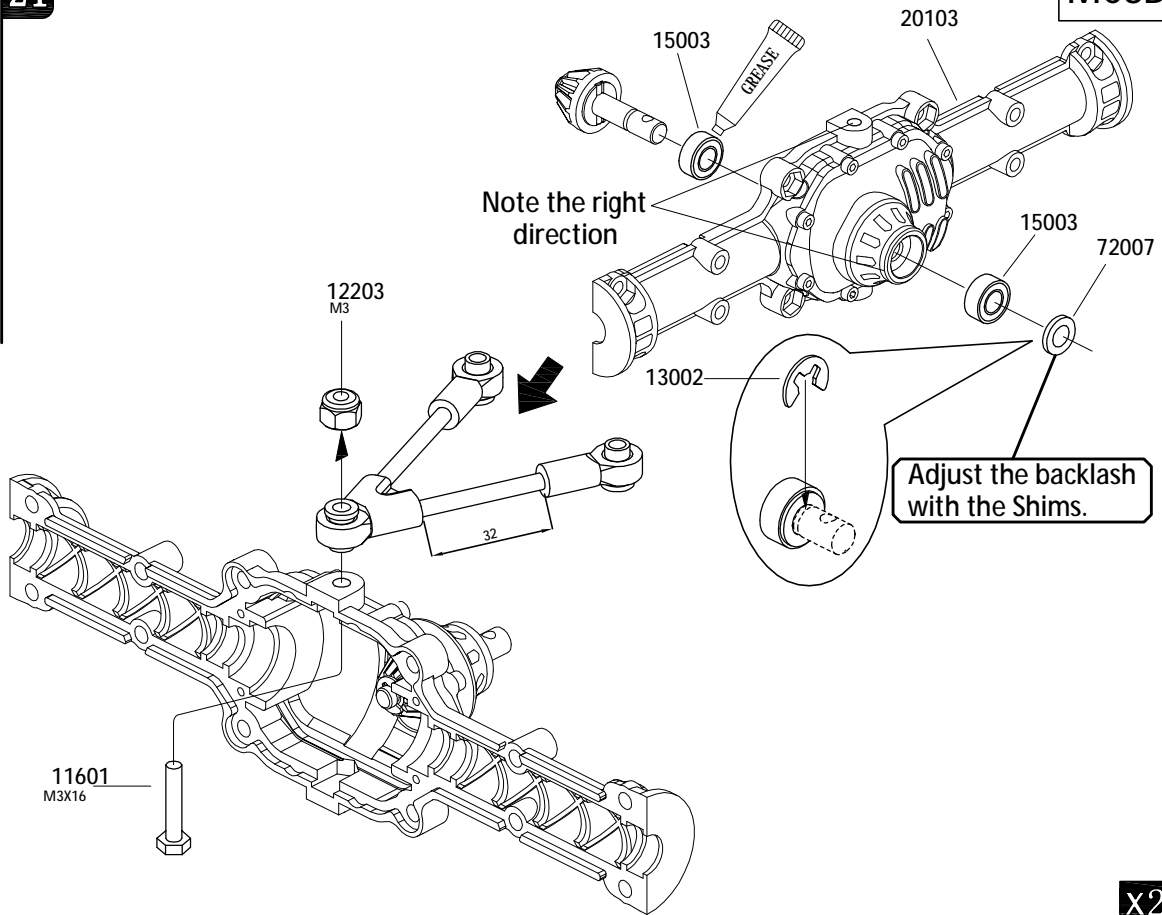



- 12203  
M3 X1
- 11601 
M3x16 X1
- 15003  
φ5xφ10x4 X2
- 13002  
φ4xφ9x0.6 X1
- 72007  
φ5xφ8x0.3 X1



X2

22



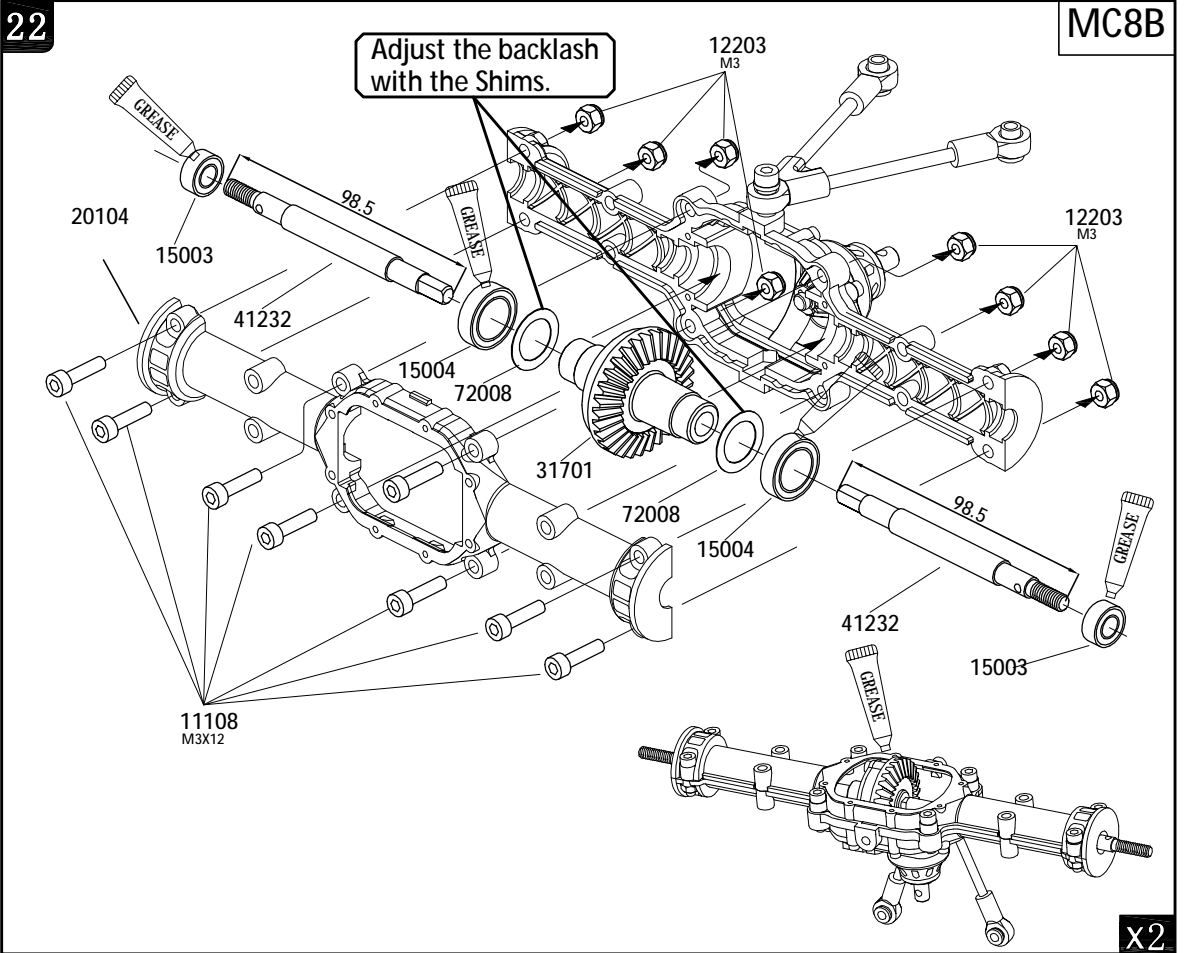

MC8B

- 12203  M3 X16
 - 11108  M3x12 X16
 - 15003  $\phi 5 \times \phi 10 \times 4$ X4
 - 15004  $\phi 10 \times \phi 15 \times 4$ X4
 - 72008  $\phi 10.2 \times \phi 15 \times 0.2$ X4
- 

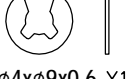
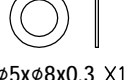

23

MC8B

- 11102  M2x6 X8
 - 15003  $\phi 5 \times \phi 10 \times 4$ X2
 - 13002  $\phi 4 \times \phi 9 \times 0.6$ X1
 - 72007  $\phi 5 \times \phi 8 \times 0.3$ X1
- 

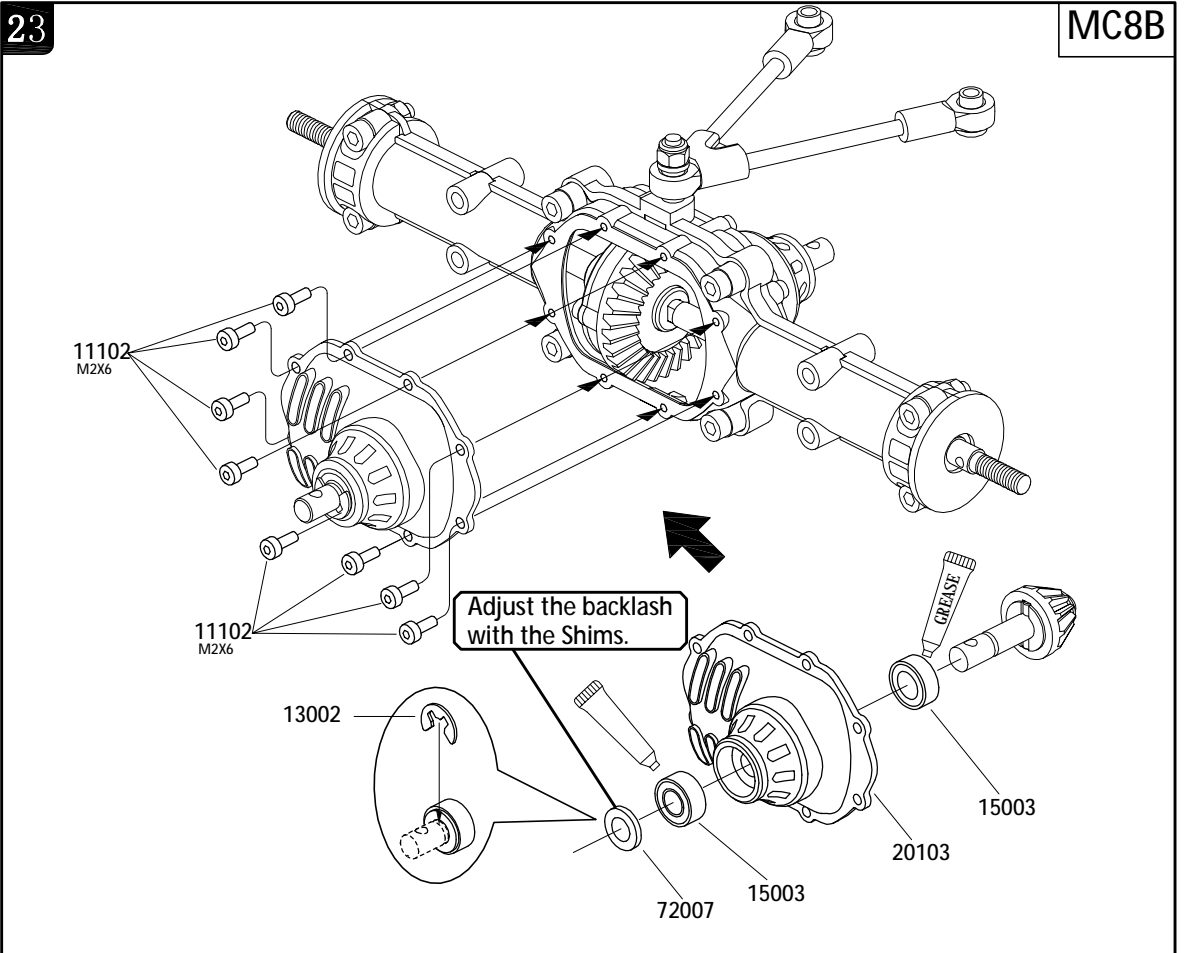

24

MC8B

11102 
M2x6 X8

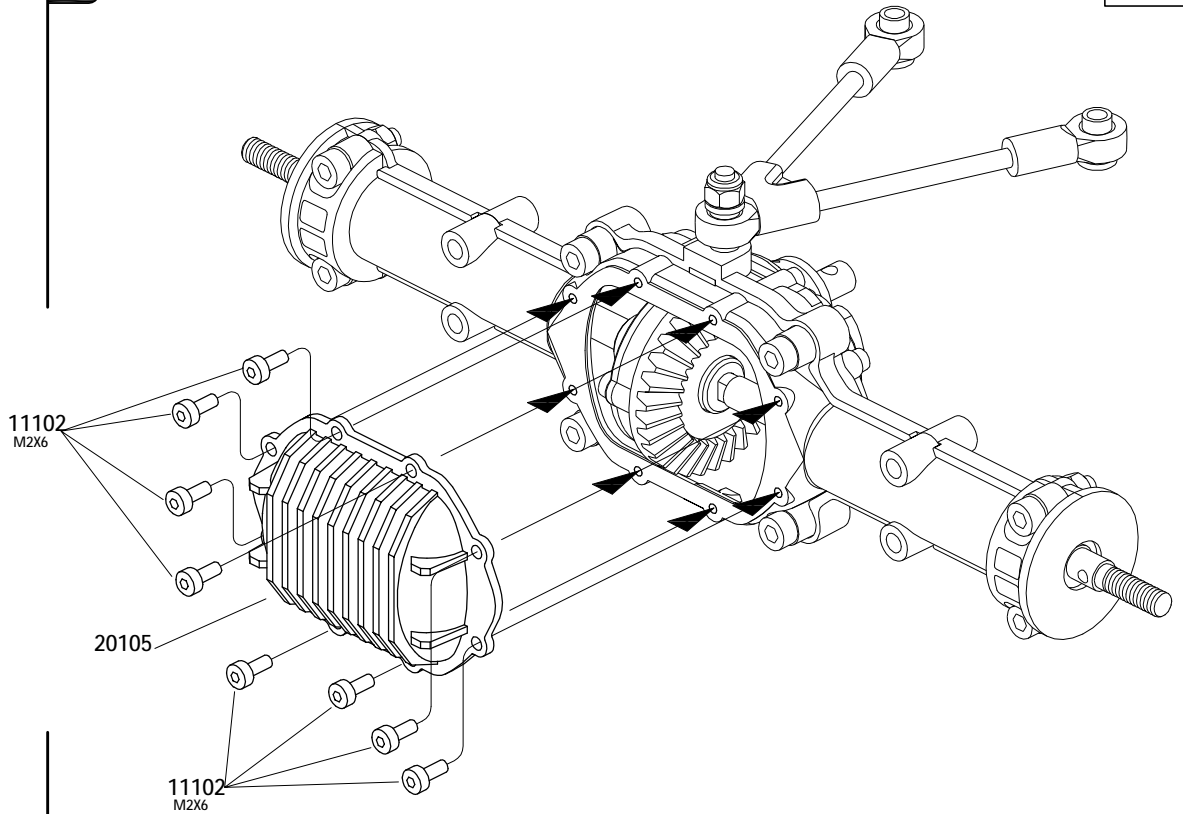

25

MC8C

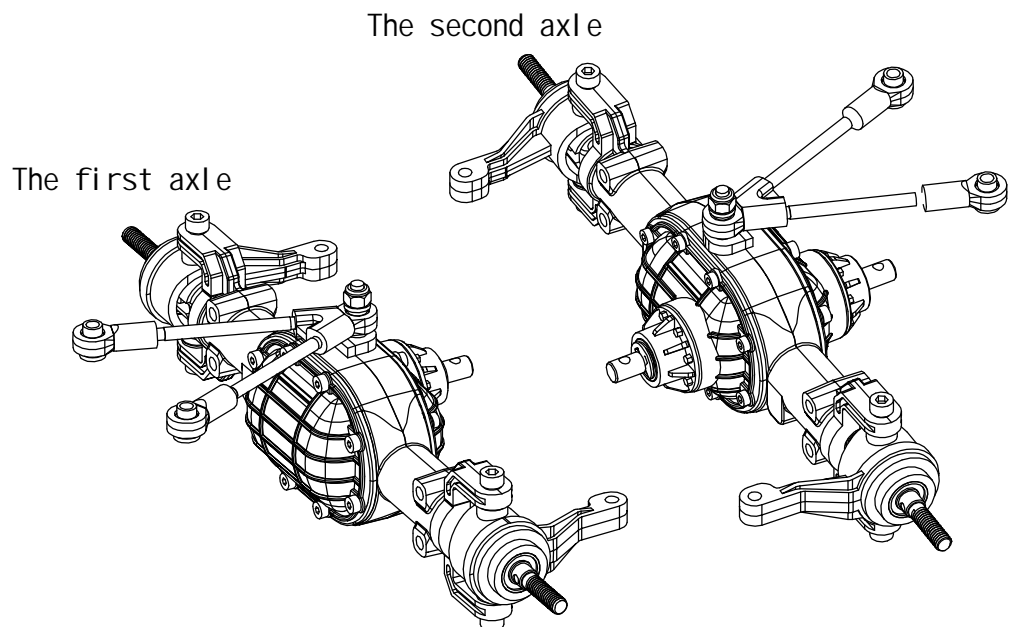



12203
M3 X2

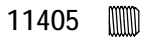

11405
M4x4 X2



15003
φ5xφ10x4 X4

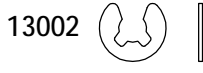

13002
φ3.8xφ9.2x0.6 X2

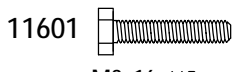

11601
M3x16 X2



72007
φ5xφ8x0.3 X2



26

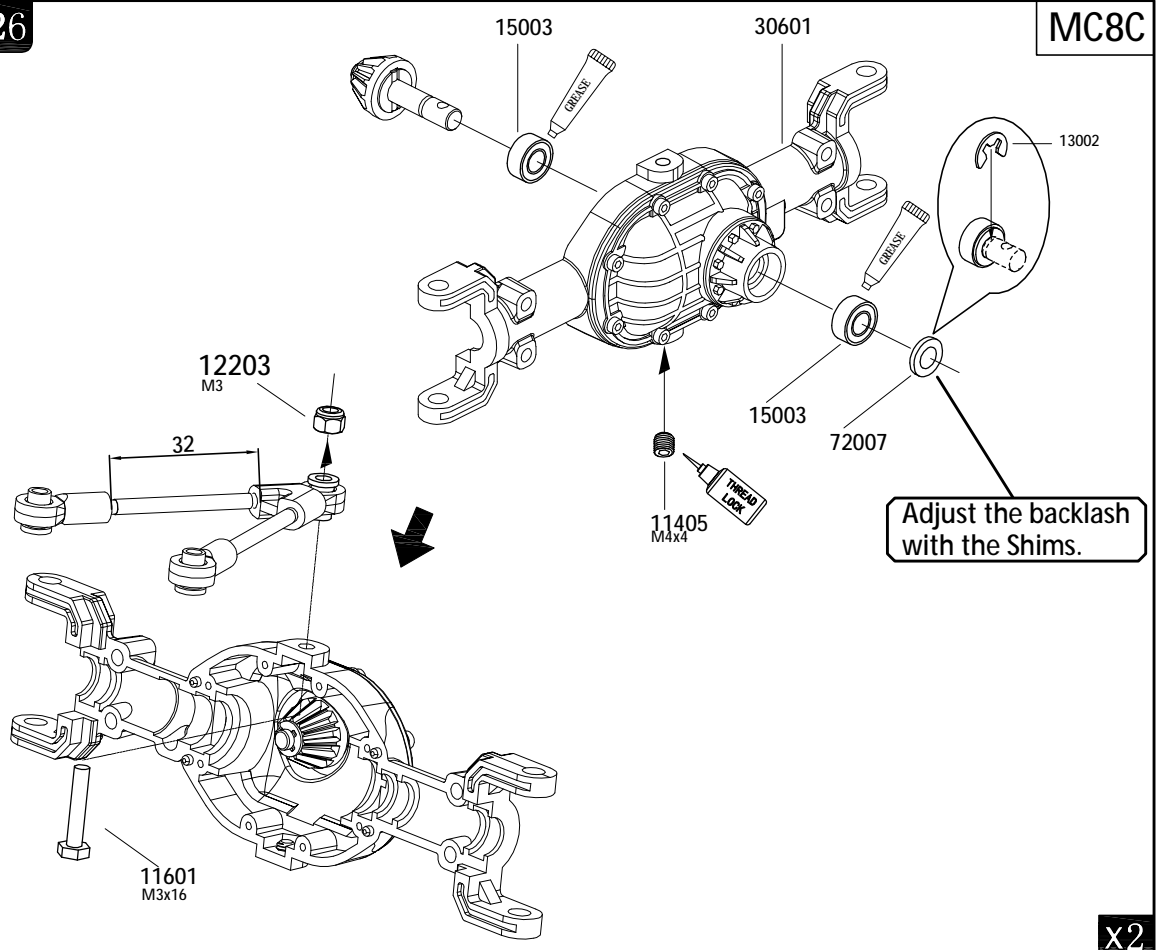

MC8C

X2



15003
φ5xφ10x4 X4



15004
φ10xφ15x4 X4



13002
φ3.8xφ9.2x0.6 X4



72008
φ10.2xφ15x0.2 X4



27

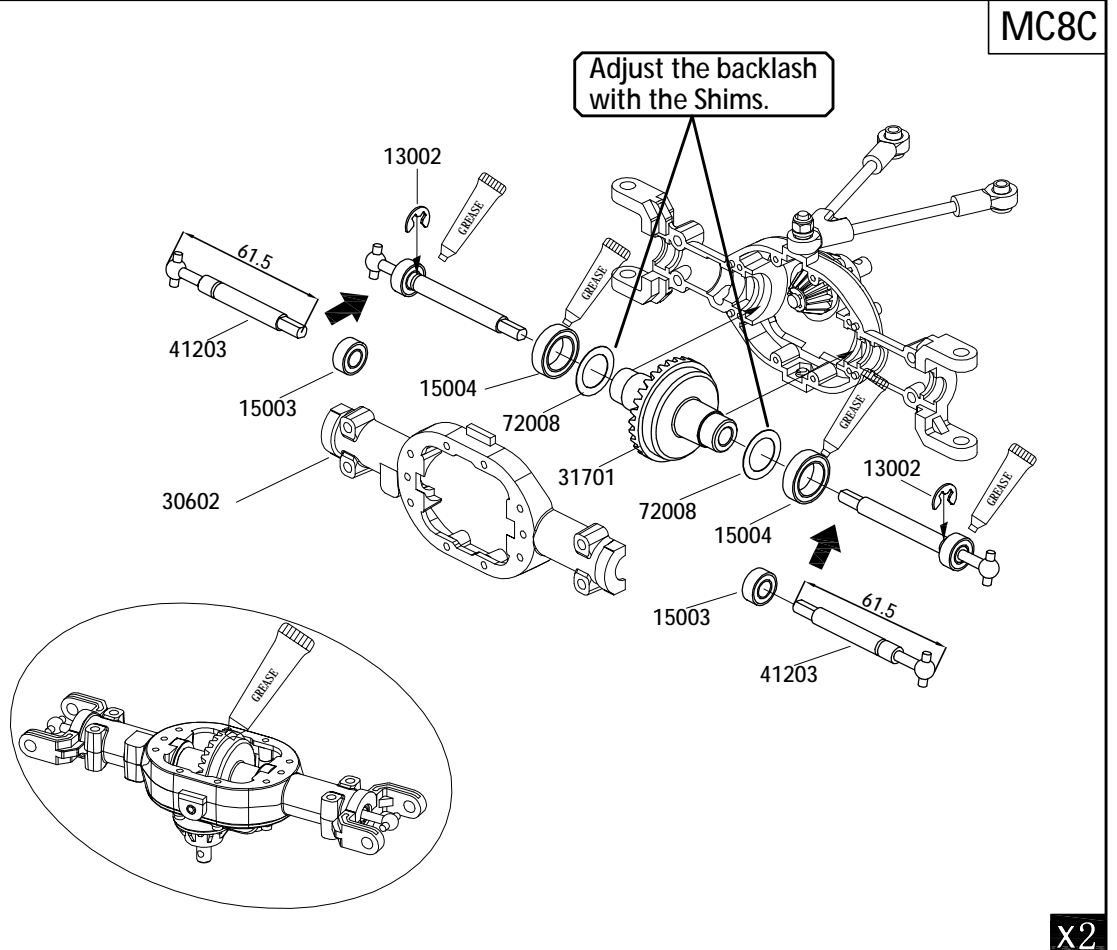

MC8C

X2

28

MC8C

11126 M2x14 X8



30703

11126 M2X14

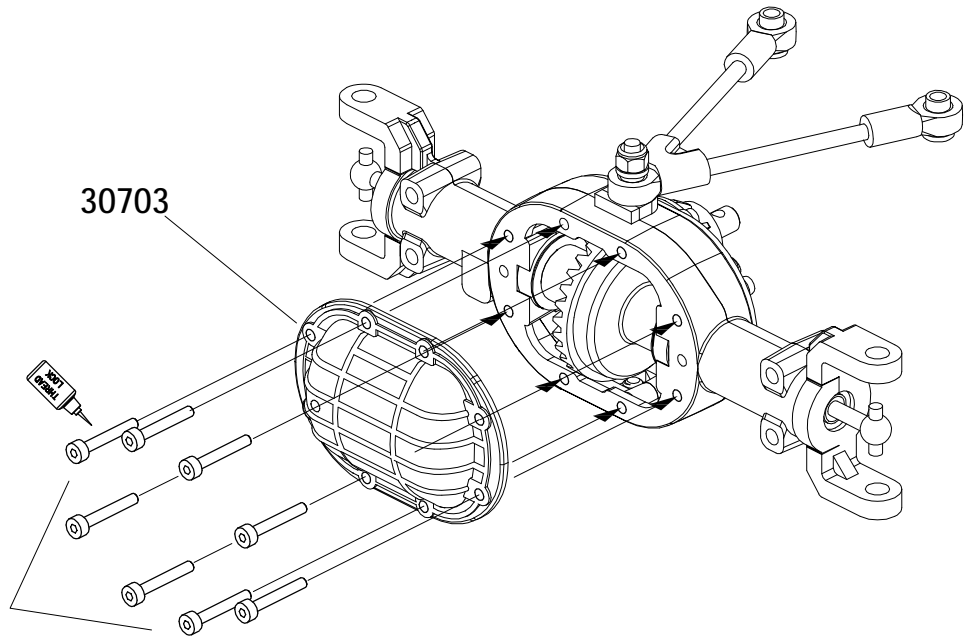

29

MC8C

11126 M2x14 X8

15003 $\phi 5 \times \phi 10 \times 4$ X2

13002 $\phi 3.8 \times \phi 9.2 \times 0.6$ X1

72007 $\phi 5 \times \phi 8 \times 0.3$ X1

11126 M2X14



Adjust the backlash with the Shims.

13002

72003

15003



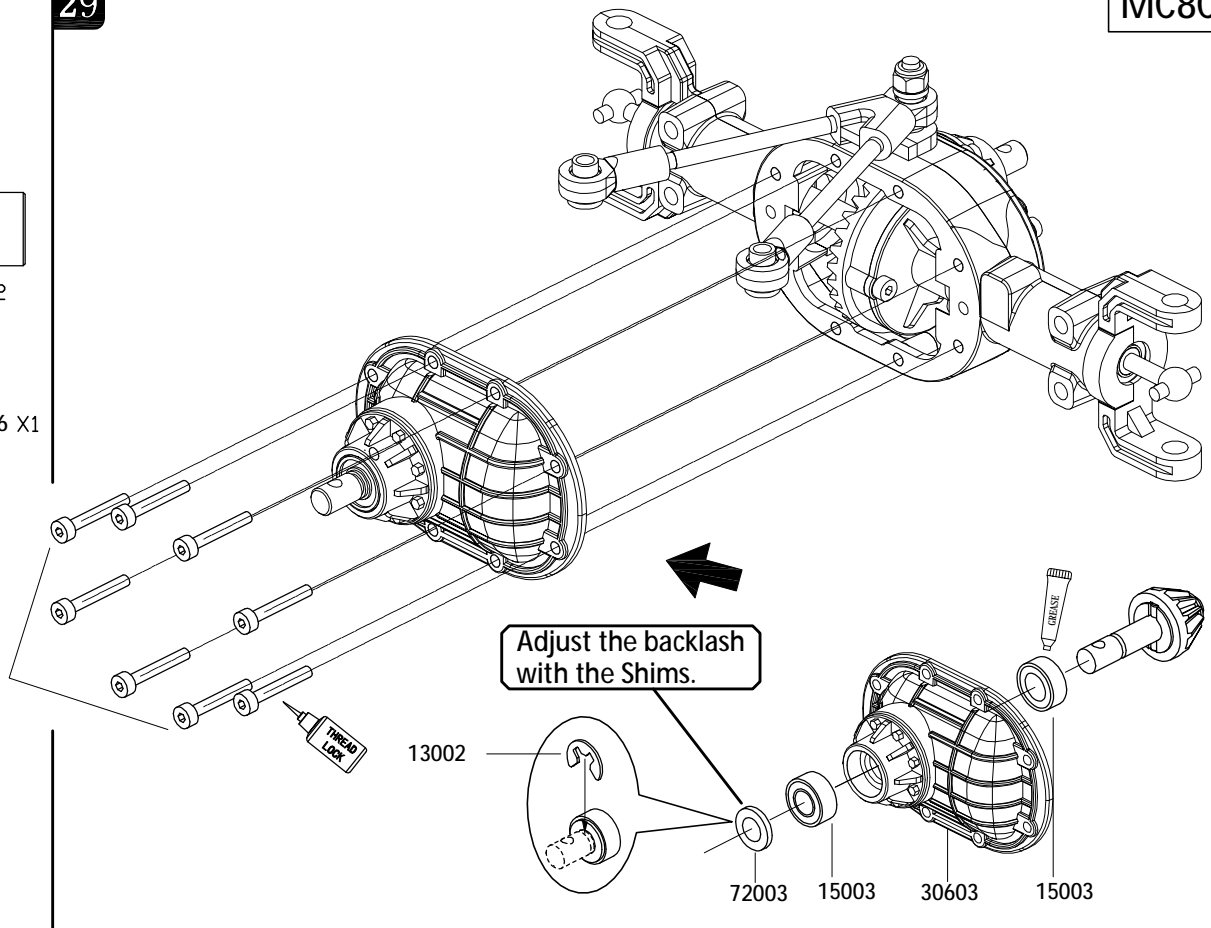

30603

15003



30

MC8C

- 11207  M3x10 X8
- 15003  $\phi 5 \times \phi 10 \times 4$ X4
- 15004  $\phi 10 \times \phi 15 \times 4$ X4
-  **THREAD LOCK**
-  **GREASE**

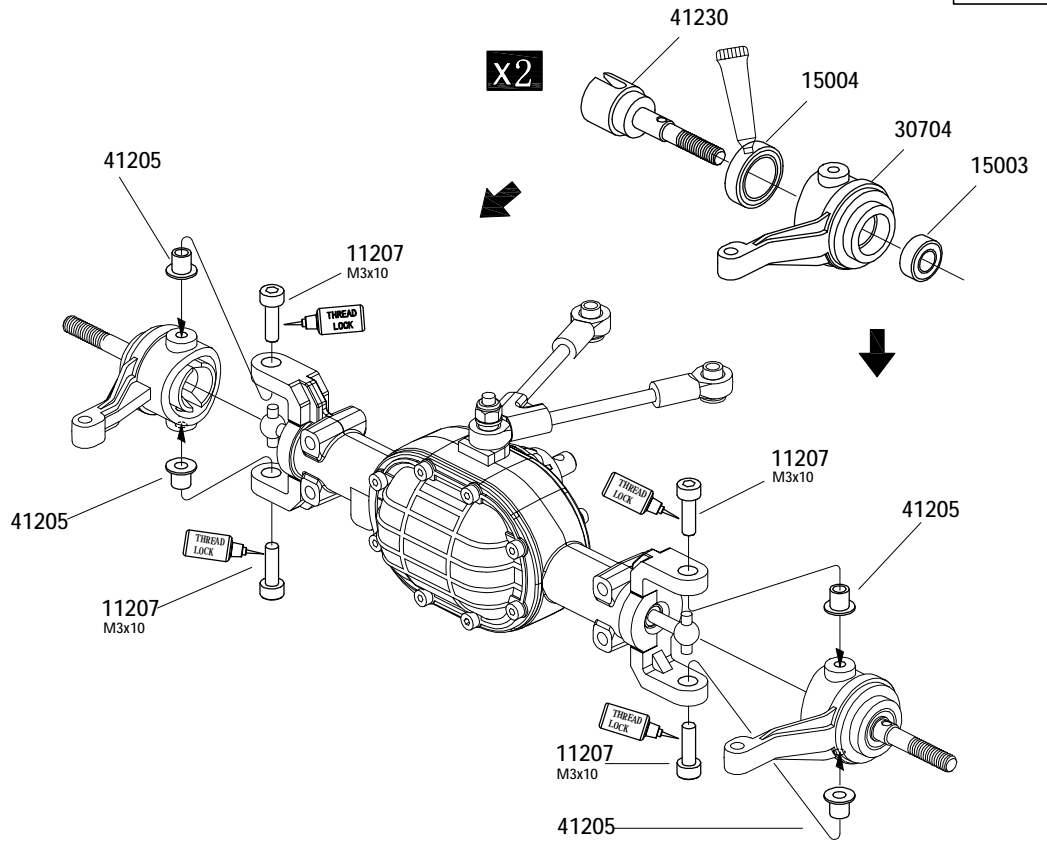

x2

31

MC8C



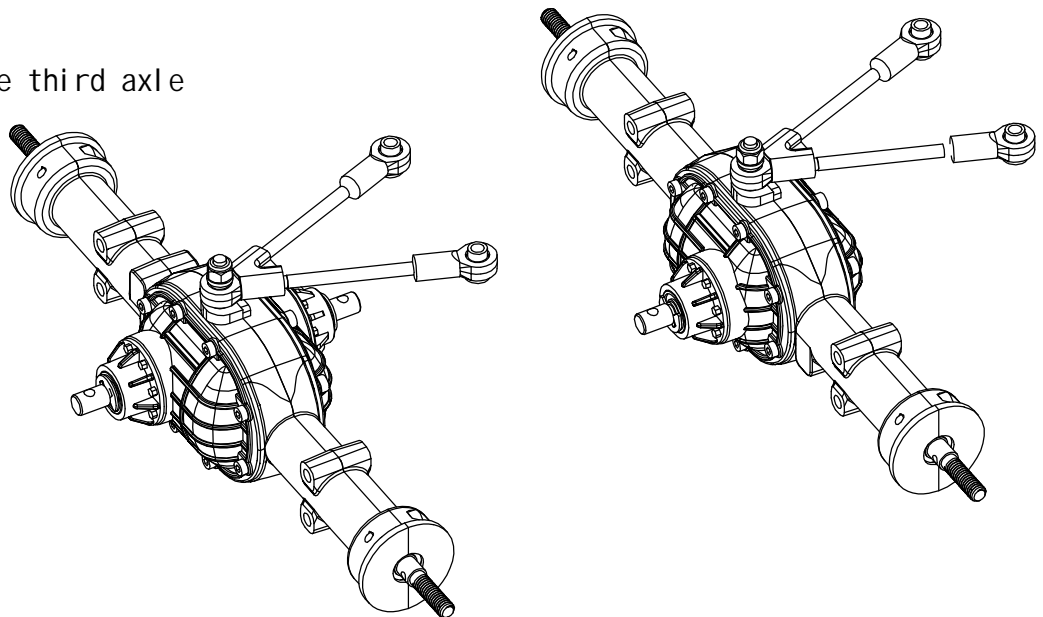

The fourth axle

The third axle

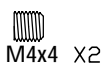
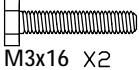

MC8C

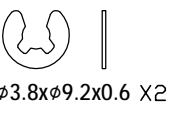
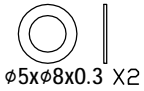
32

- 12203  M3 X2
 - 11405  M4x4 X2
 - 11601  M3x16 X2
 - 15003  $\phi 5 \times \phi 10 \times 4$ X4
 - 13002  $\phi 3.8 \times \phi 9.2 \times 0.6$ X2
 - 72007  $\phi 5 \times \phi 8 \times 0.3$ X2
- 

THREAD
LOCK





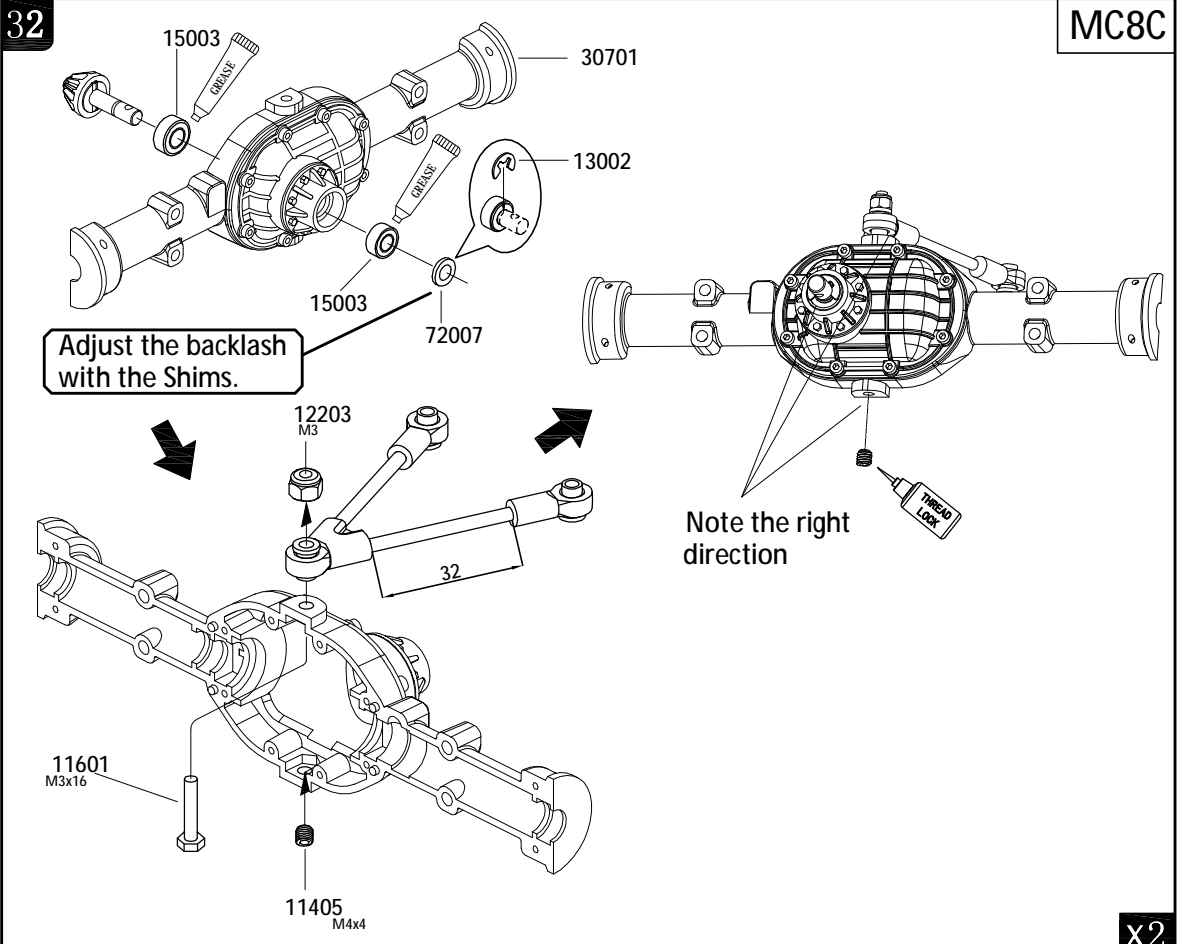

GREASE

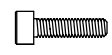

X2

33

MC8C

- 11125  M2.5x10 X8
 - 15003  $\phi 5 \times \phi 10 \times 4$ X4
 - 15004  $\phi 10 \times \phi 15 \times 4$ X4
 - 72008  $\phi 10.2 \times \phi 15 \times 0.2$ X4
- 

THREAD
LOCK



GREASE

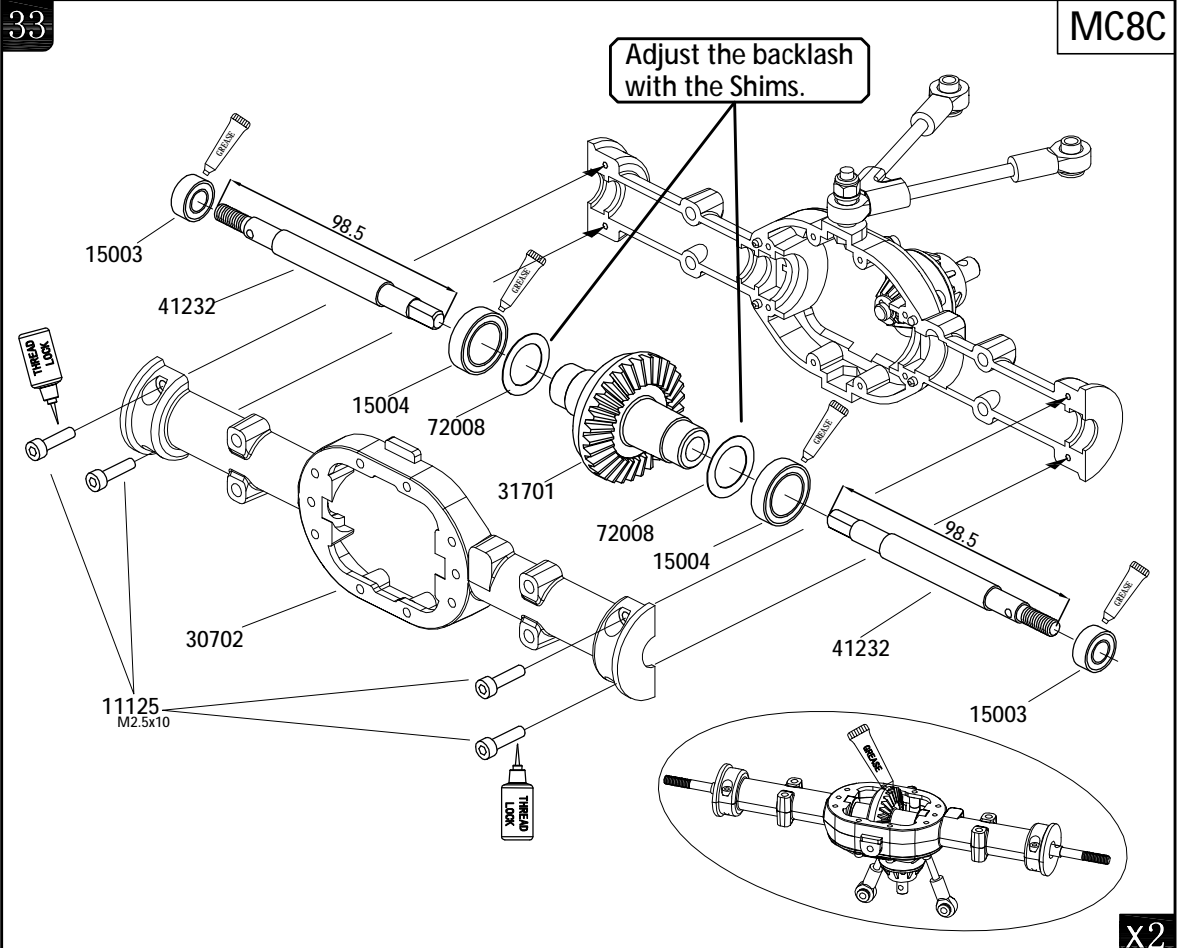





X2



34

MC8C

11126  M2x14 X8

15003   $\phi 5 \times \phi 10 \times 4$ X2

13002   $\phi 3.8 \times \phi 9.2 \times 0.6$ X1

72007   $\phi 5 \times \phi 8 \times 0.3$ X1

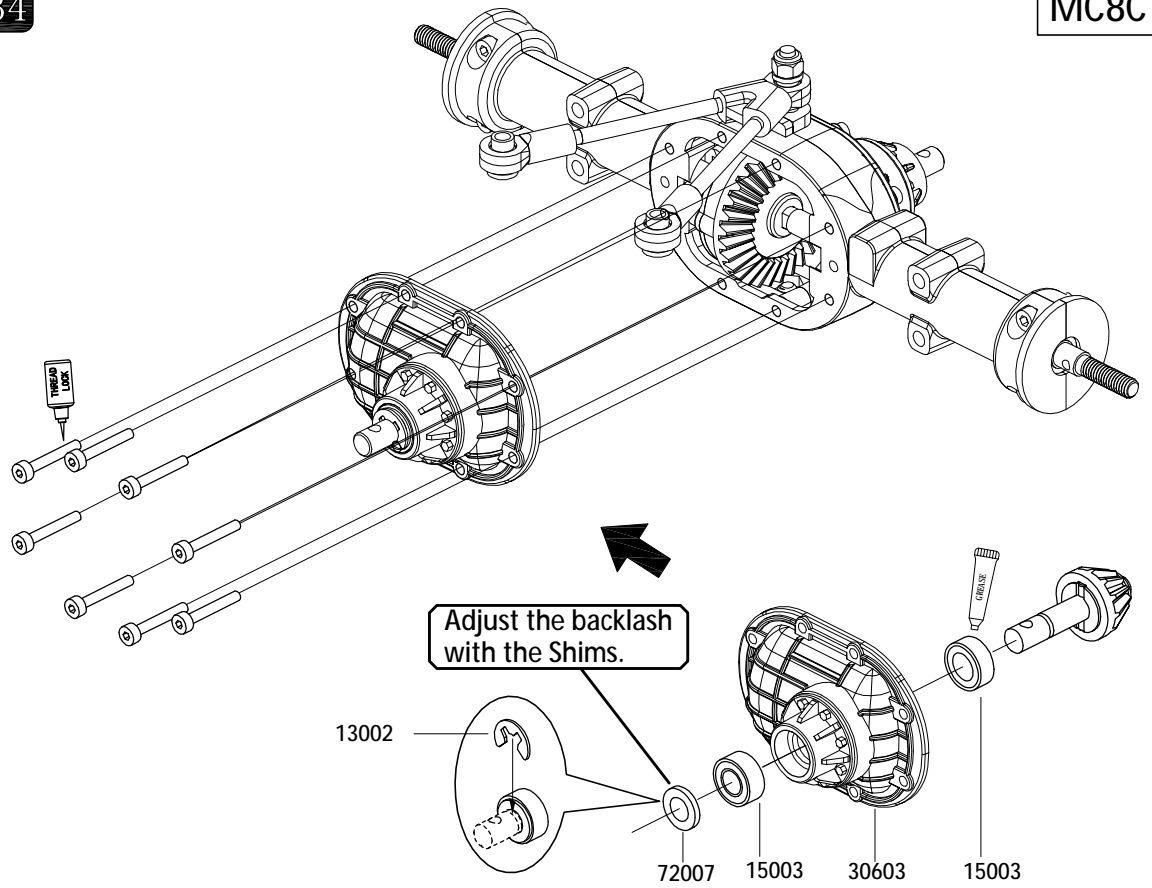
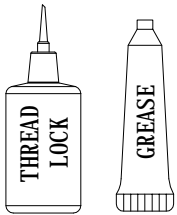

35

MC8C

11126  M2x14 X8

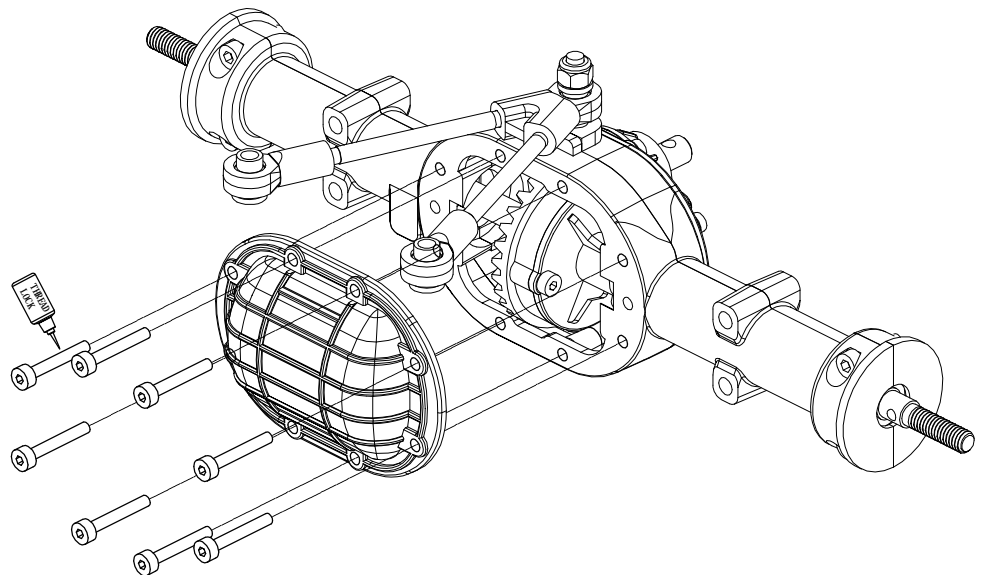

36

MC8B/C

17002  $\phi 6 \times \phi 2.4 \times 1.8$ X16

17001  $\phi 8 \times \phi 6 \times 1.0$ X8

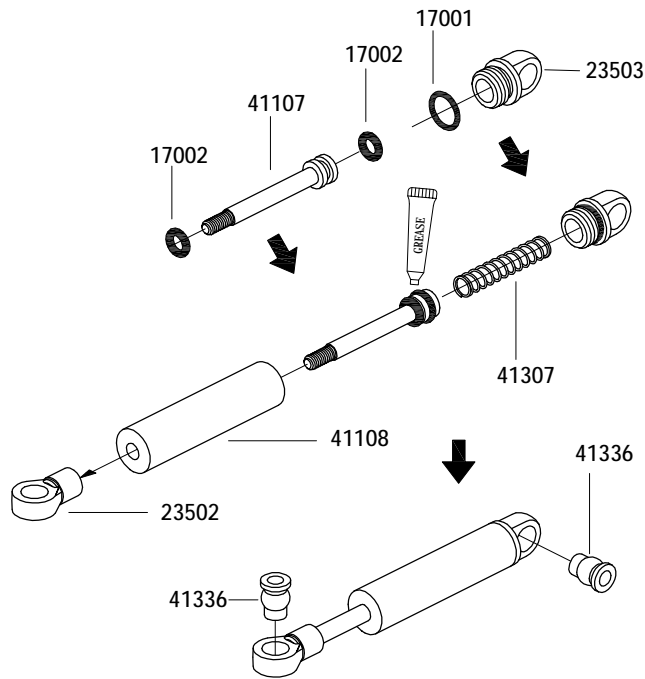

X8

37

MC8B/C

12203  M3 X8

11106  M3x8 X8

14103  $\phi 3.2 \times \phi 9 \times 1$ X8

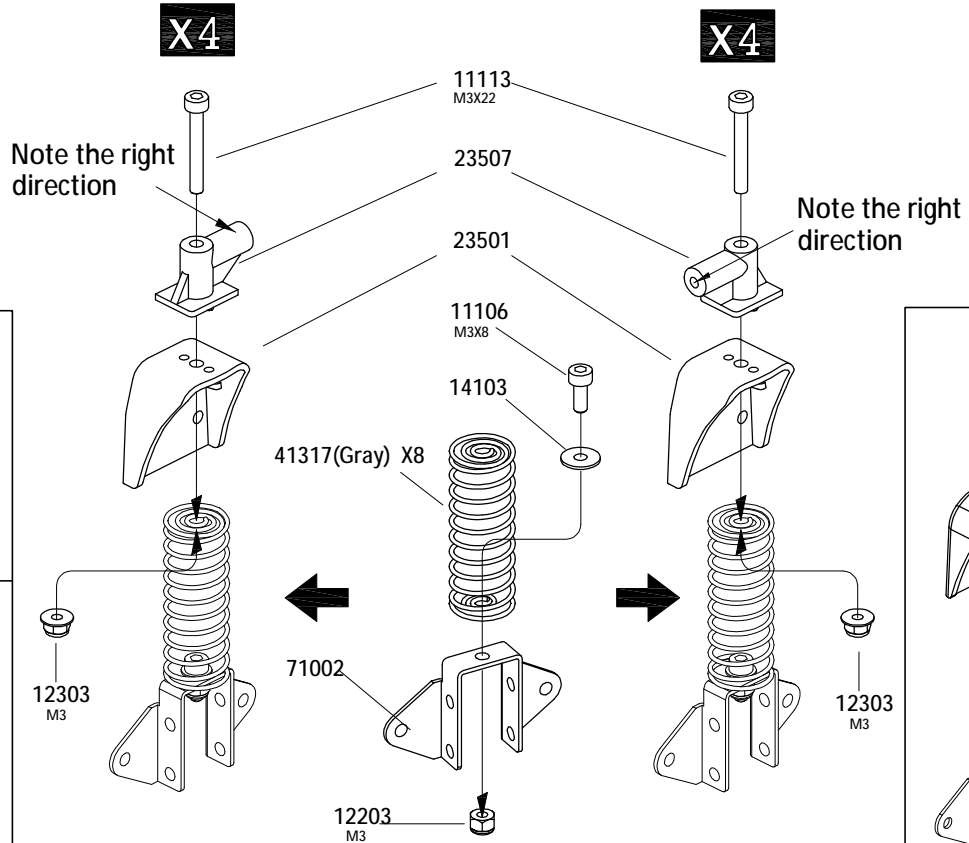

MC8B

11113  M3x22 X8

12303  M3 X8

MC8C

11106  M3x8 X8

14103  $\phi 3.2 \times \phi 9 \times 1$ X8

MC8C

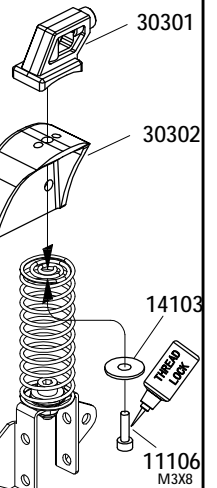

38

MC8B/C

12203  
M3 X16

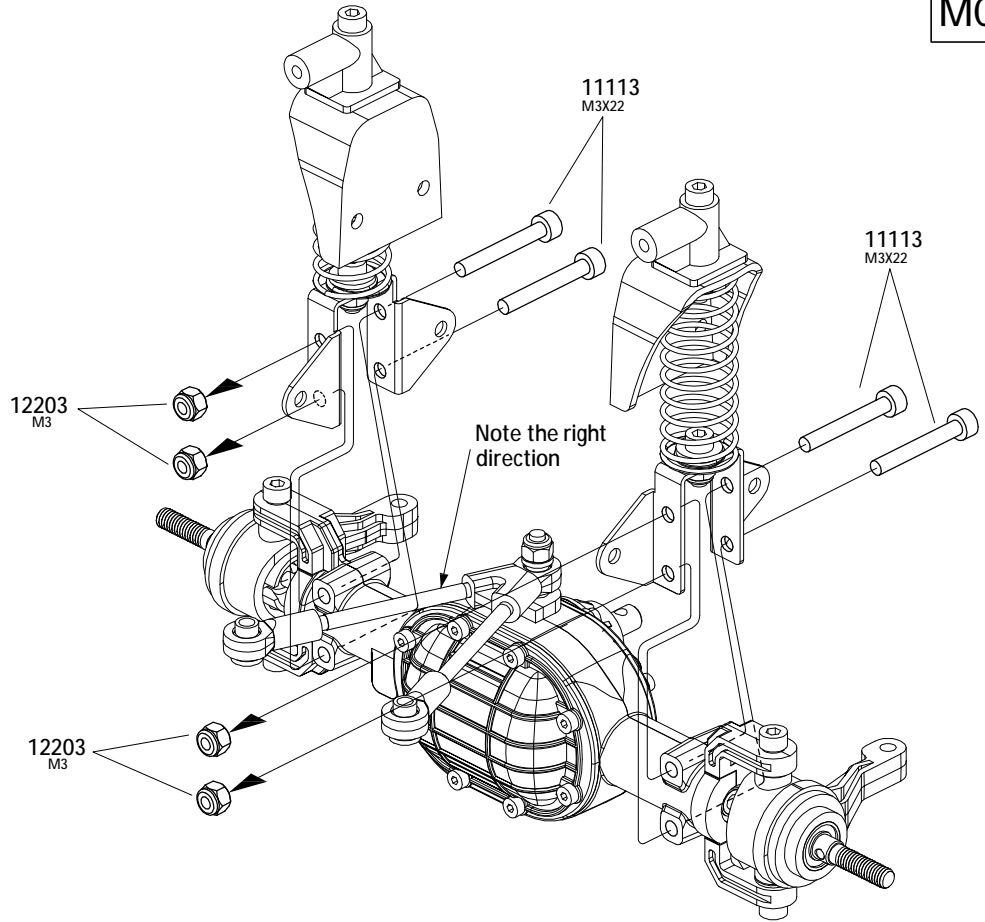

11113 
M3x22 X16



X4

39

MC8B/C

12203  
M3 X8

11109 
M3x14 X16

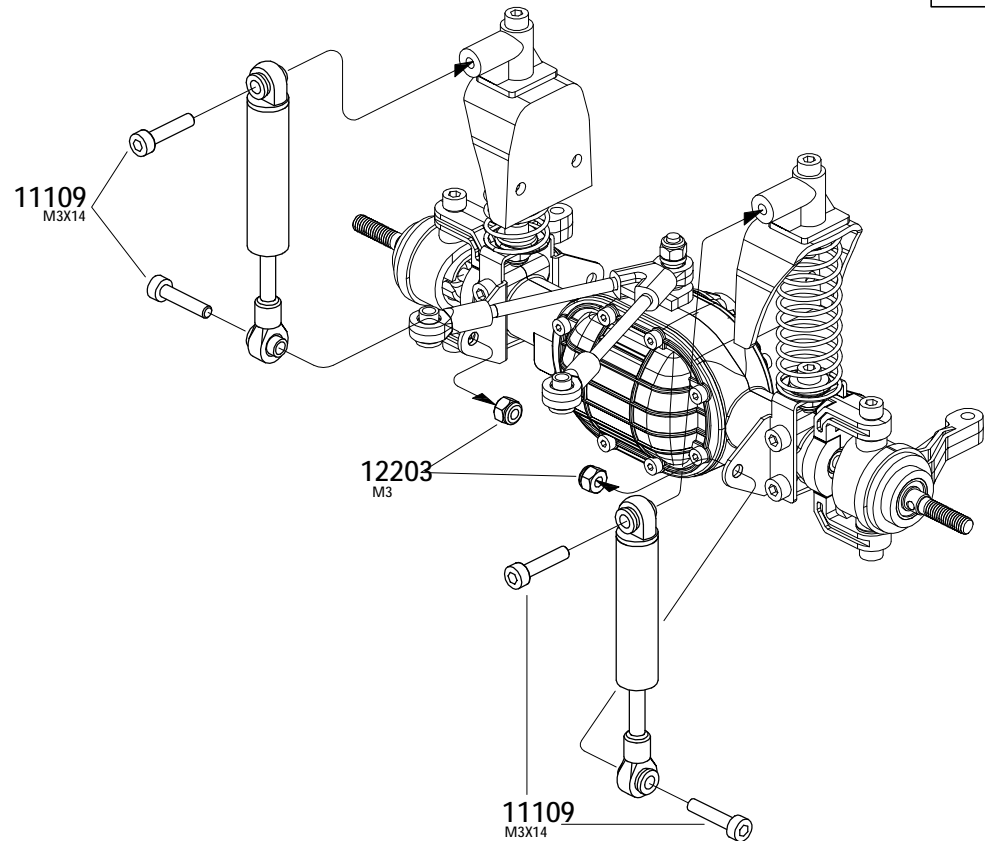

X4

40 The first axle

MC8B/C

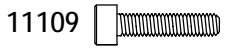

M3x14 X2



M3 X2

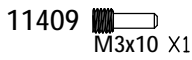
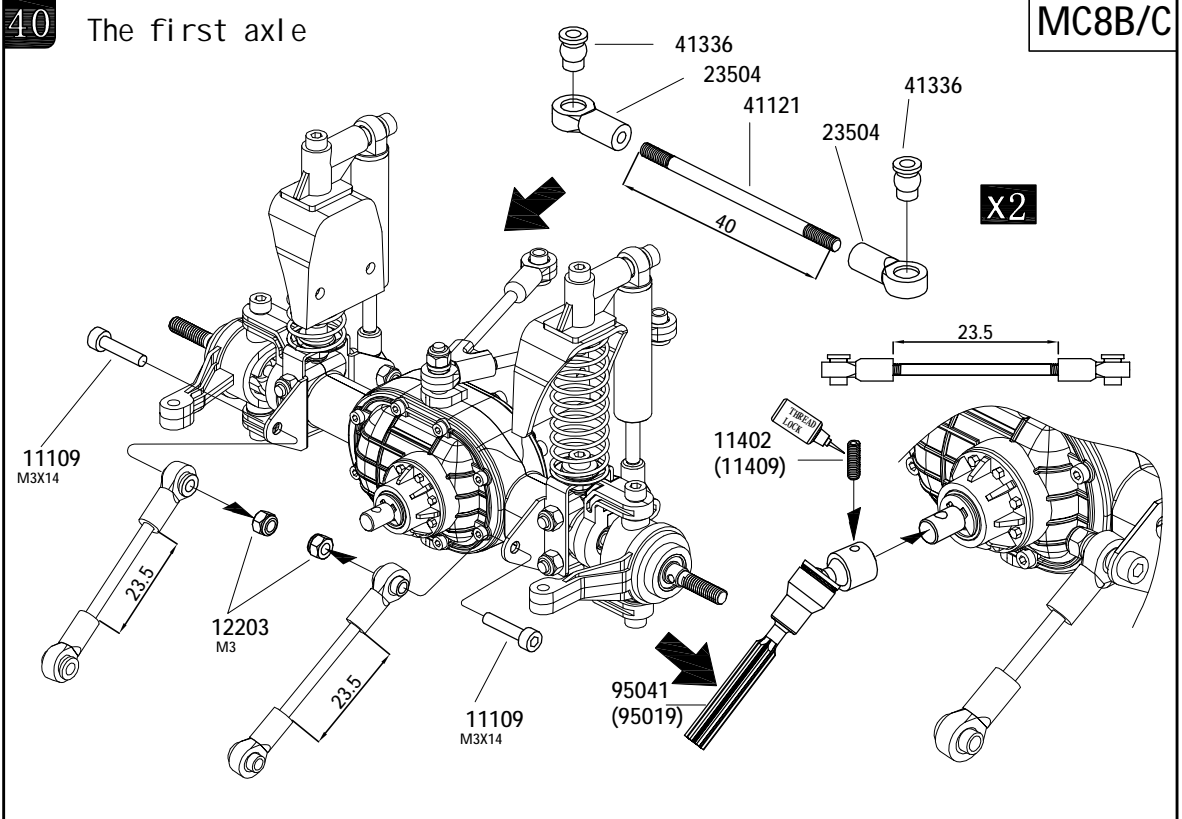

11409 M3x10 X1

MC8B

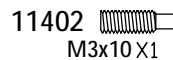

11402 M3x10 X1

MC8C

| | | | |
|-------|----|-------|----|
| 95041 | X1 | 95019 | X1 |
|-------|----|-------|----|

41 The second axle

MC8B/C

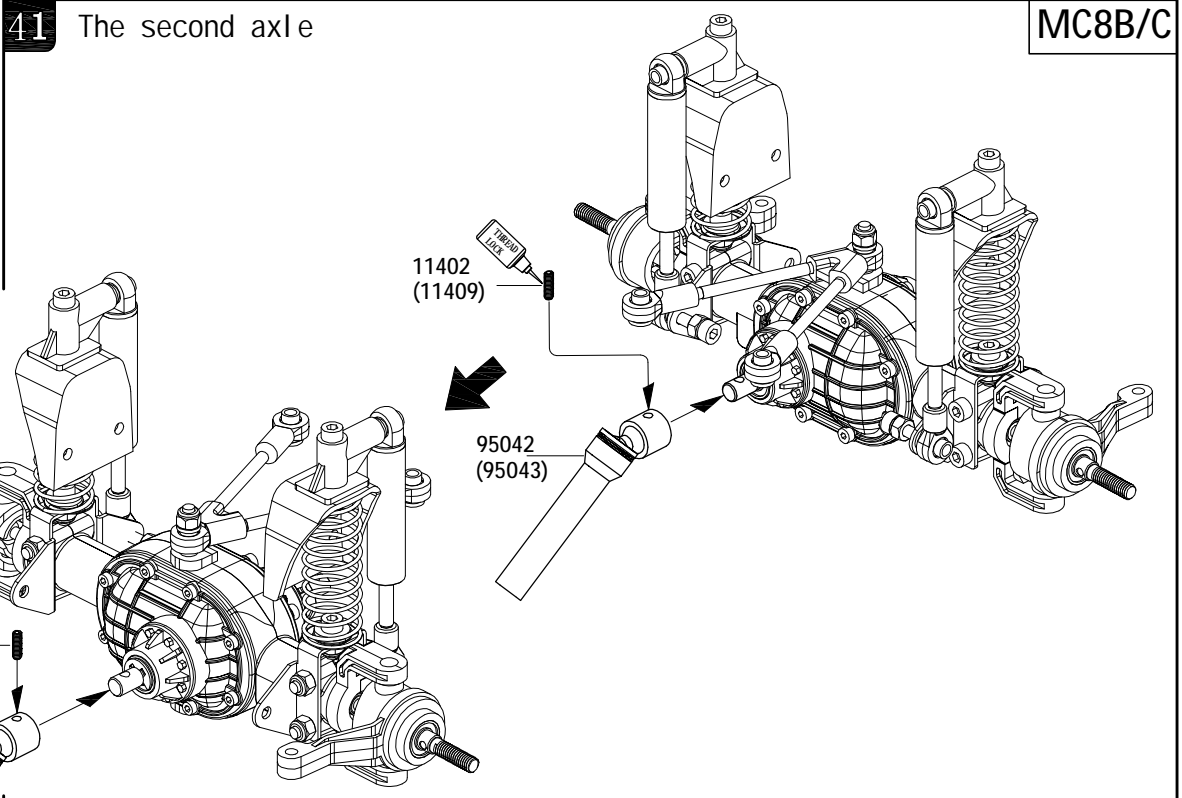

11406 M3x12

95041 (95019)



MC8B

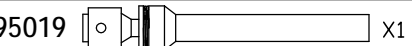

MC8C

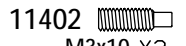

| | | | | | | | |
|-------|----|-------|----|-------|----|-------|----|
| 95041 | X1 | 95019 | X1 | 95043 | X1 | 11402 | X2 |
|-------|----|-------|----|-------|----|-------|----|

42 The second axle

MC8B/C

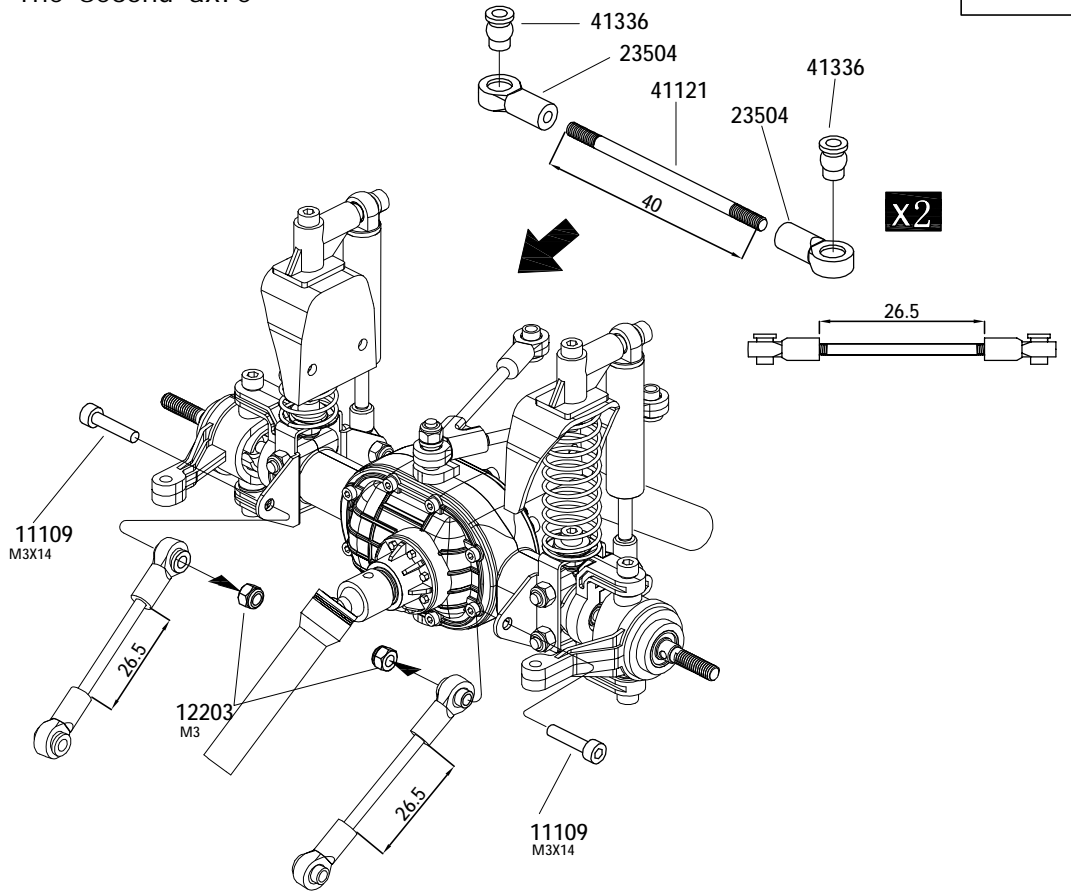
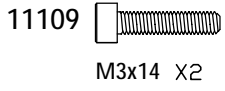
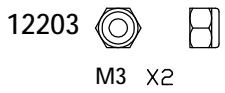

43 The third axle

MC8B/C

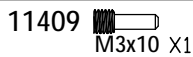
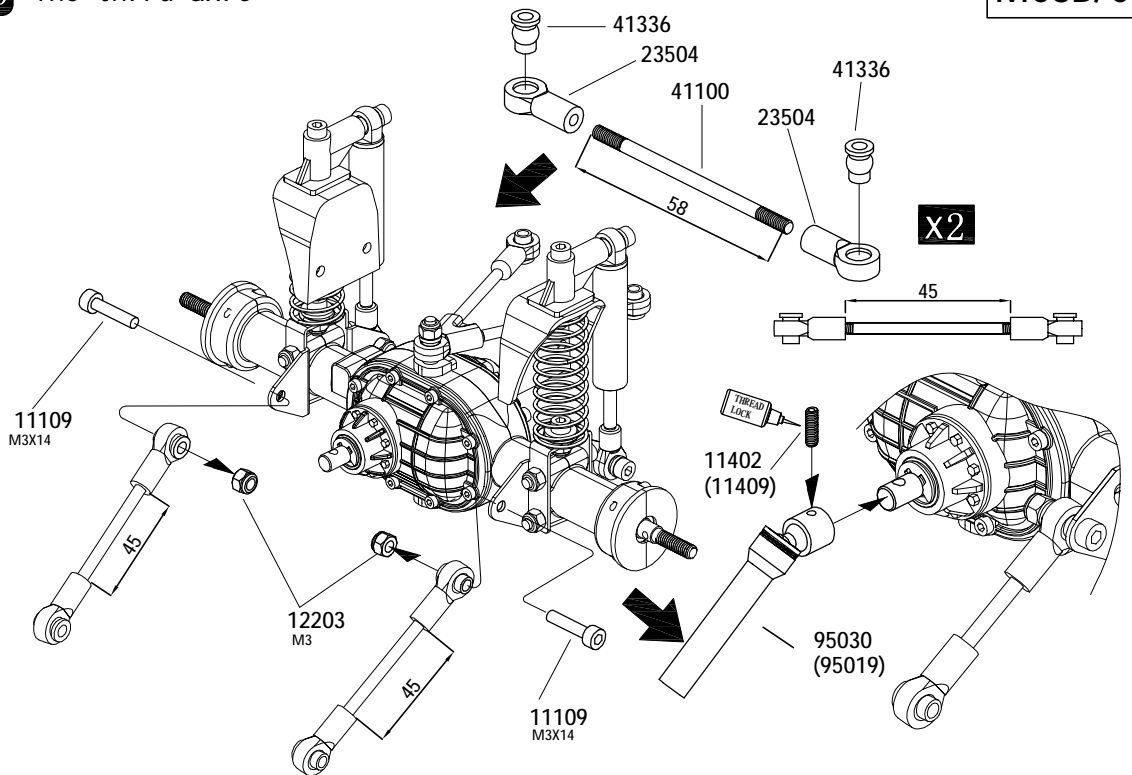
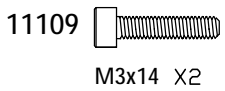

MC8B

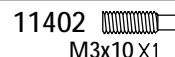

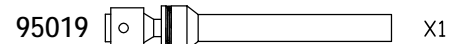
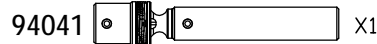

MC8C

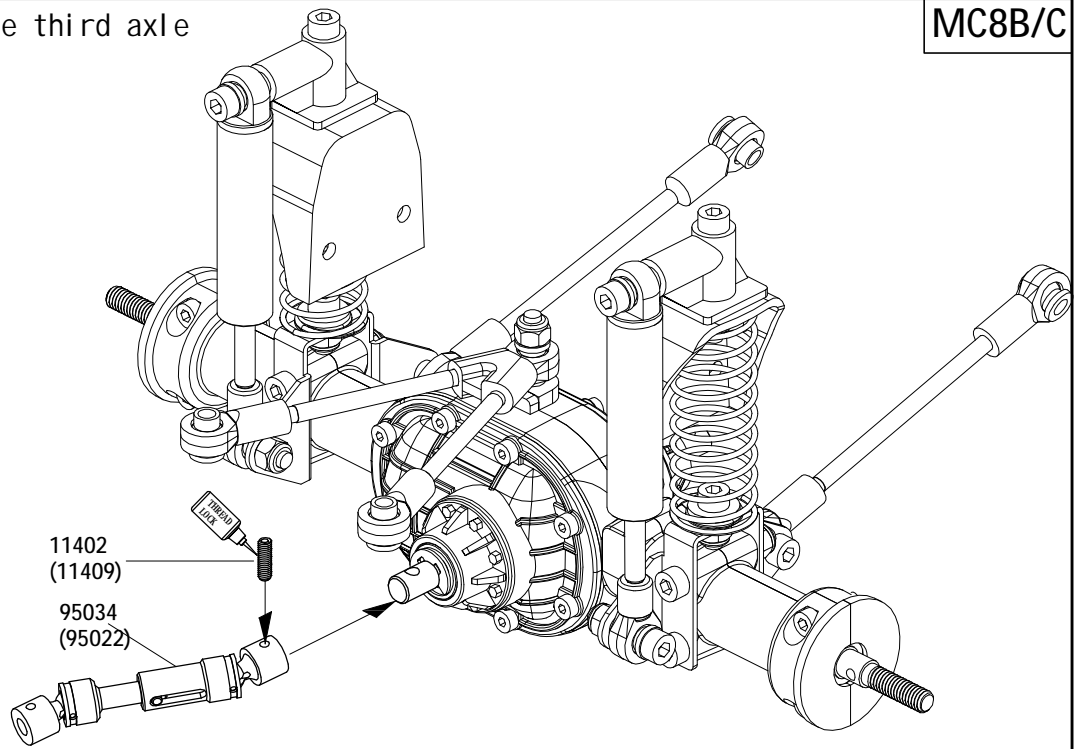

44 The third axle

MC8B/C



11409  M3x10 X1

MC8B

11402  M3x10 X1

MC8C

95034  X1

95022  X1

45 The fourth axle

MC8B/C



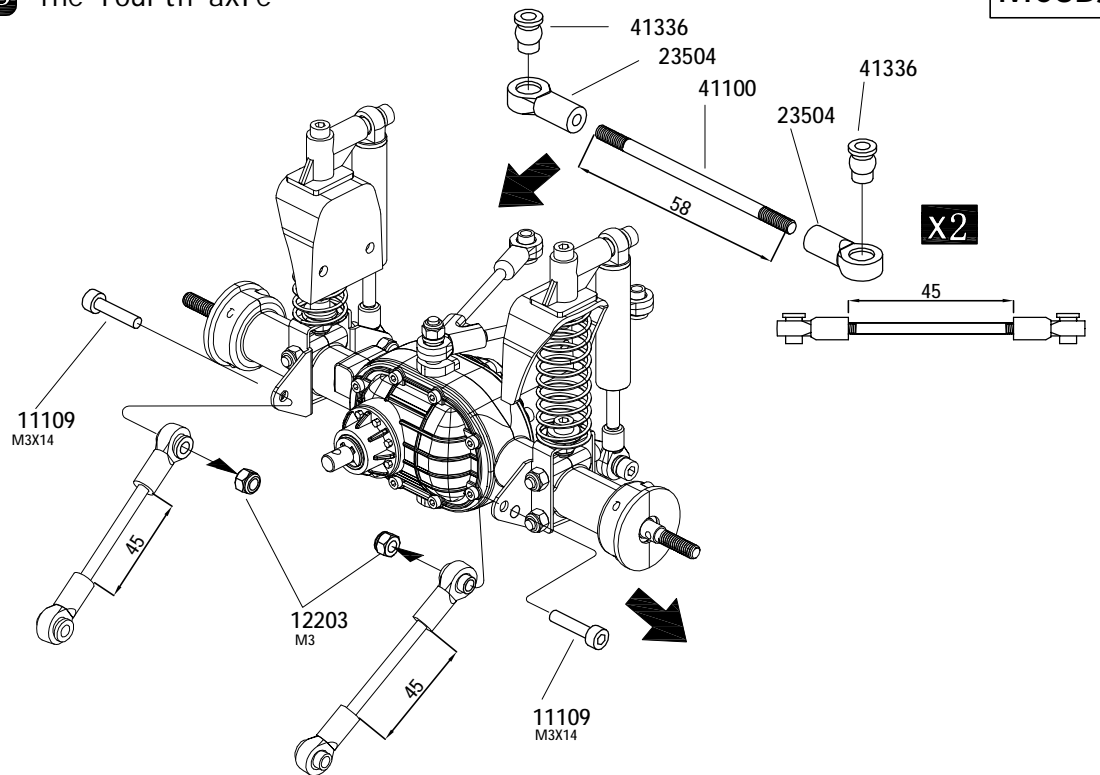

11109  M3x14 X2

12203  M3 X2





46

MC8B/C

- 12203  M3 X8
- 11205  M3x6 X8
- 11109  M3x14 X4
- 11111  M3x18 X4



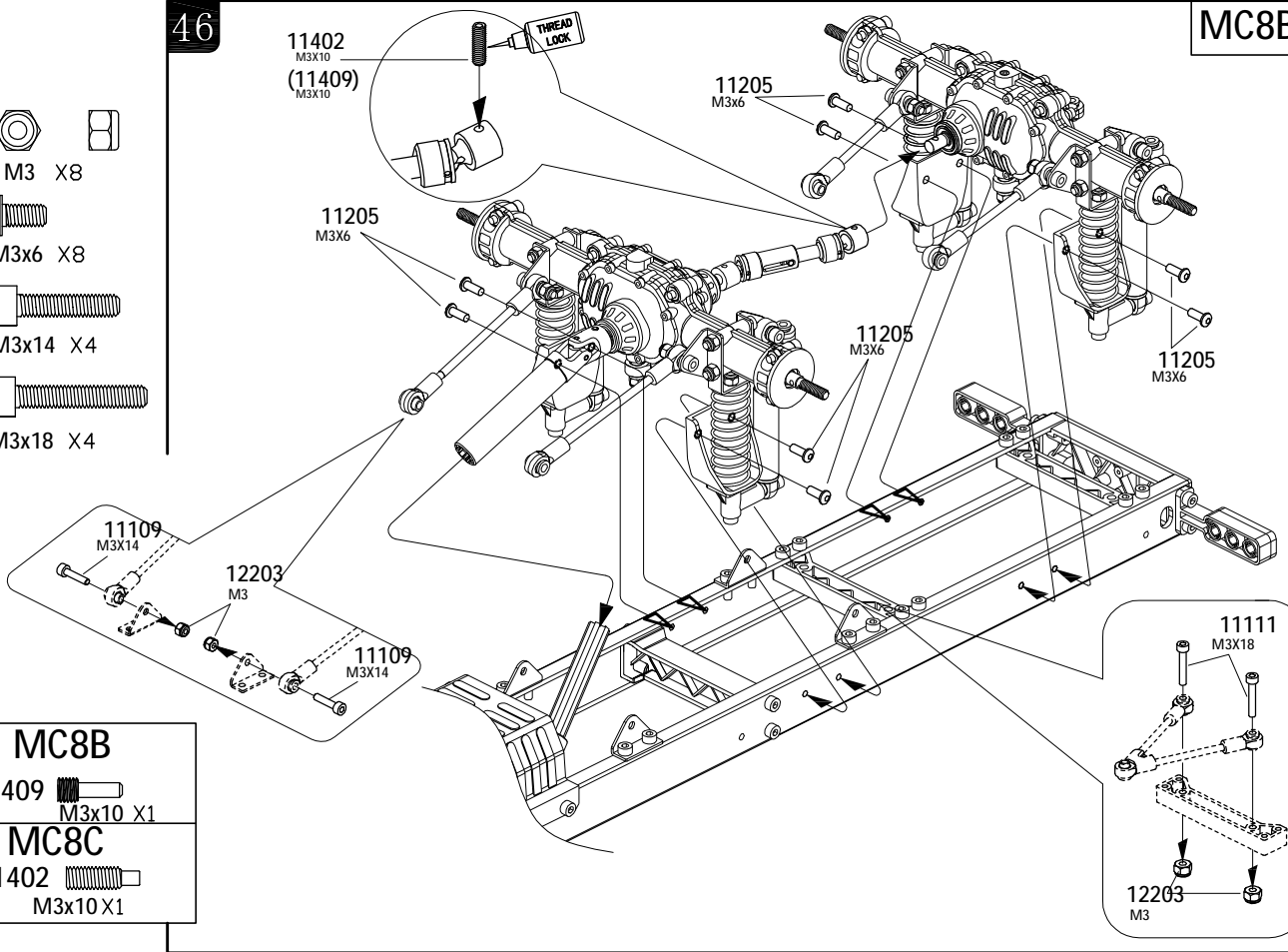

| | | | |
|-------------|---|-------|----------|
| MC8B |  | 11409 | M3x10 X1 |
| MC8C |  | 11402 | M3x10 X1 |







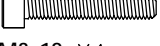

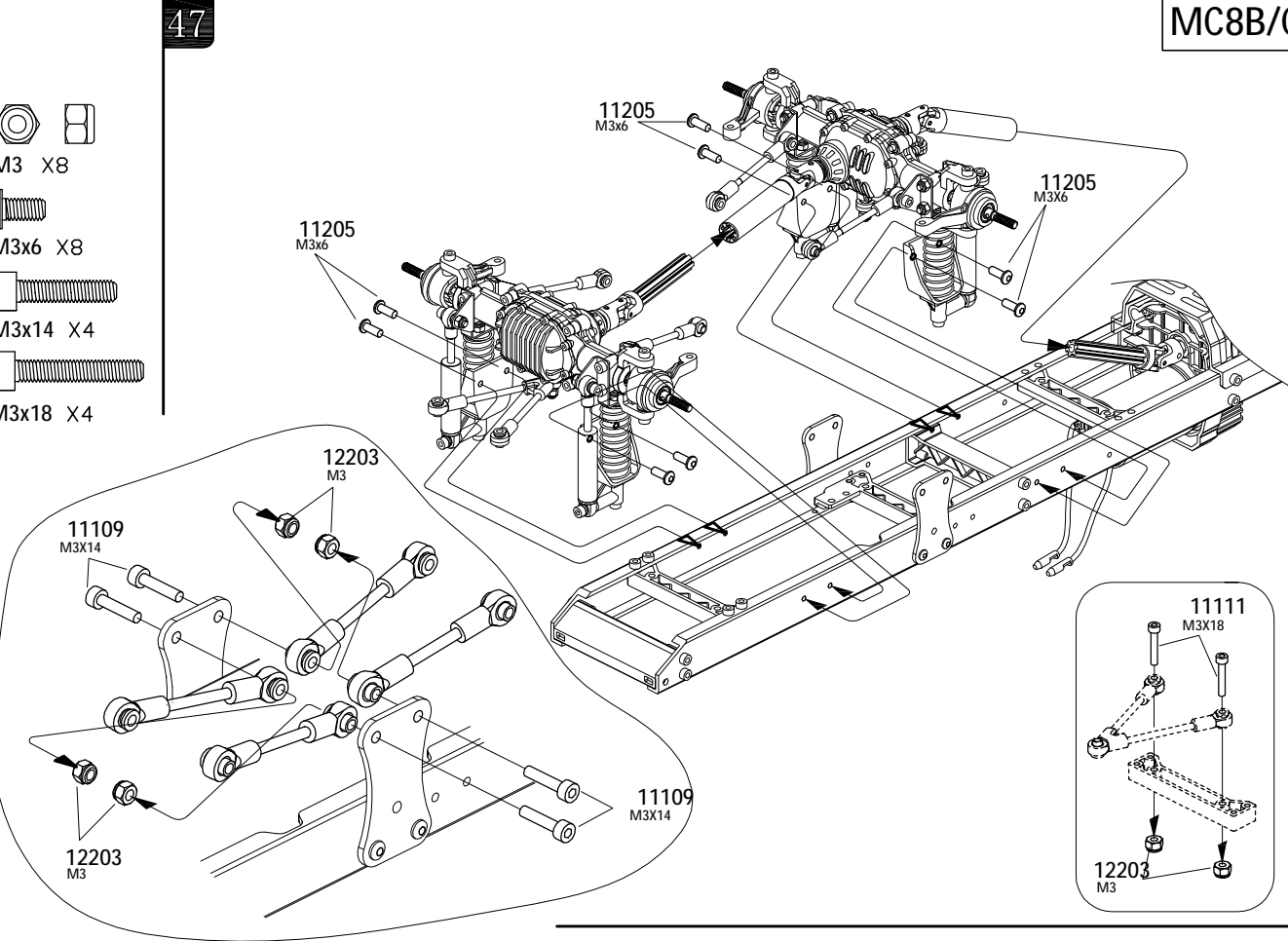
47

MC8B/C

- 12203  M3 X8
- 11205  M3x6 X8
- 11109  M3x14 X4
- 11111  M3x18 X4



- 12203  M3 X10
- 11205  M3x6 X2
- 11207  M3x10 X5
- 11210  M3x16 X2
- 11113  M3x22 X2
- 11122  M3x35 X2
- 14102  $\phi 3 \times \phi 7 \times 0.5$ X4

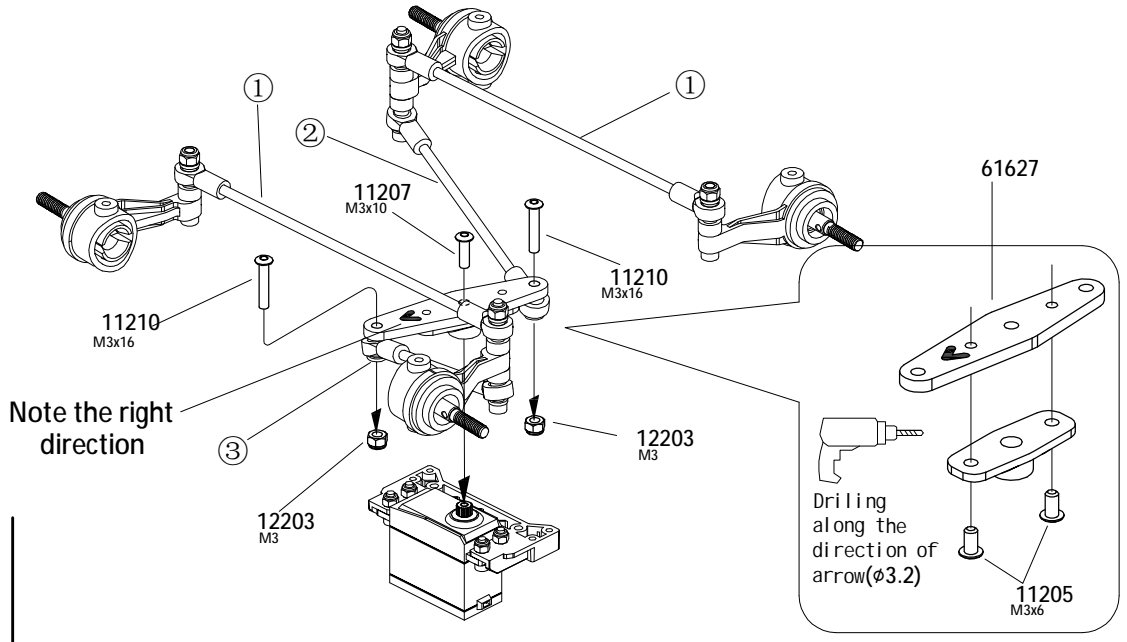
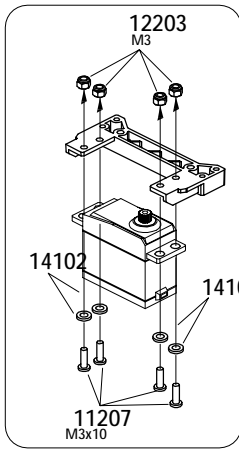
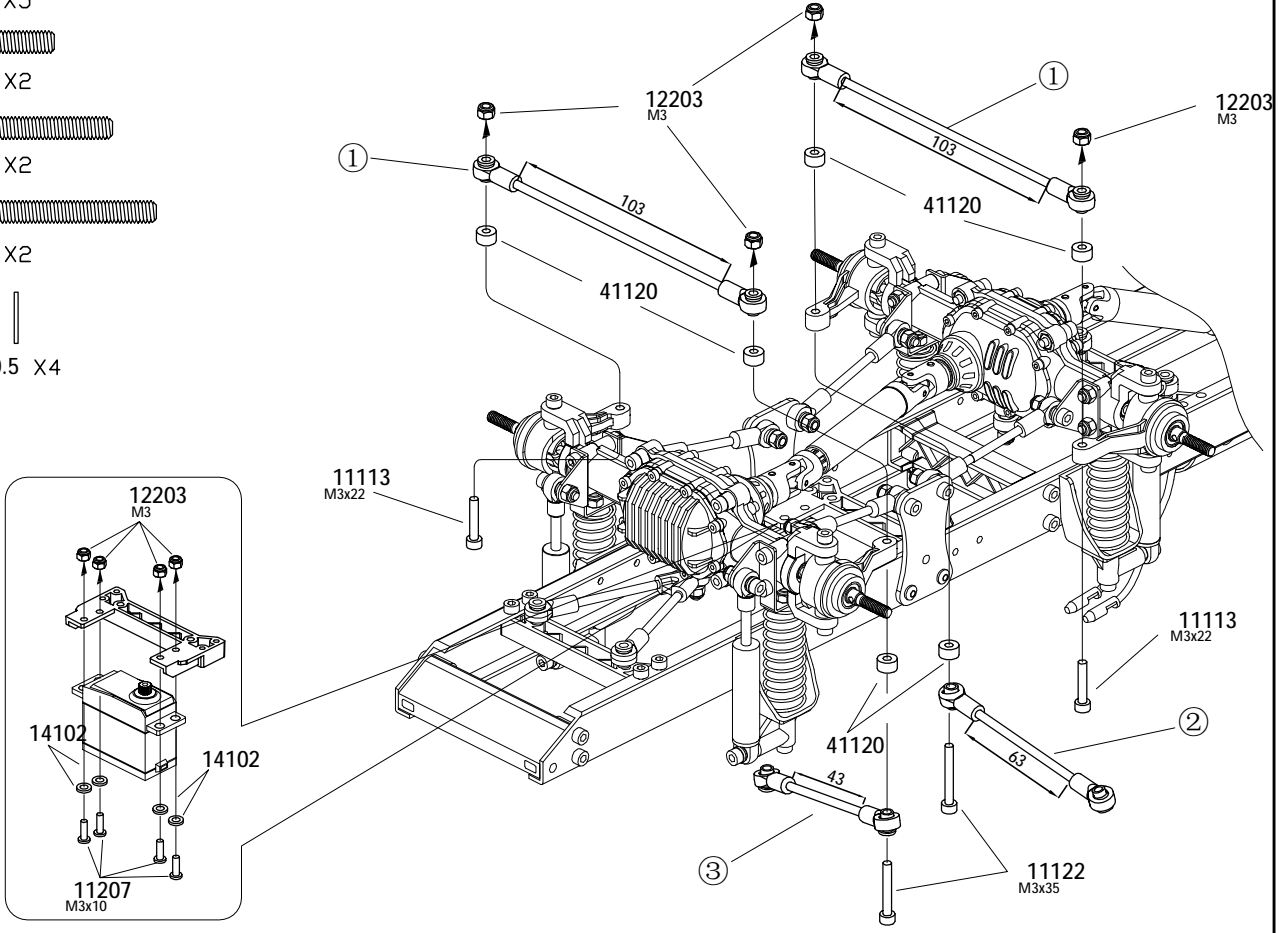
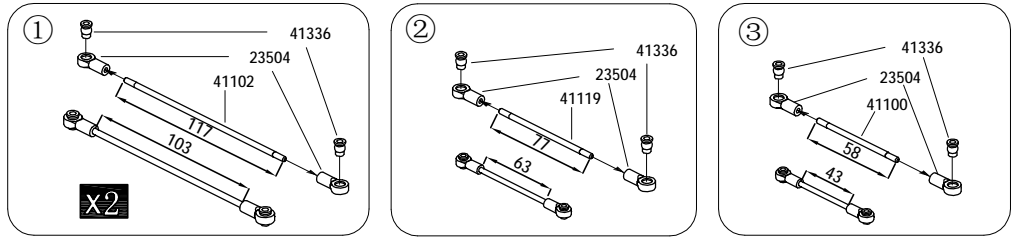

49

MC8B/C

12204
M4 X8

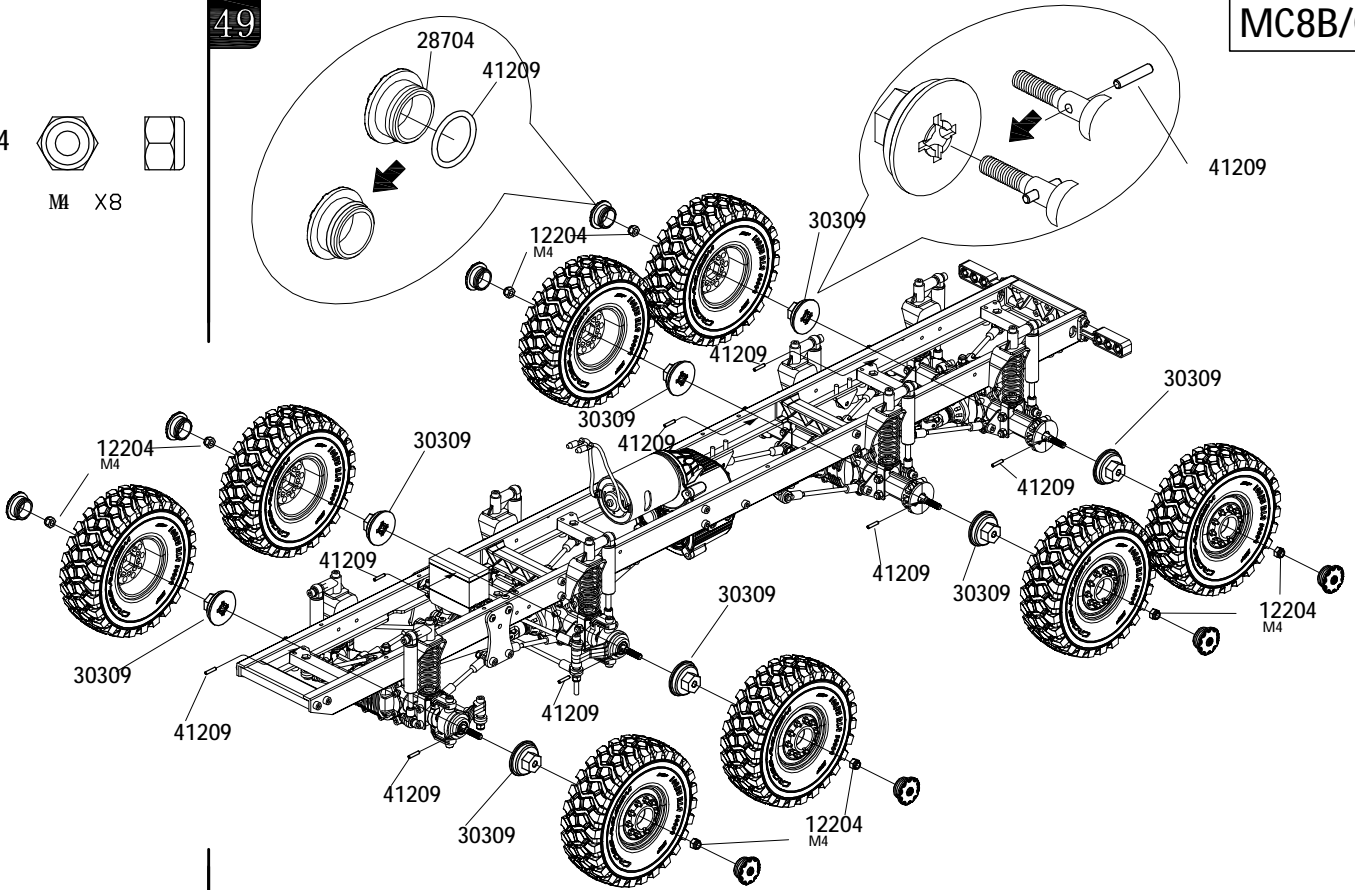

50

MC8B/C

11216
M2.5x6 X1

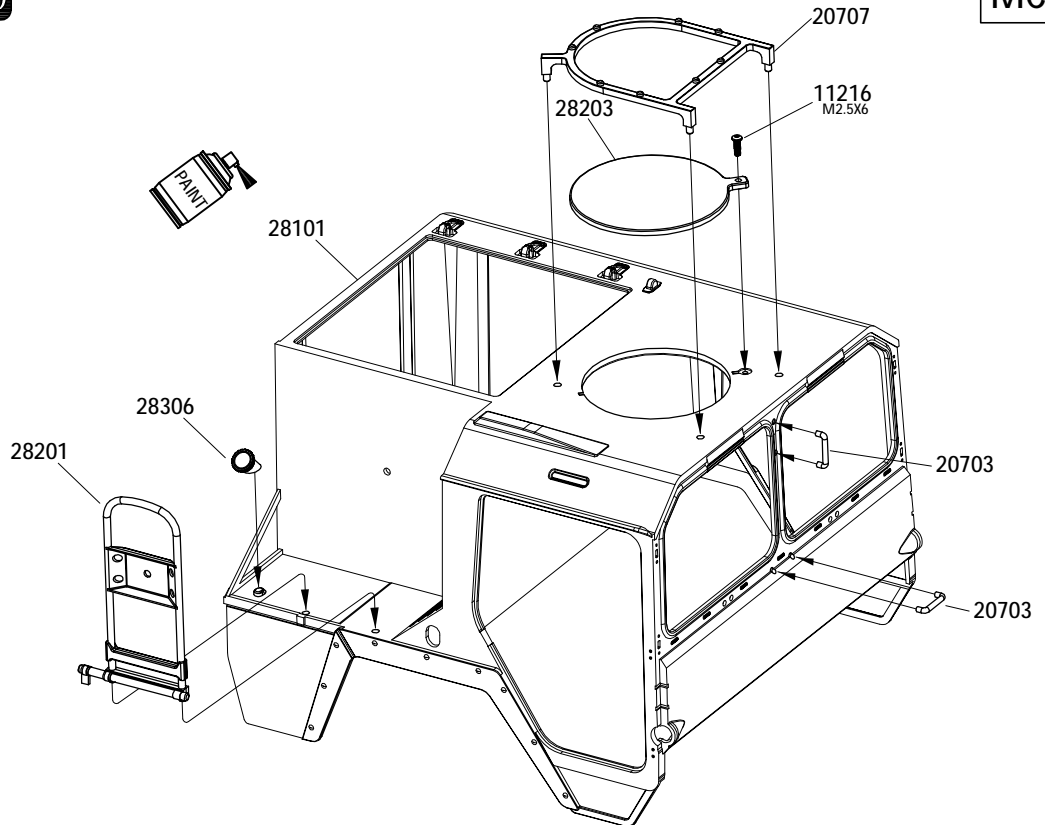
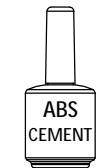

51

MC8B/C

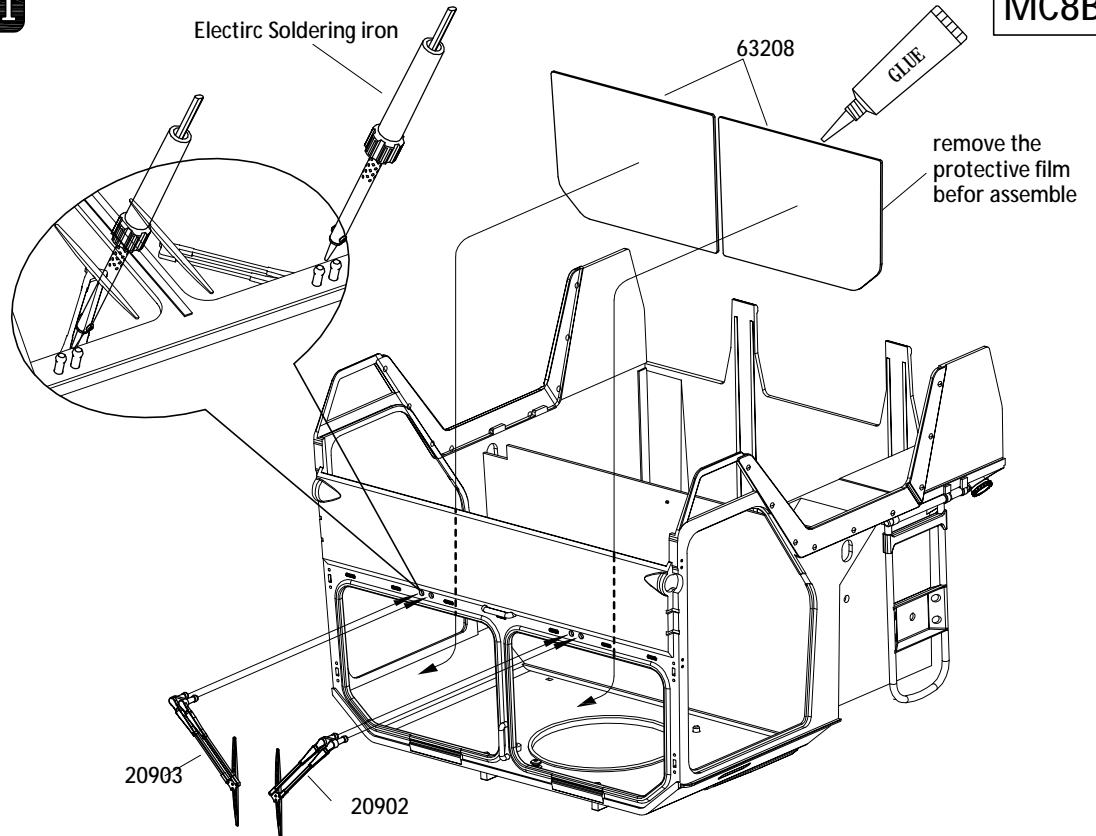

52

MC8B/C

12218 
M2.5x4 X2

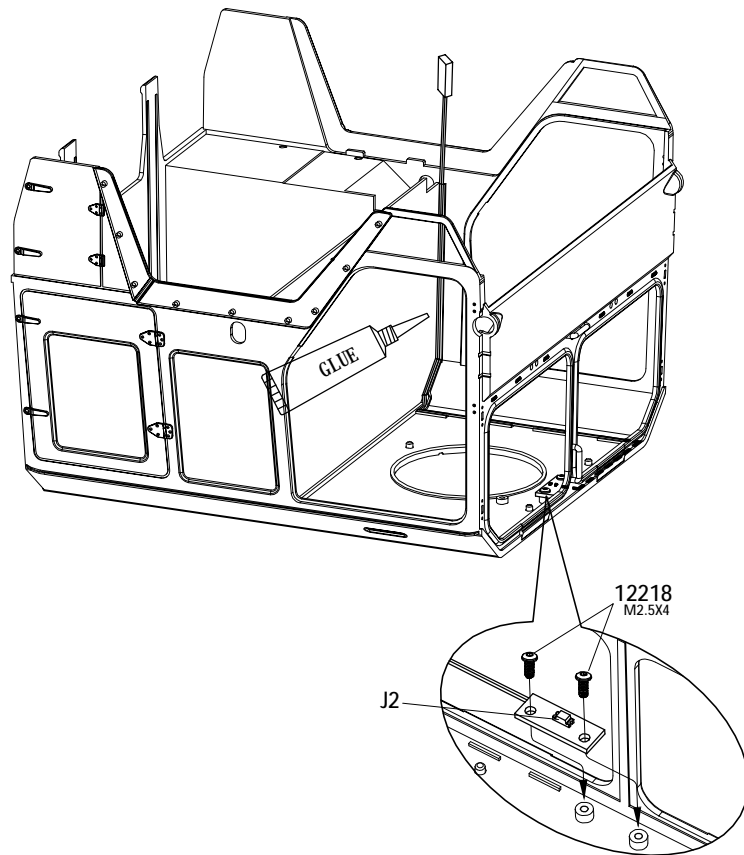
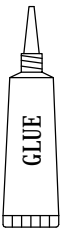

53

MC8B/C

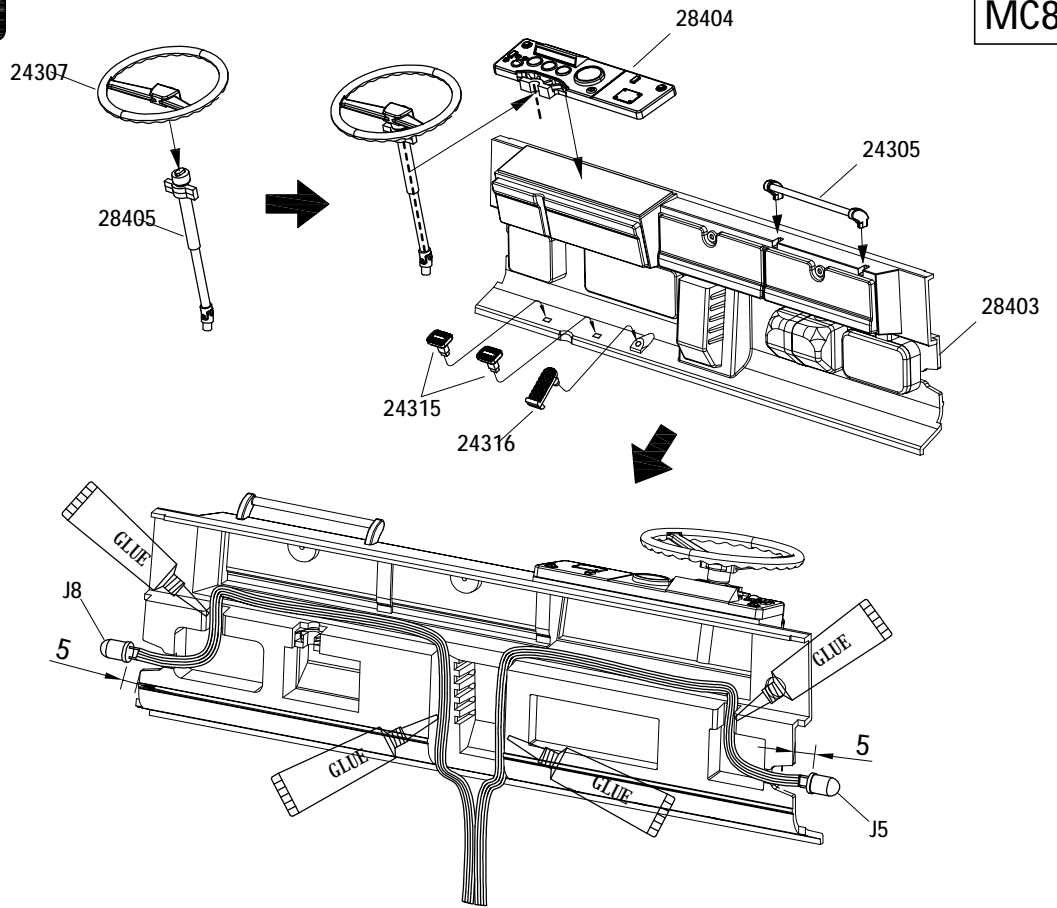

54

MC8B/C

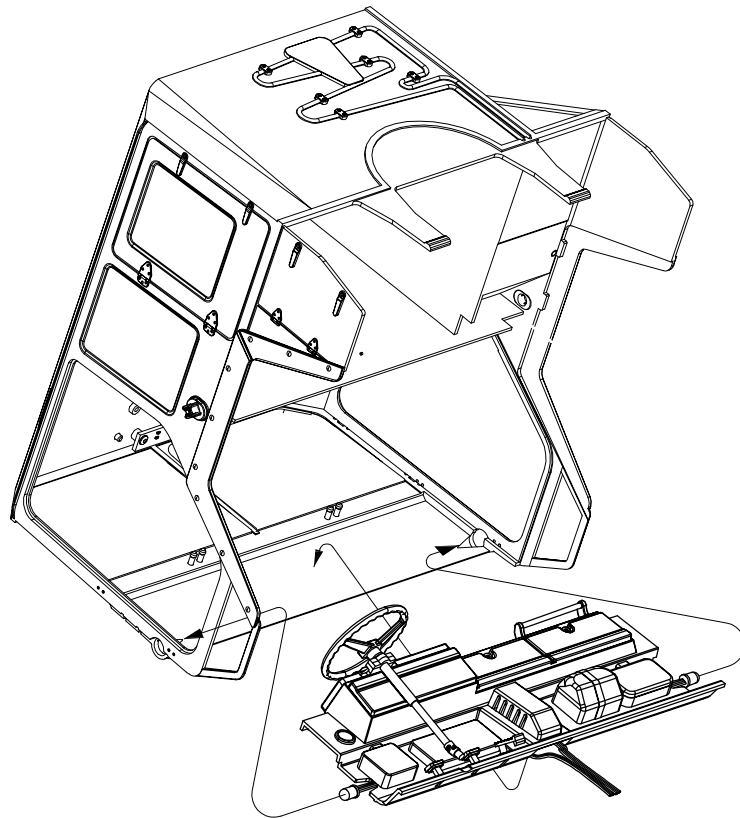
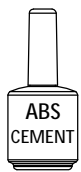

11205 
M3x6 X4

55

MC8B/C

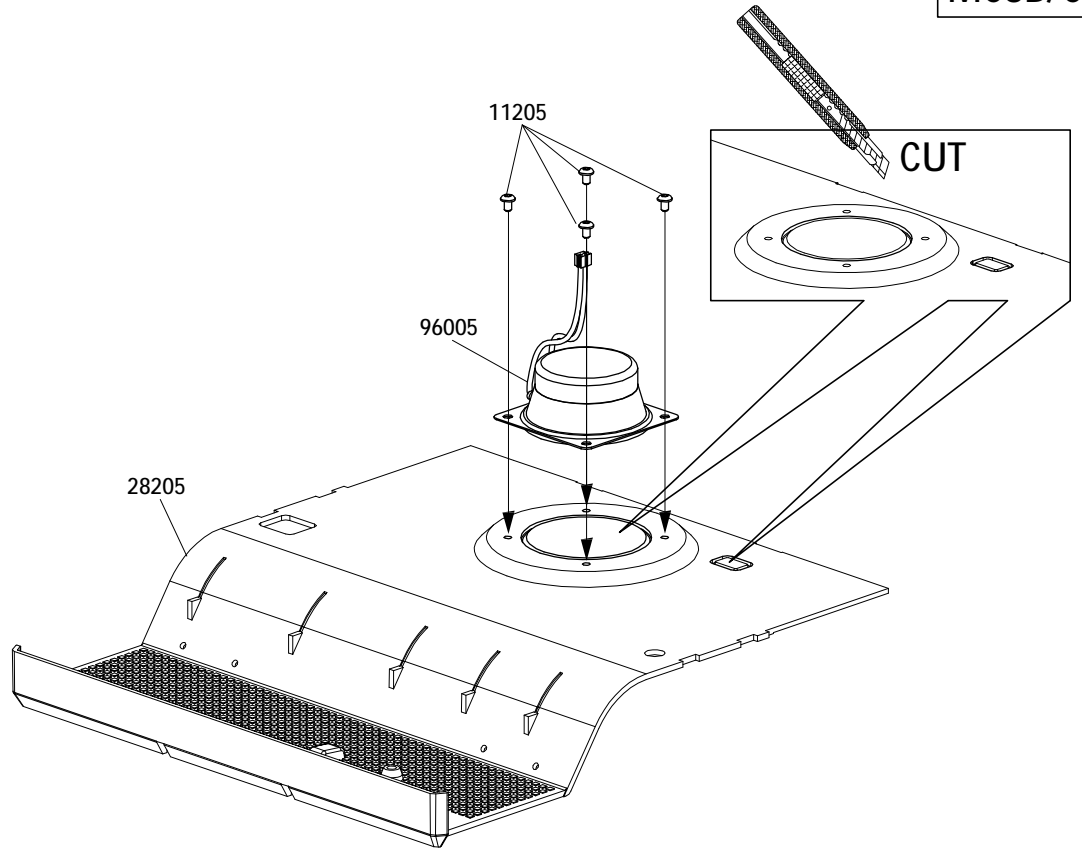

56

MC8B/C

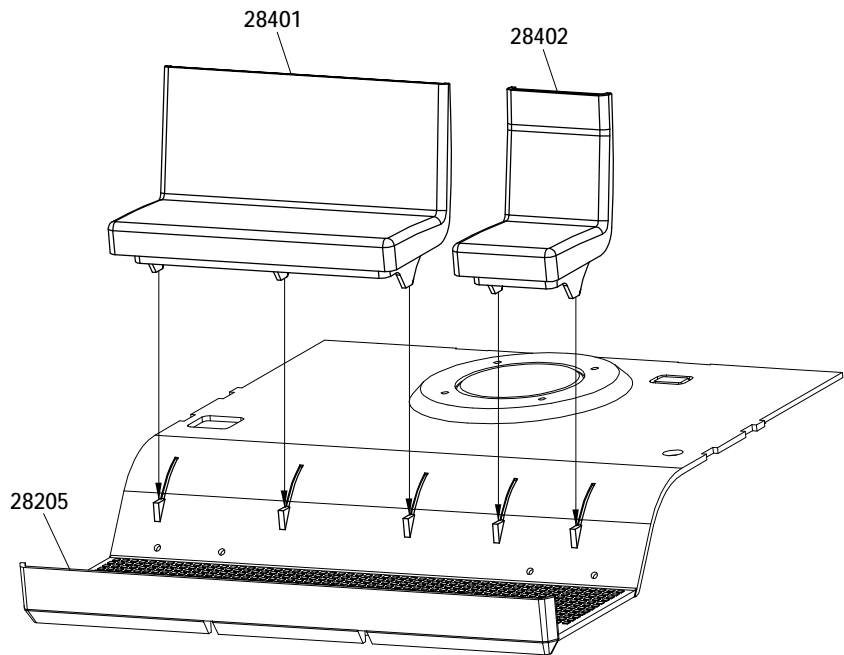

57

MC8B/C

12002  M2x10 X 4

12102  M2 X 4

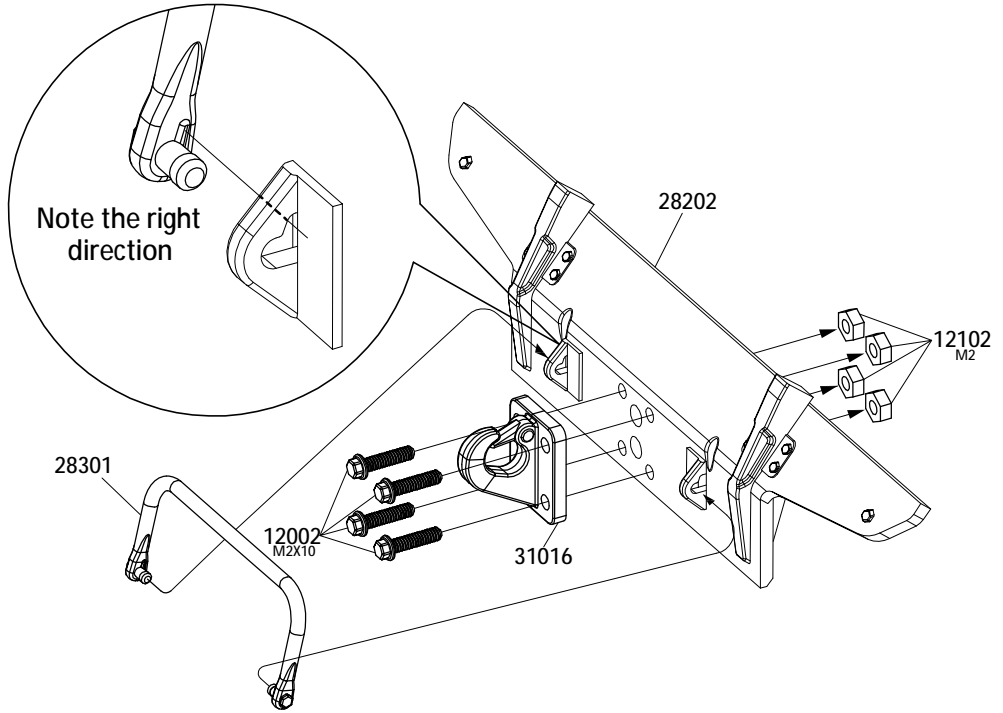

58

MC8B/C





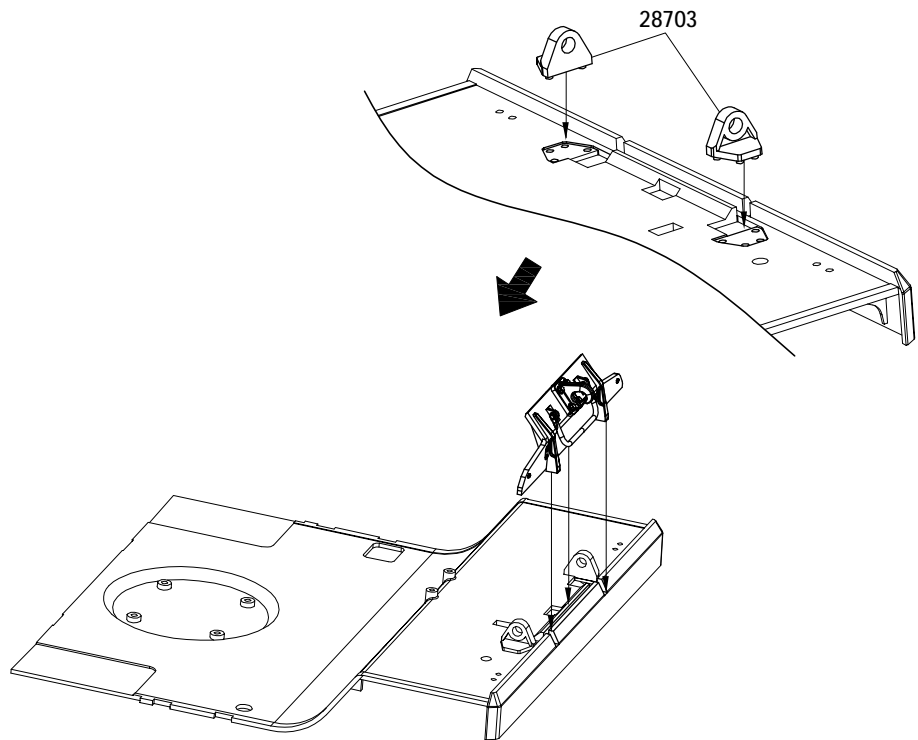

ABS
CEMENT



59

MC8B/C

- 11102  M2x6 X2
- 11205  M3x6 X2
- 11501  ST2.6x6 X4
- 11216  M2.5x6 X4
- 12105  M2.5 X4

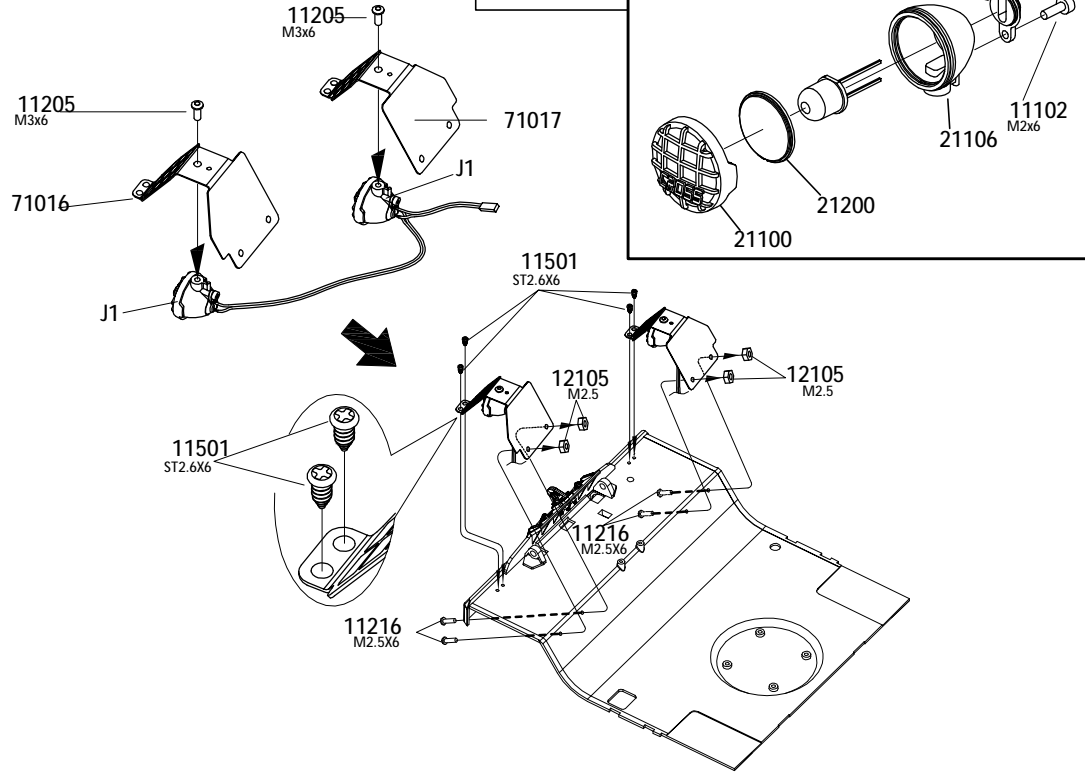

60

MC8B/C

- 11218  M2.5x4 X2

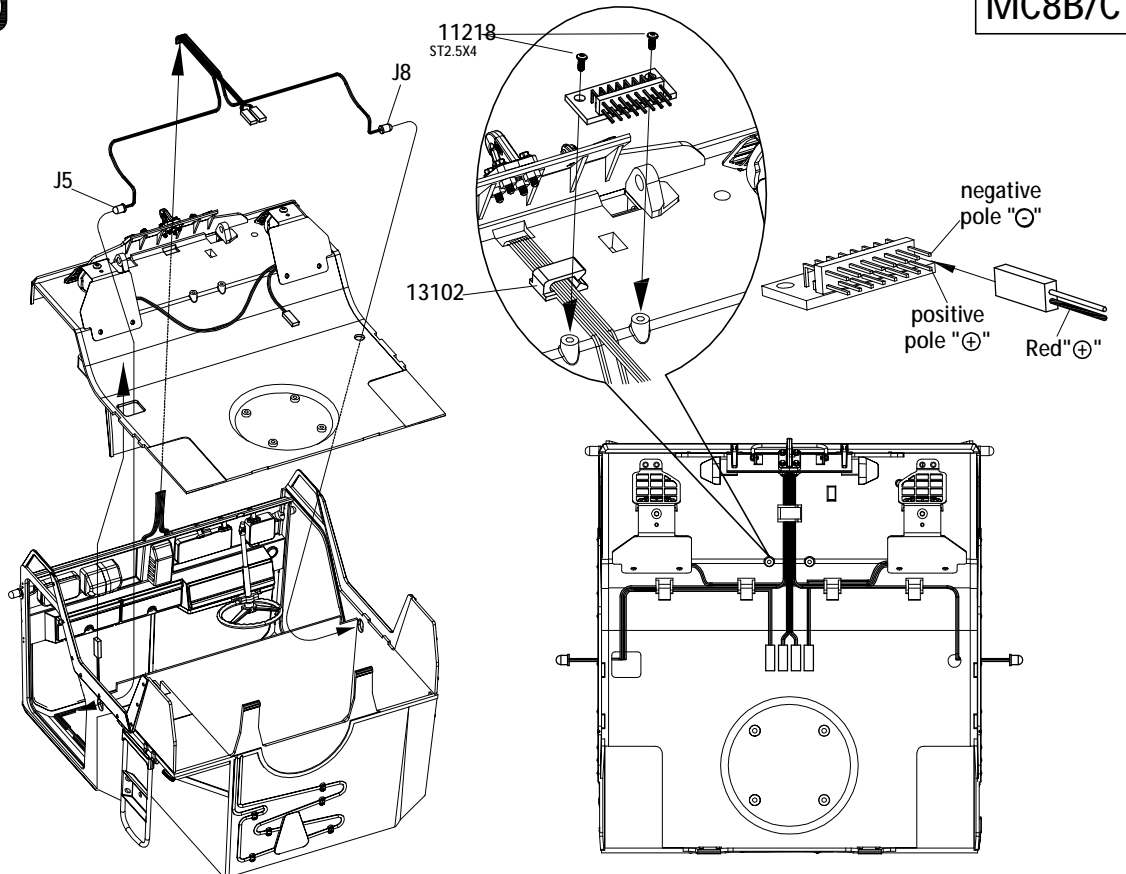

61

MC8B/C

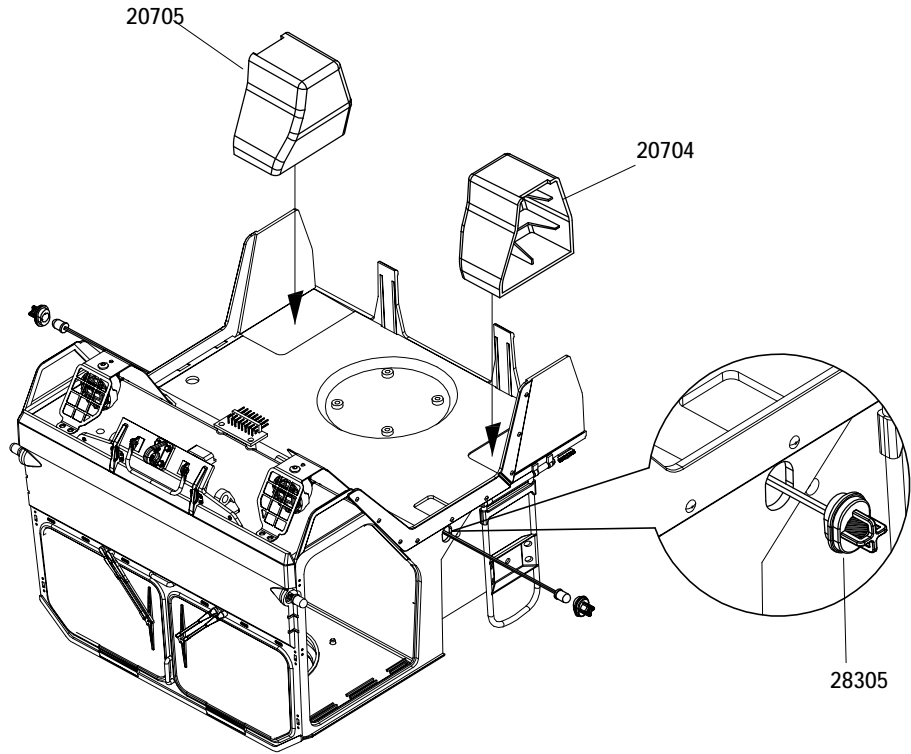

62

MC8B/C

11802  ST1.4x4 X6

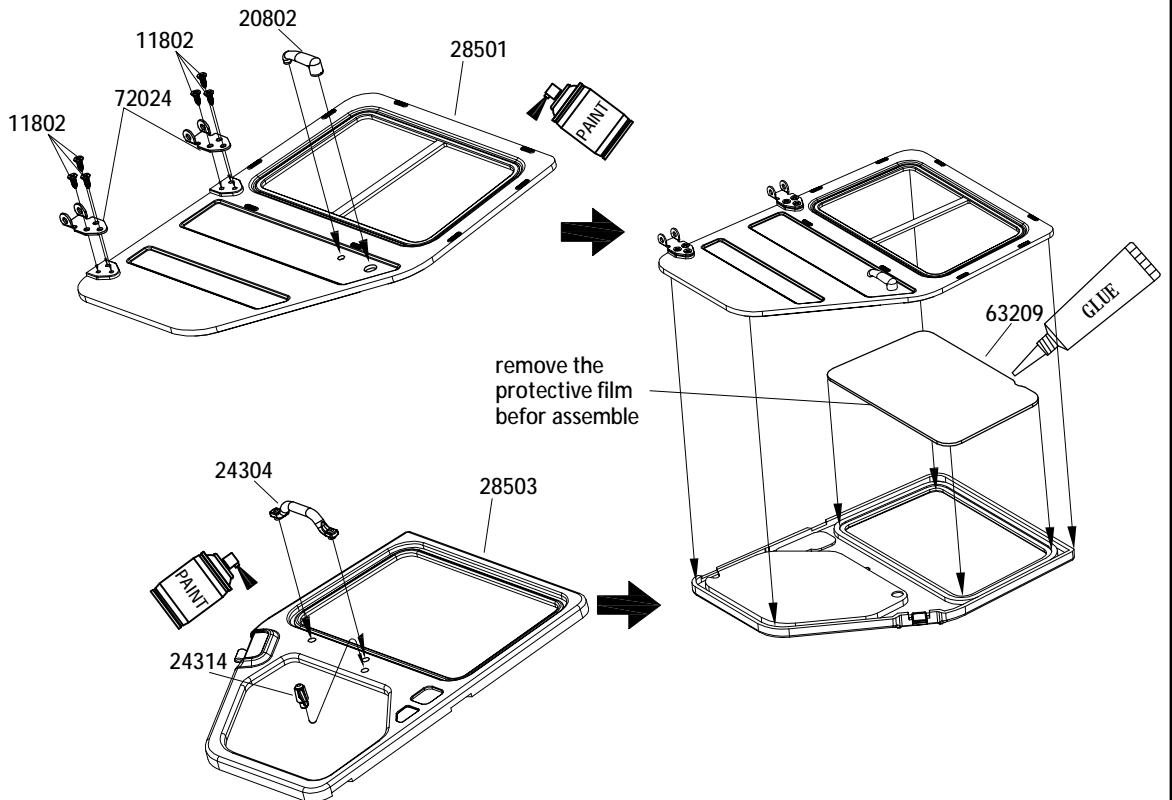
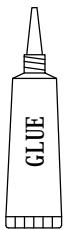

63

MC8B/C

11802  ST1.4x4 X6

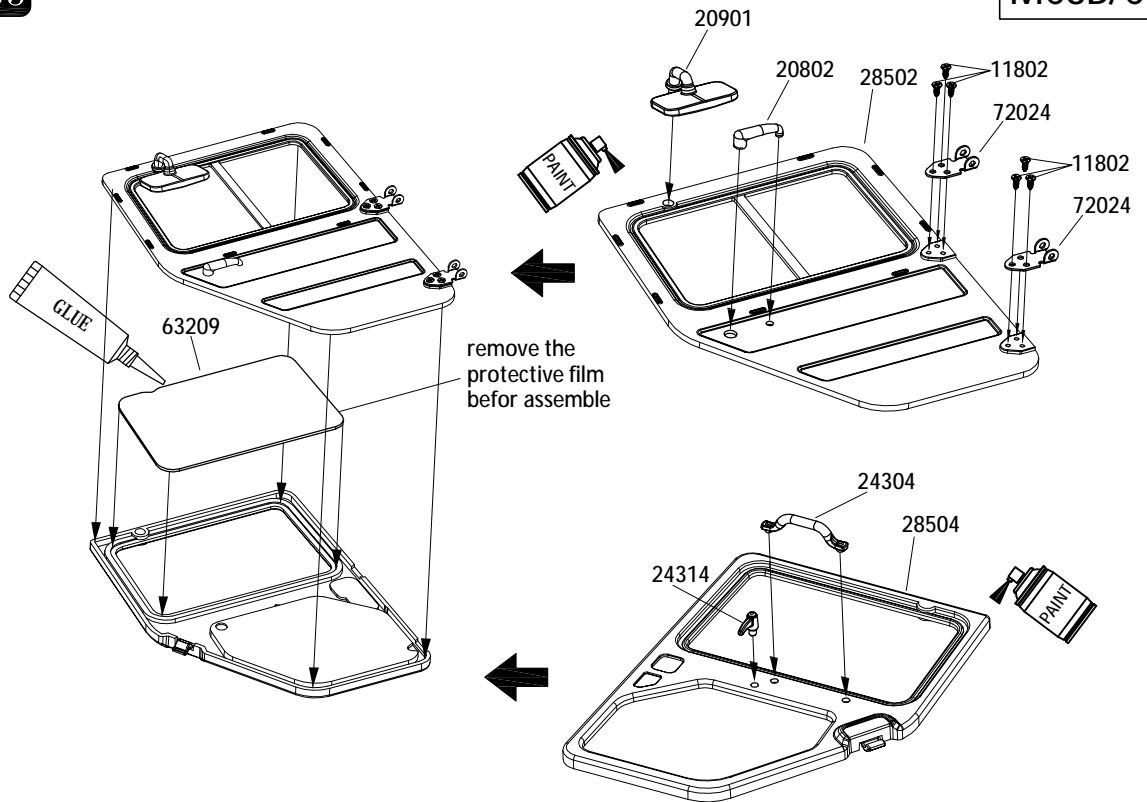
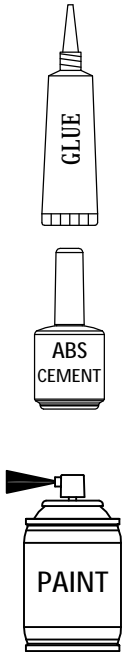

64

MC8B/C

11802  ST1.4x4 X8

11707  M1.6X10X4

12106  M1.6 X4

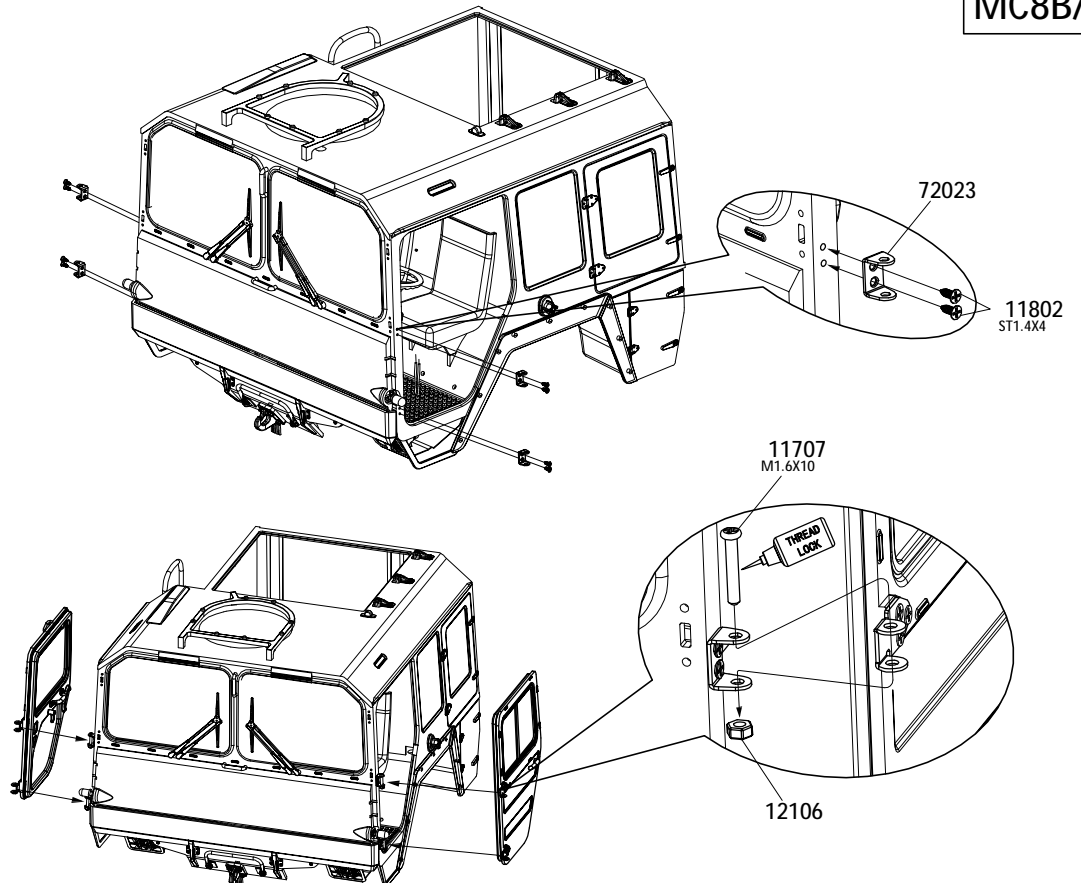

MC8B/C

11801  ST1.4x6 X8

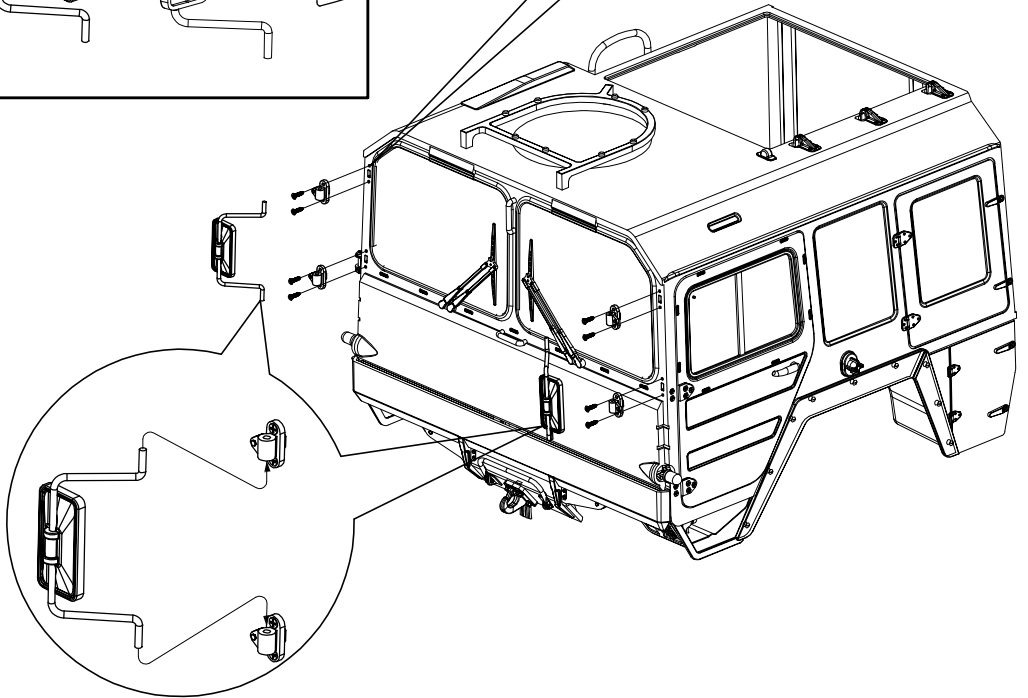
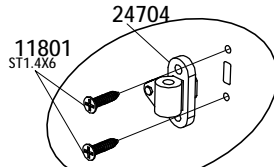
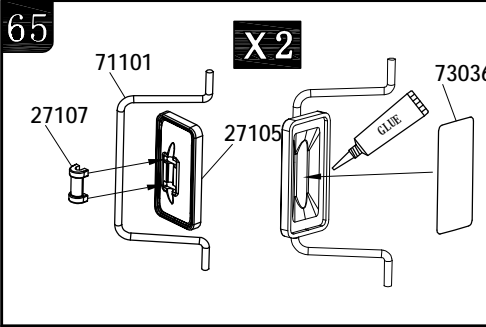

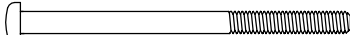

66

MC8B/C

11701  M3x45 X1

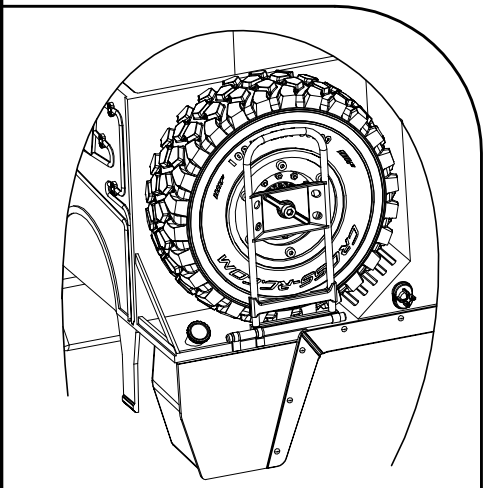
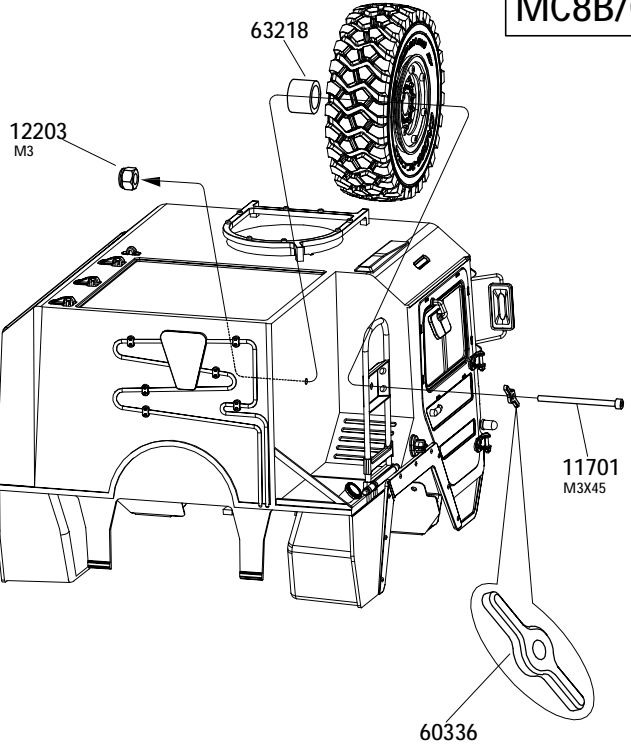
12203  M3 X1



11801  ST1.4x6 X1

67

MC8B/C

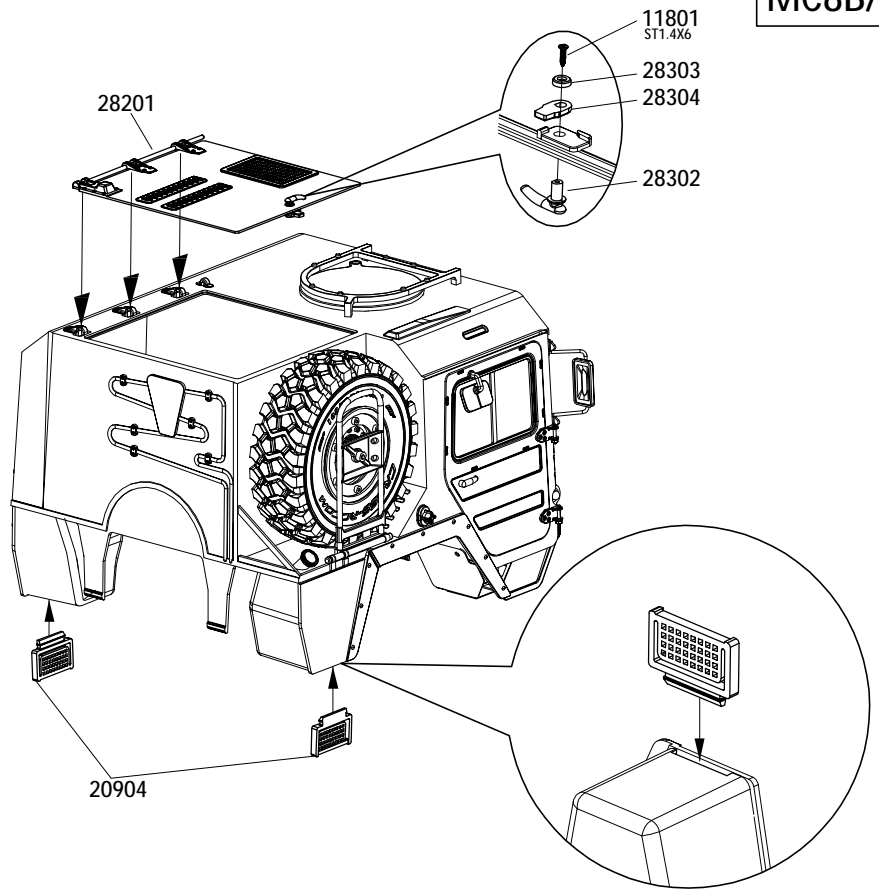

68

MC8B/C

-  ABS CEMENT
-  28307
-  28308

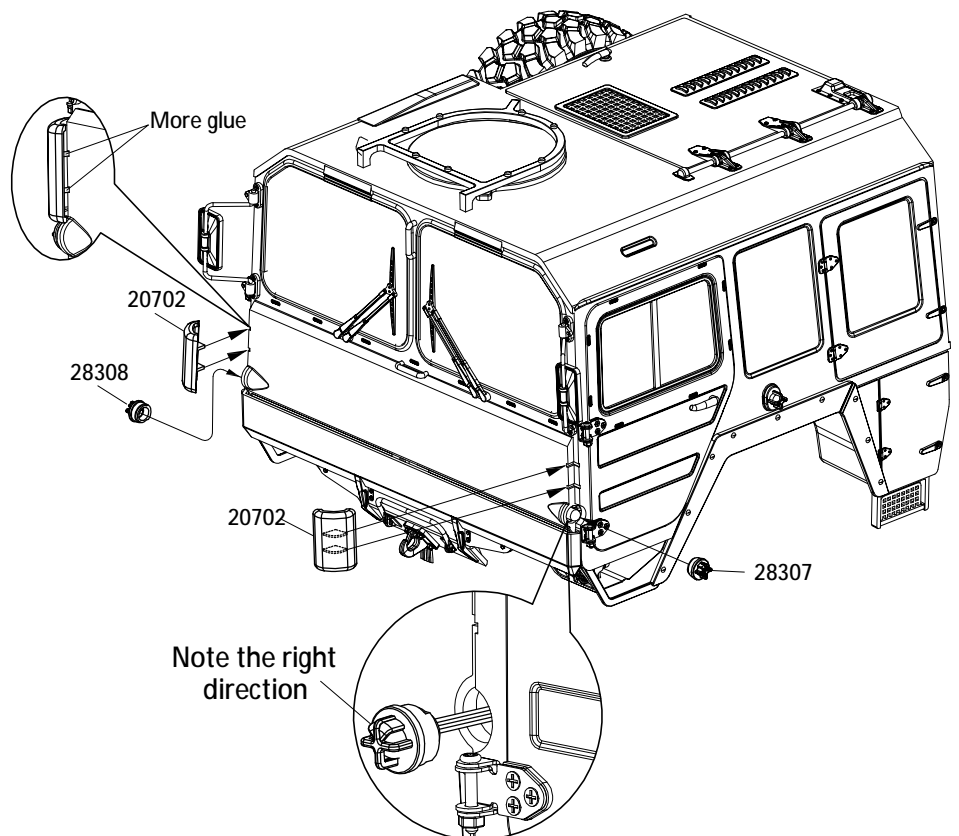

69

MC8B/C



Note the right direction

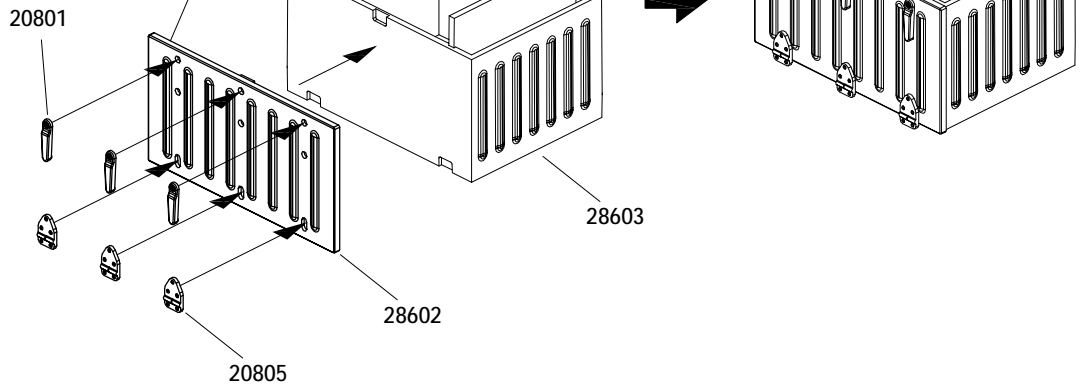

x2

70

MC8B/C

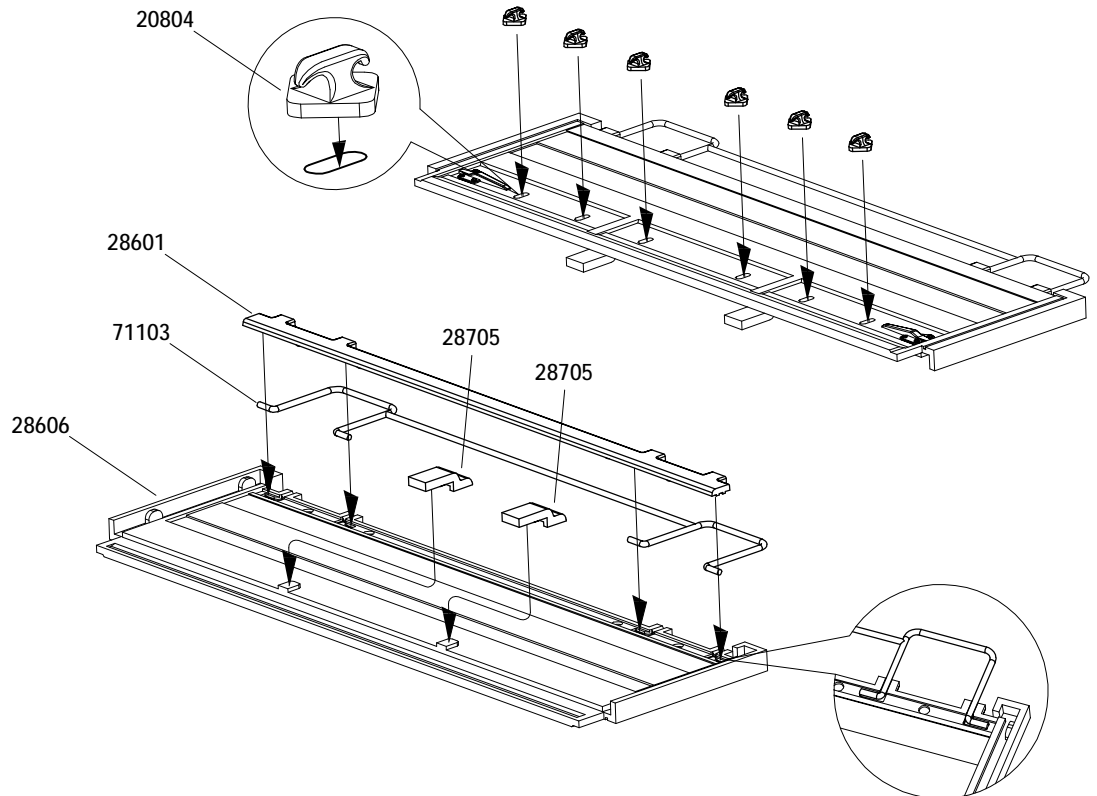
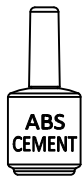

71

MC8B/C

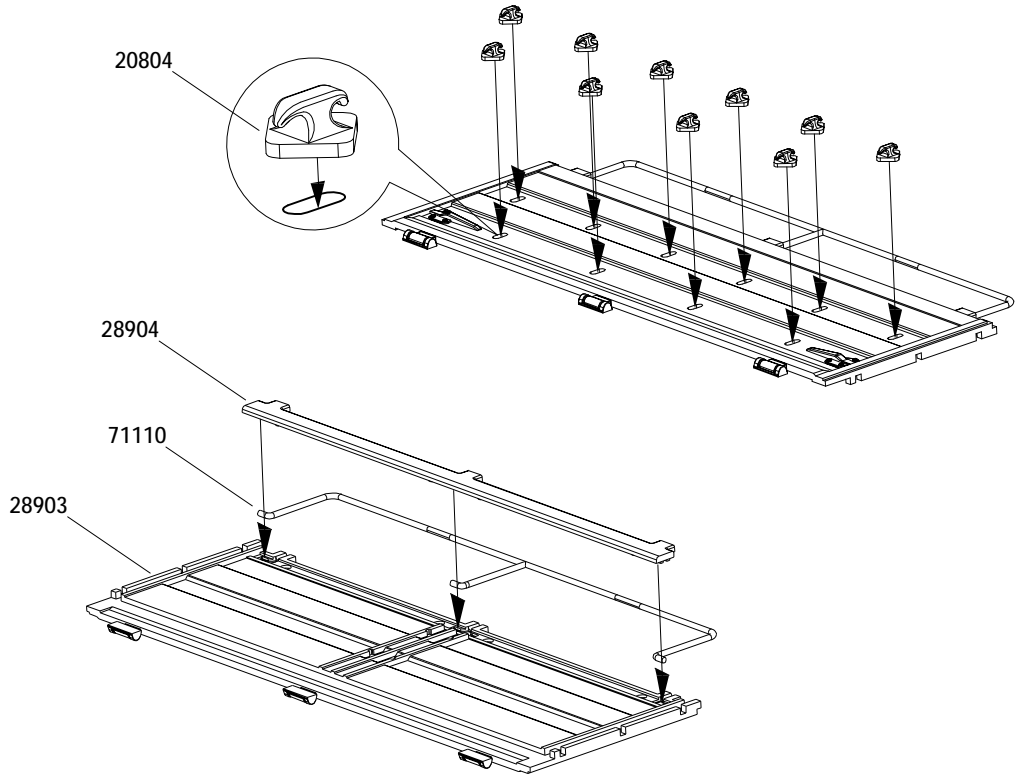

X6

72

MC8B/C

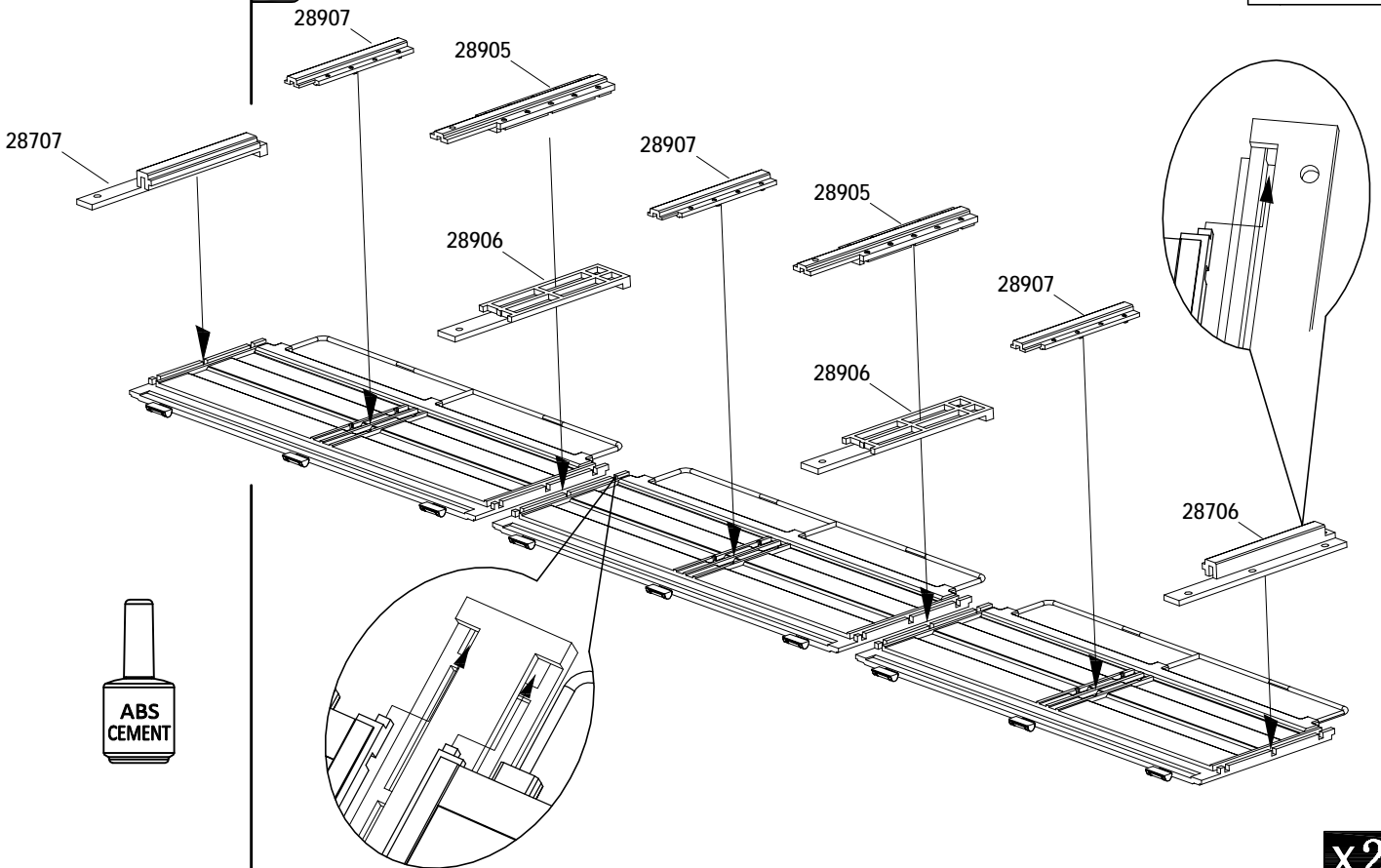

X2

73

MC8B/C

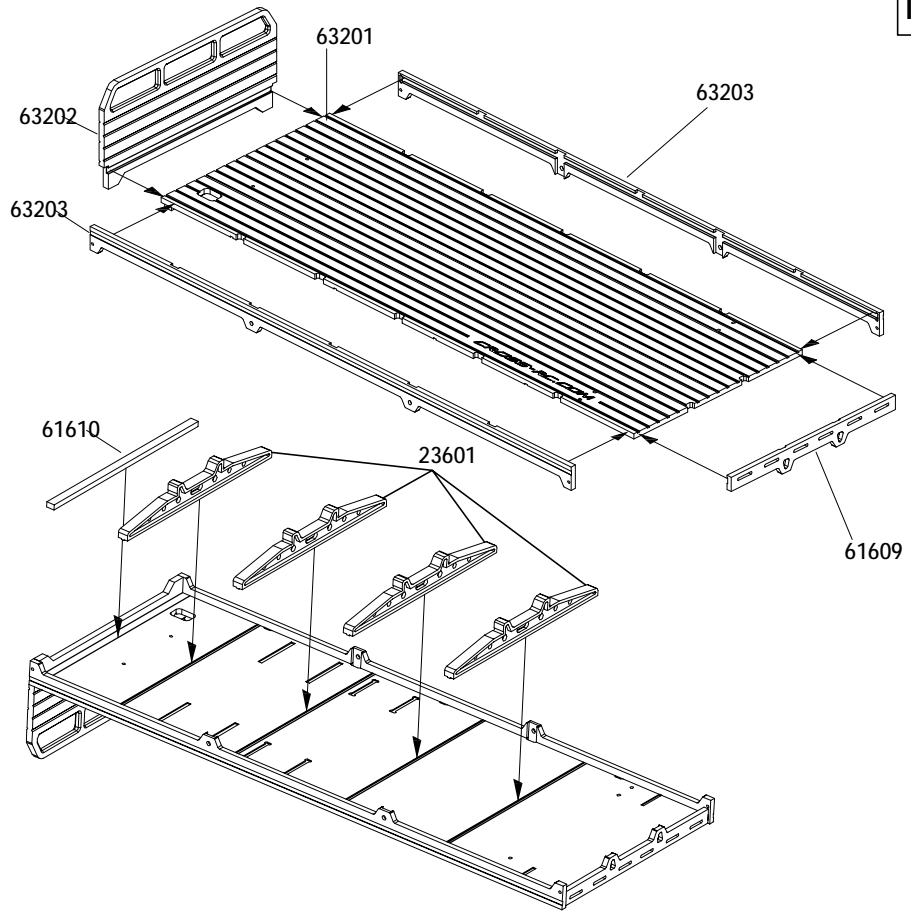

74

MC8B/C

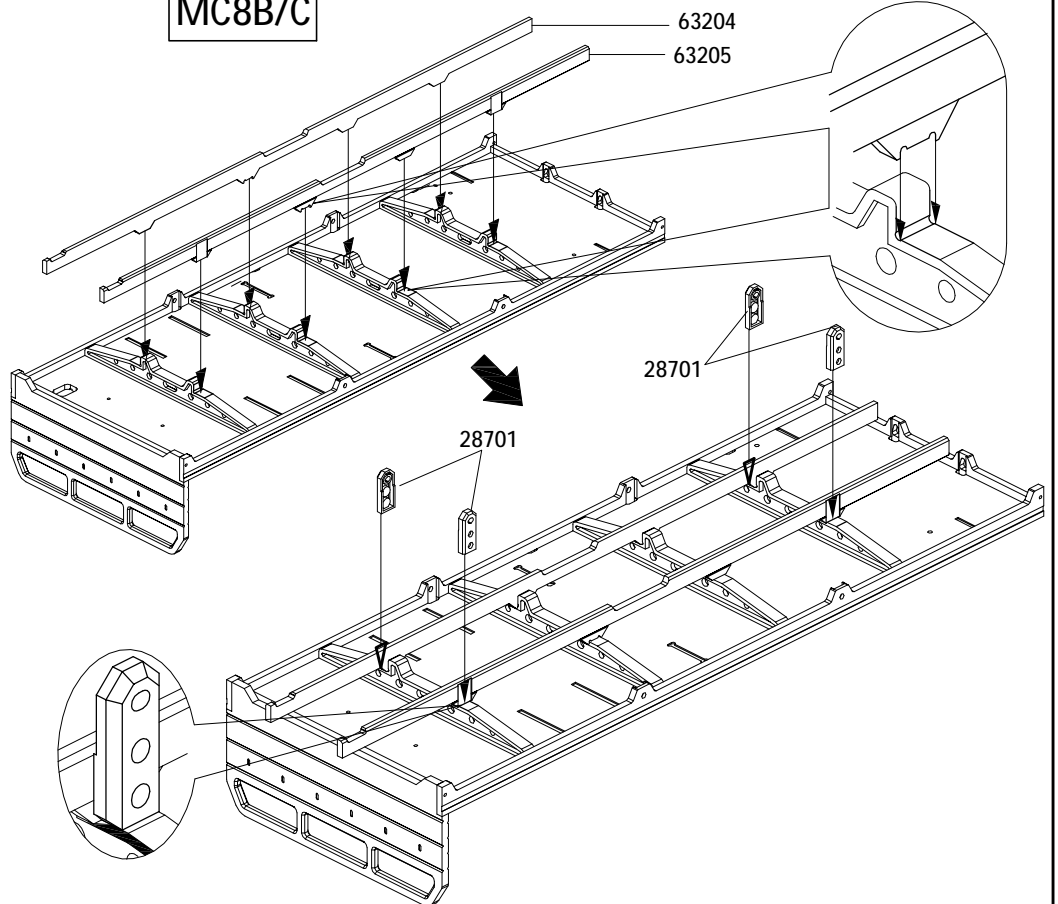
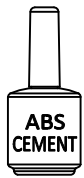

75

MC8B/C

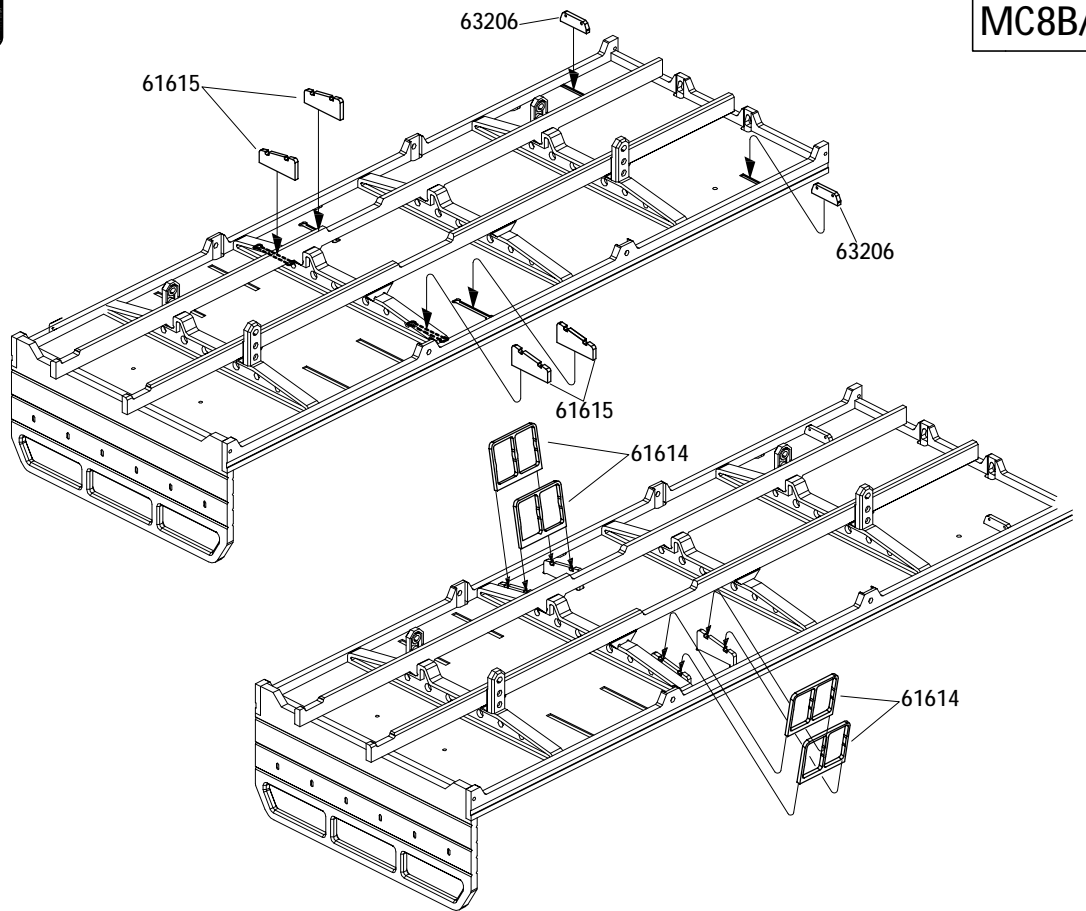

76

MC8B/C

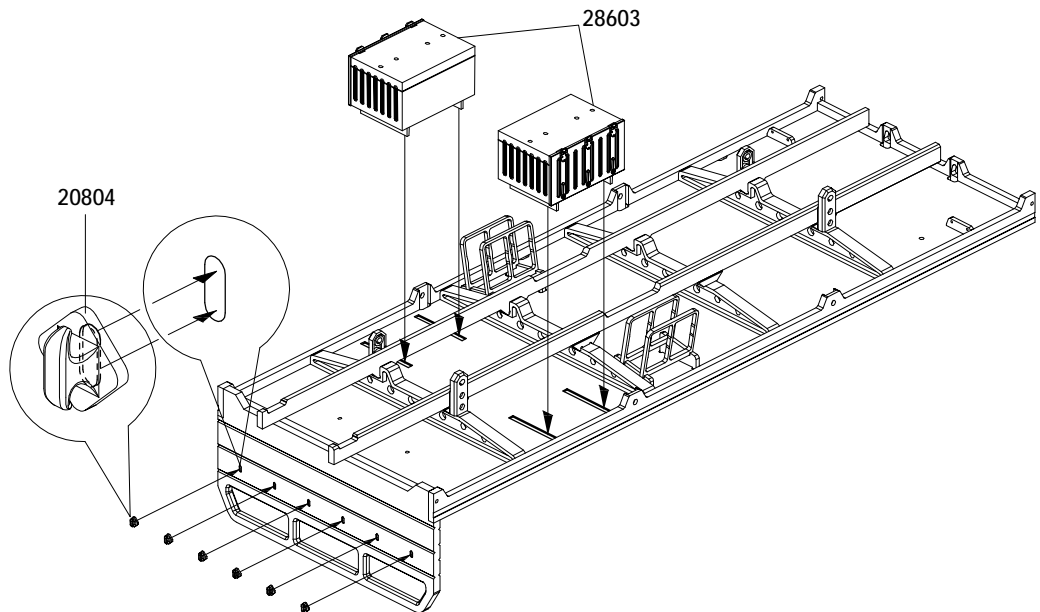
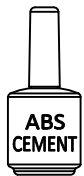

77

MC8B/C

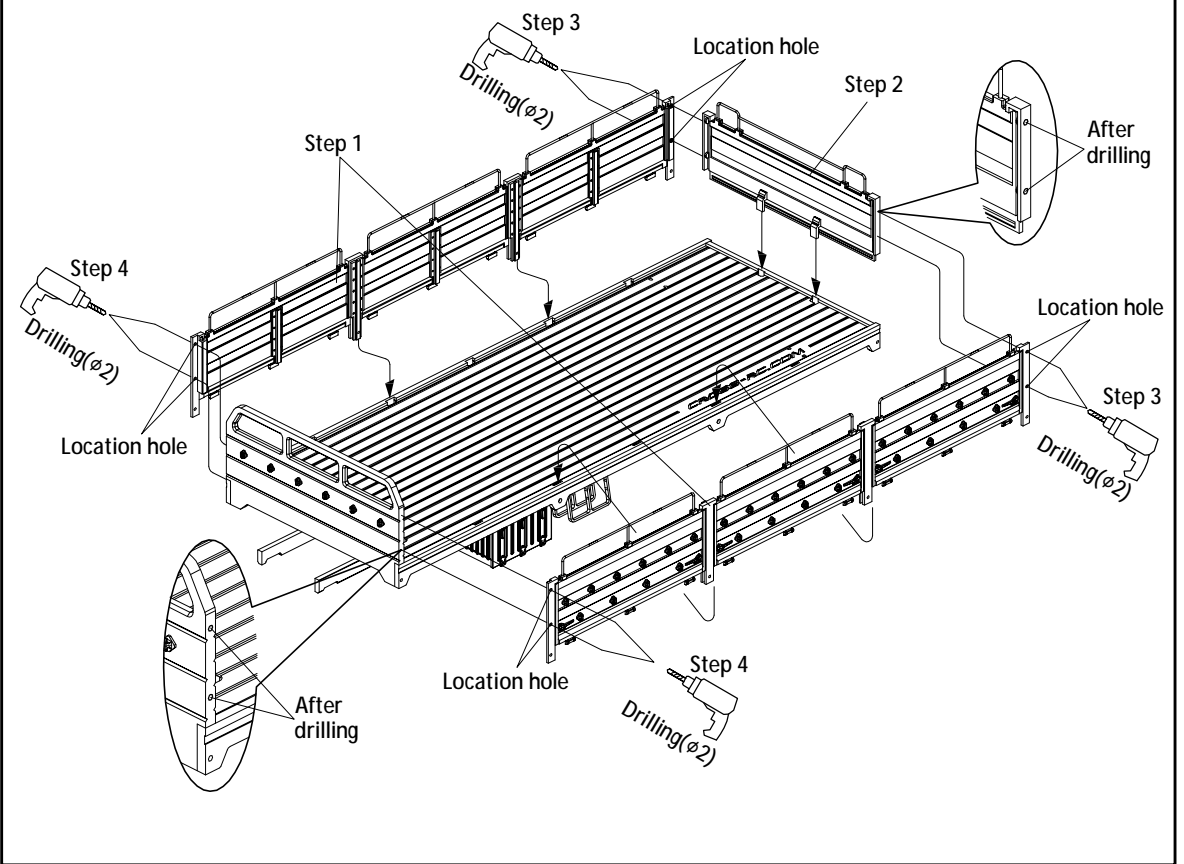

78

MC8B/C

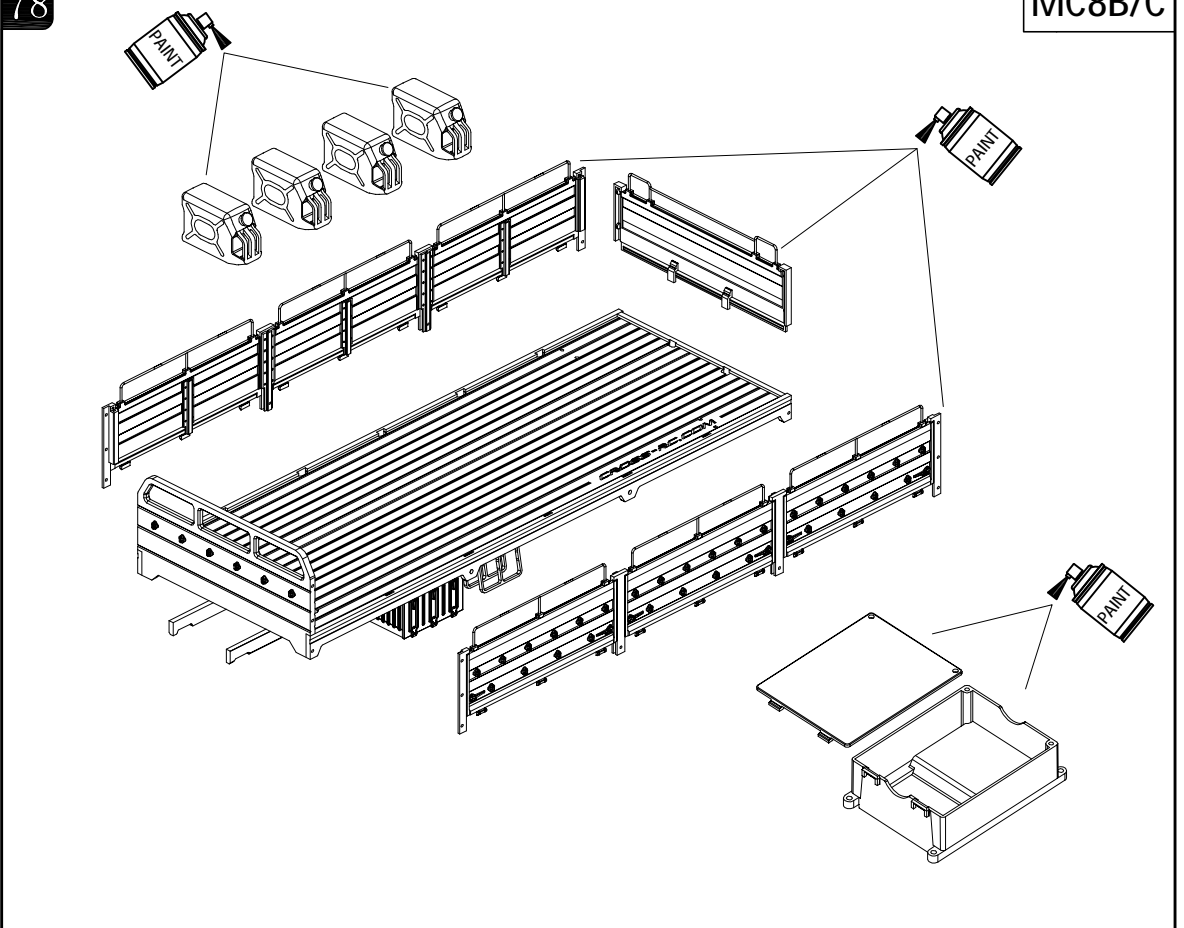

79

MC8B/C

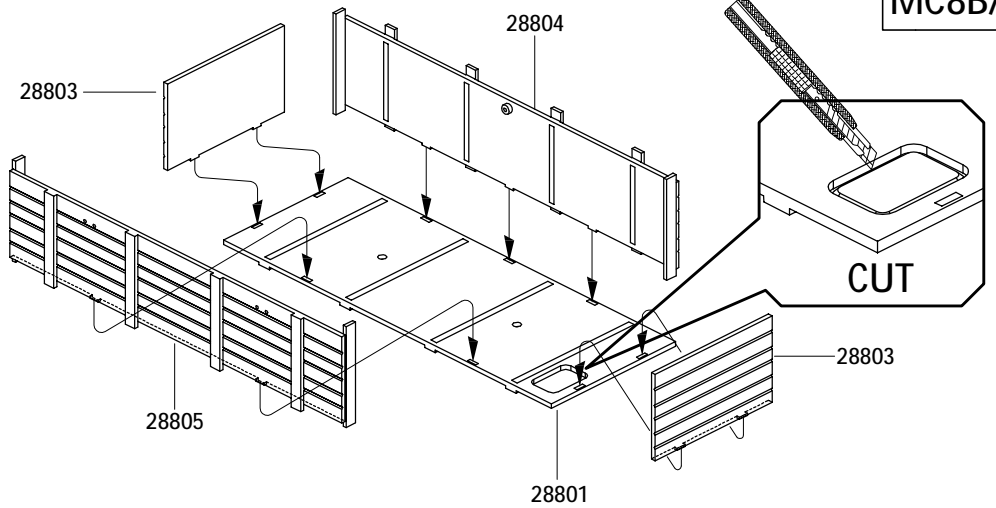
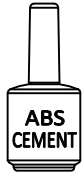

80

MC8B/C

11802  ST1.4x4 X8

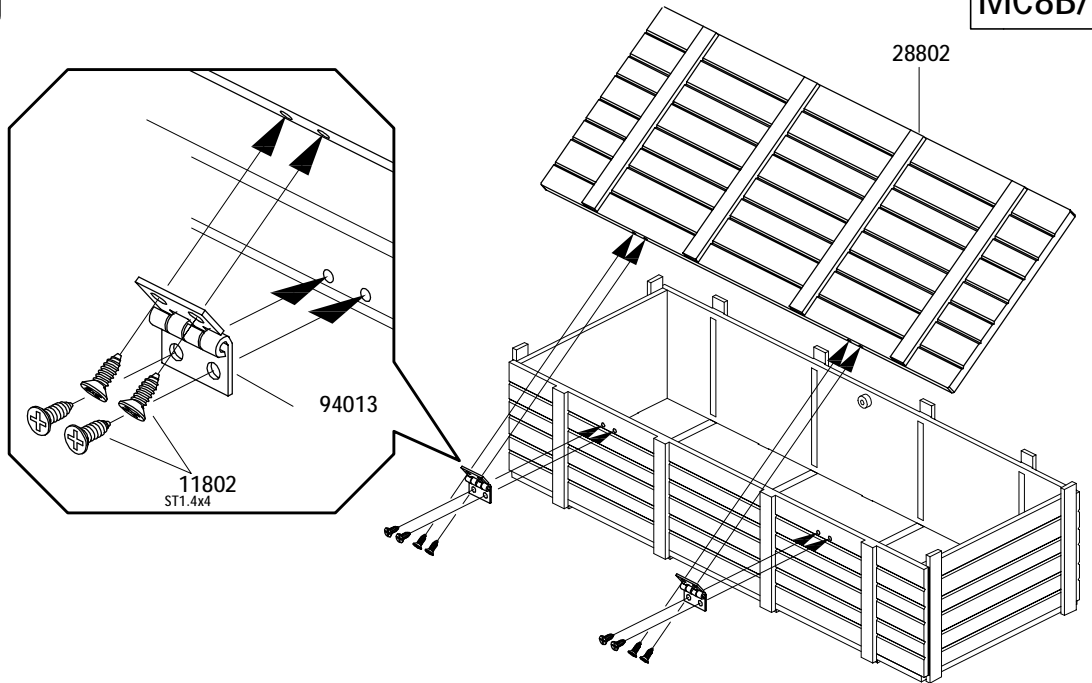

81

MC8B/C

11704  M1.6x6 X2

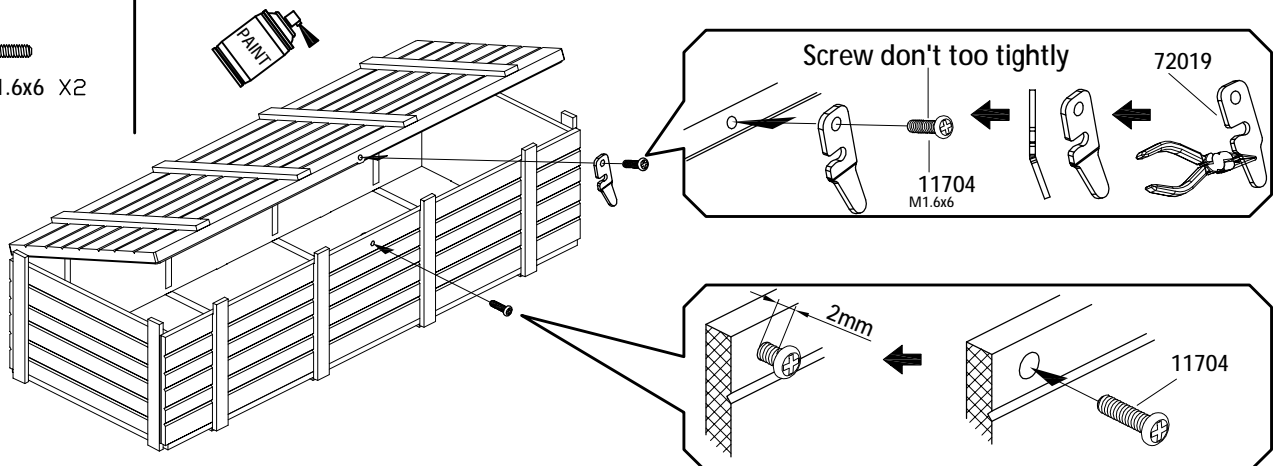

82

MC8B/C

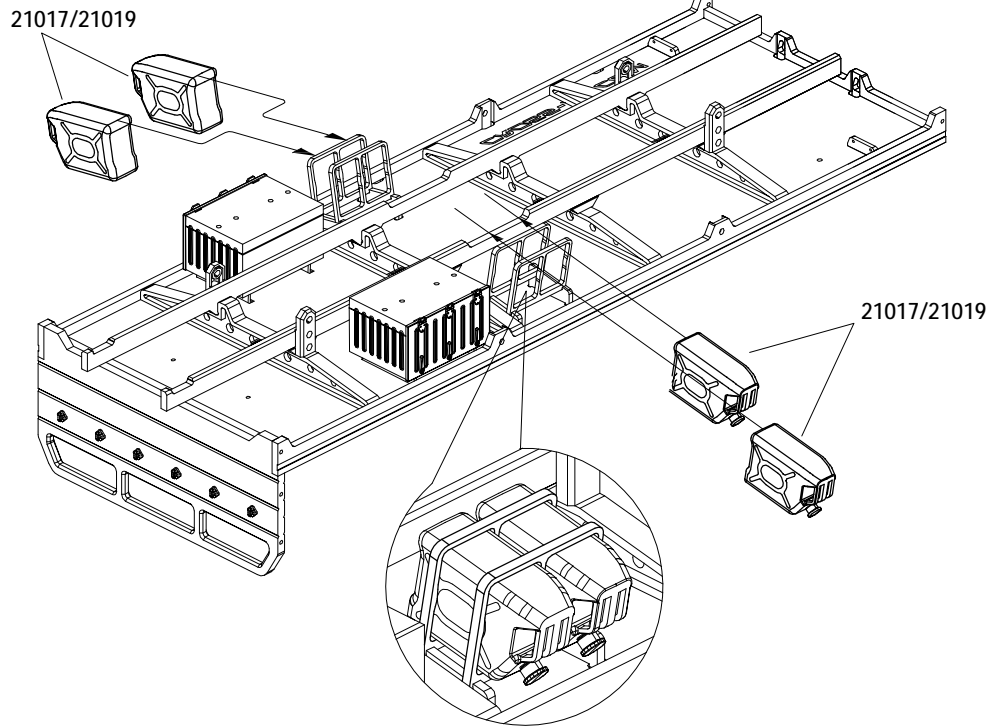

83

MC8B/C

- 11102  M2x6 X4
- 12001  M2x6 X6
- 11207  M3x10 X4
- 12203  M3 X4
- 12102  M2 X6

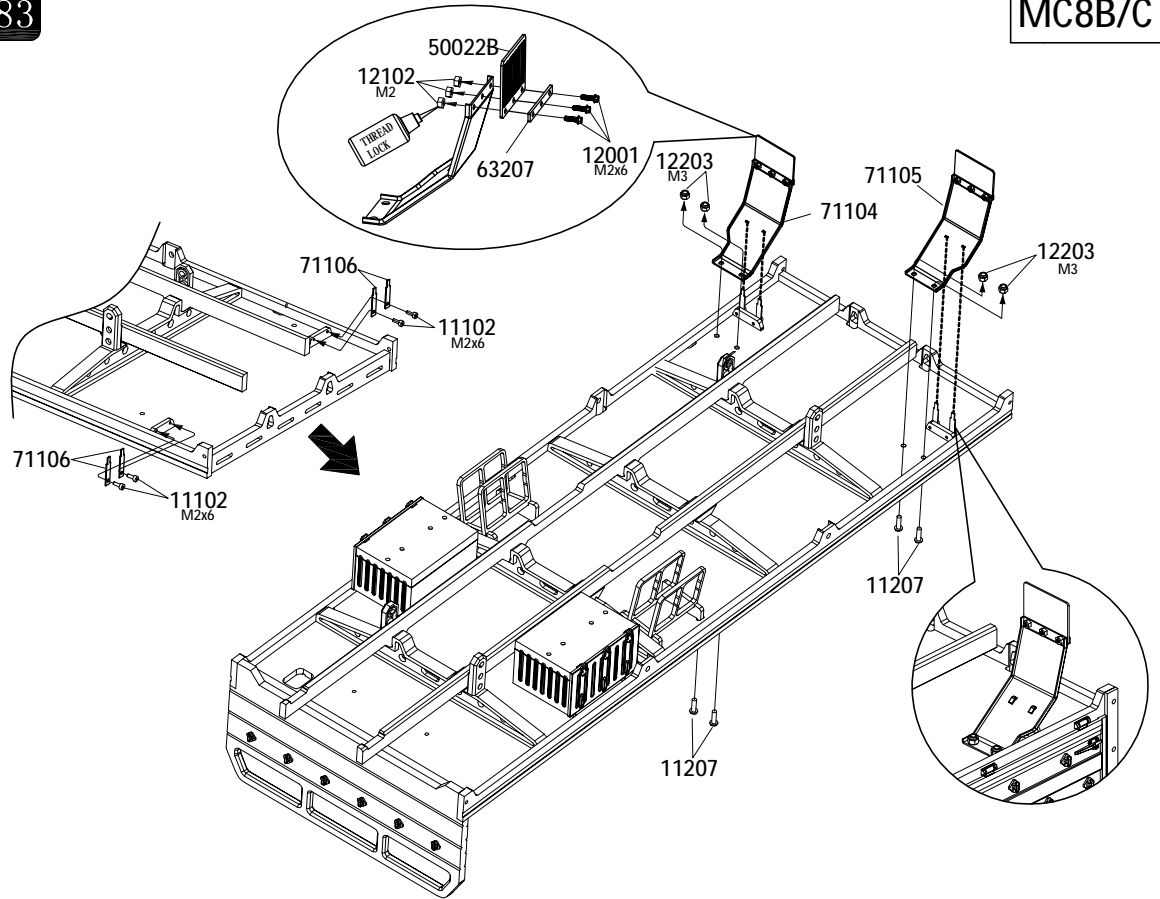



11207 
M3x10 X2

84

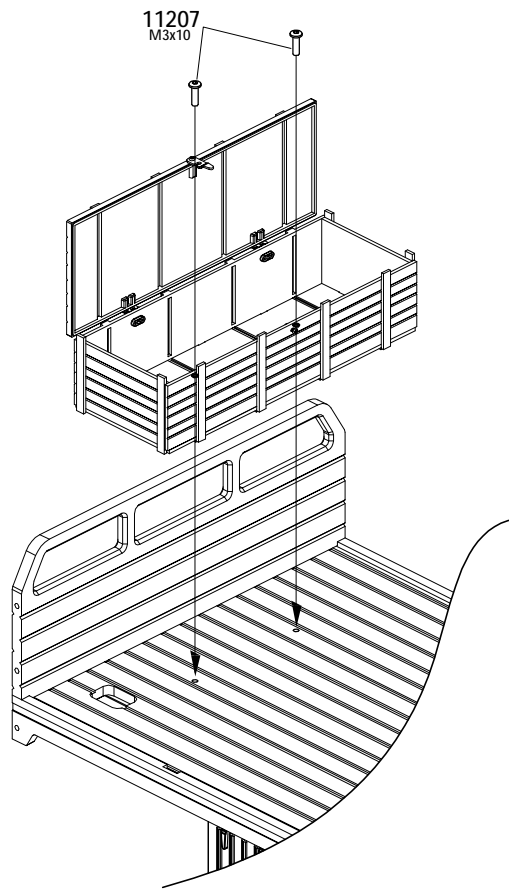
MC8B/C



11106 
M3x8 X4

11107 
M3x10 X4

85

MC8B/C

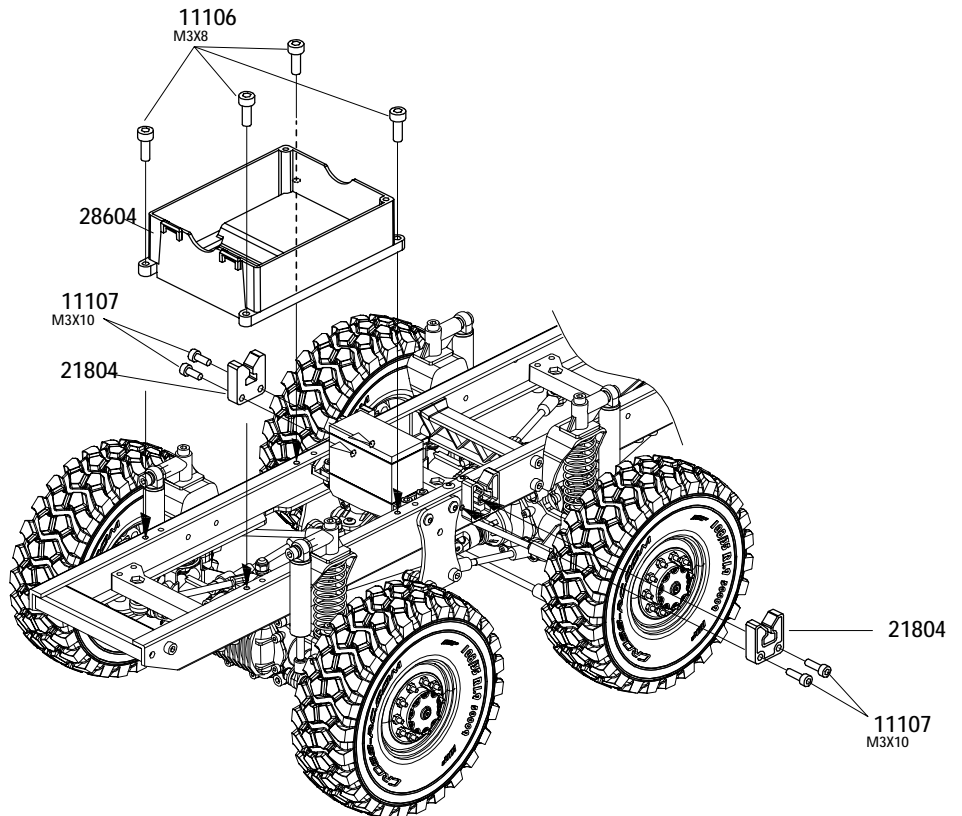

86

MC8B/C

11102 
M2x6 X4

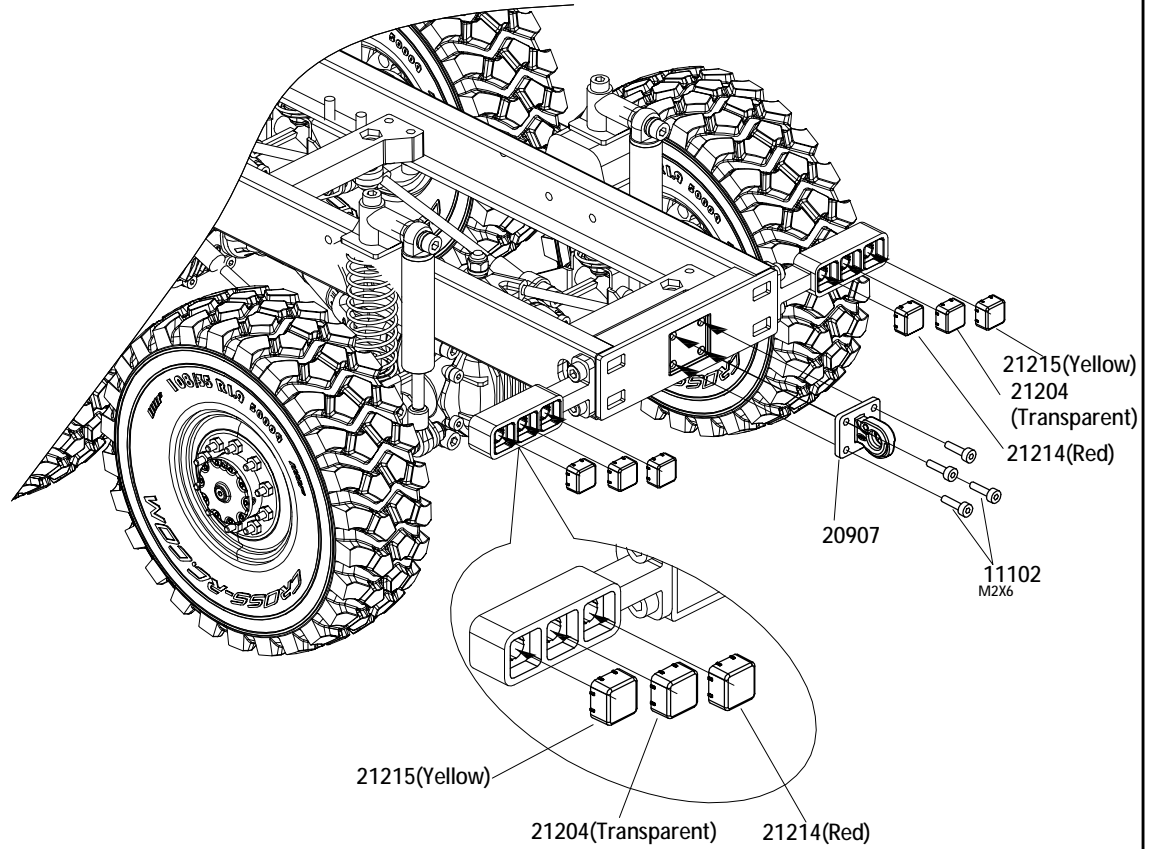

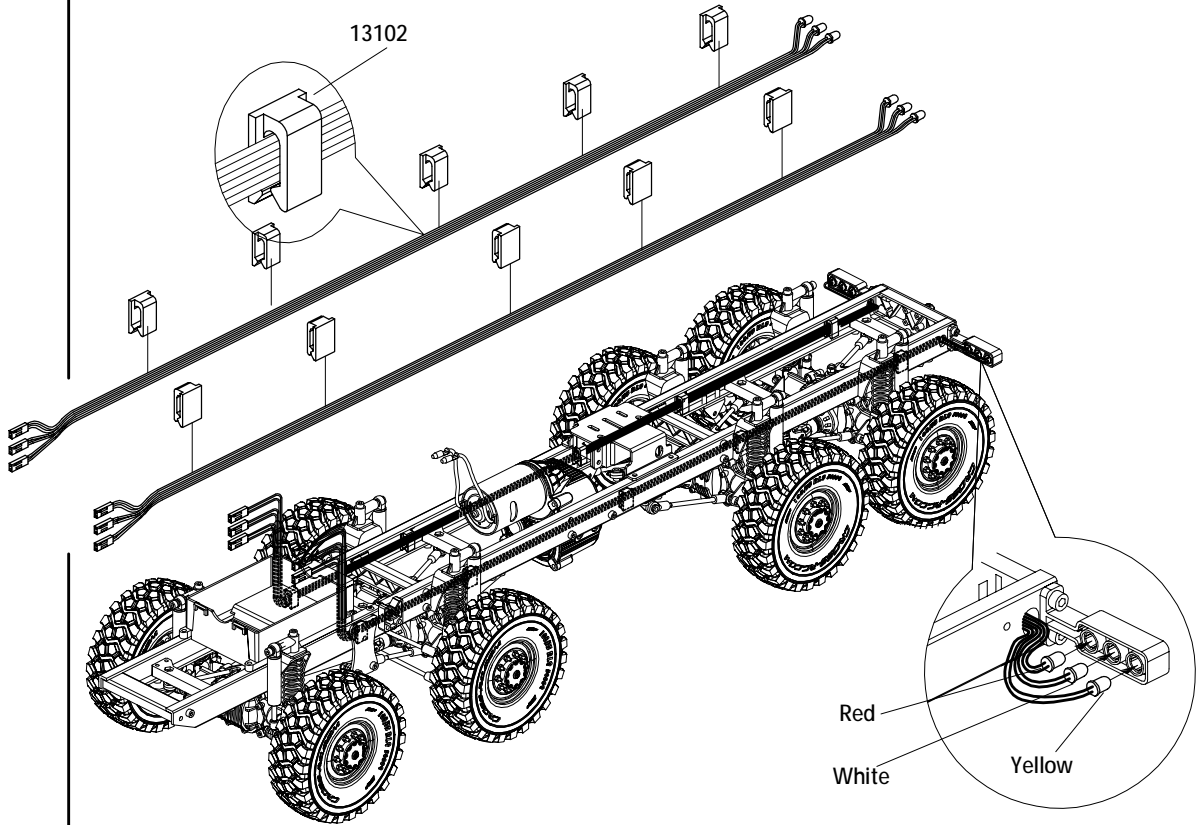

87

MC8B/C



88

MC8B/C

- 11108  M3x12 X4
- 14103  $\phi 3.2 \times \phi 9 \times 1$ X4

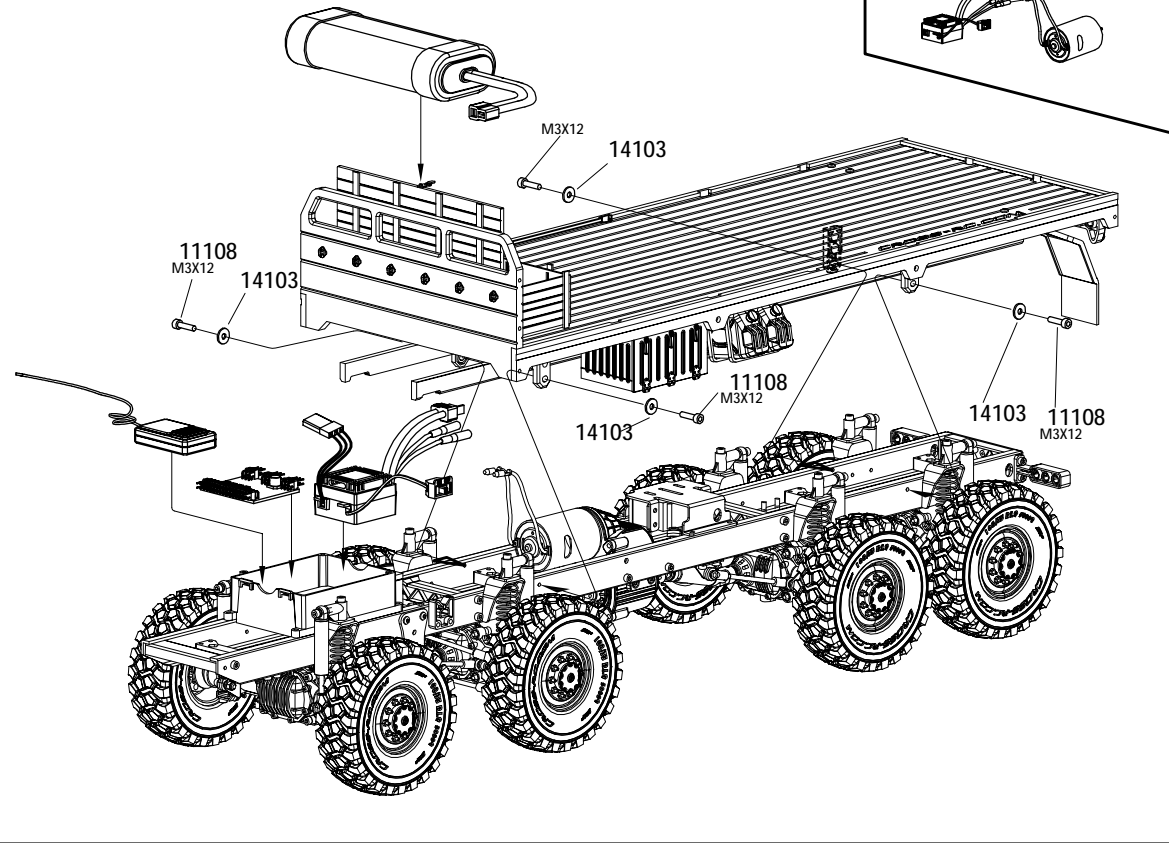
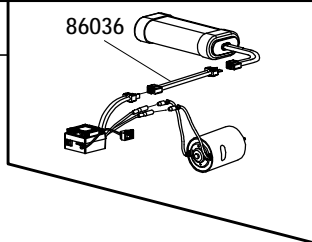



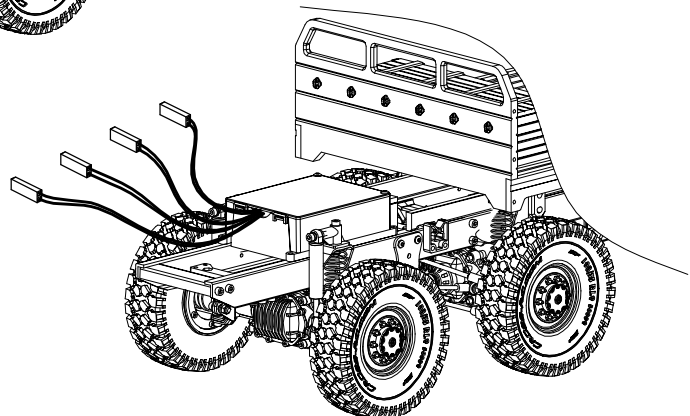
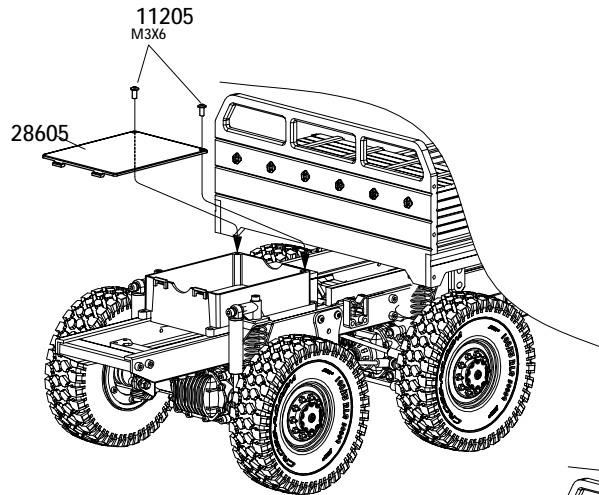

89

MC8B/C

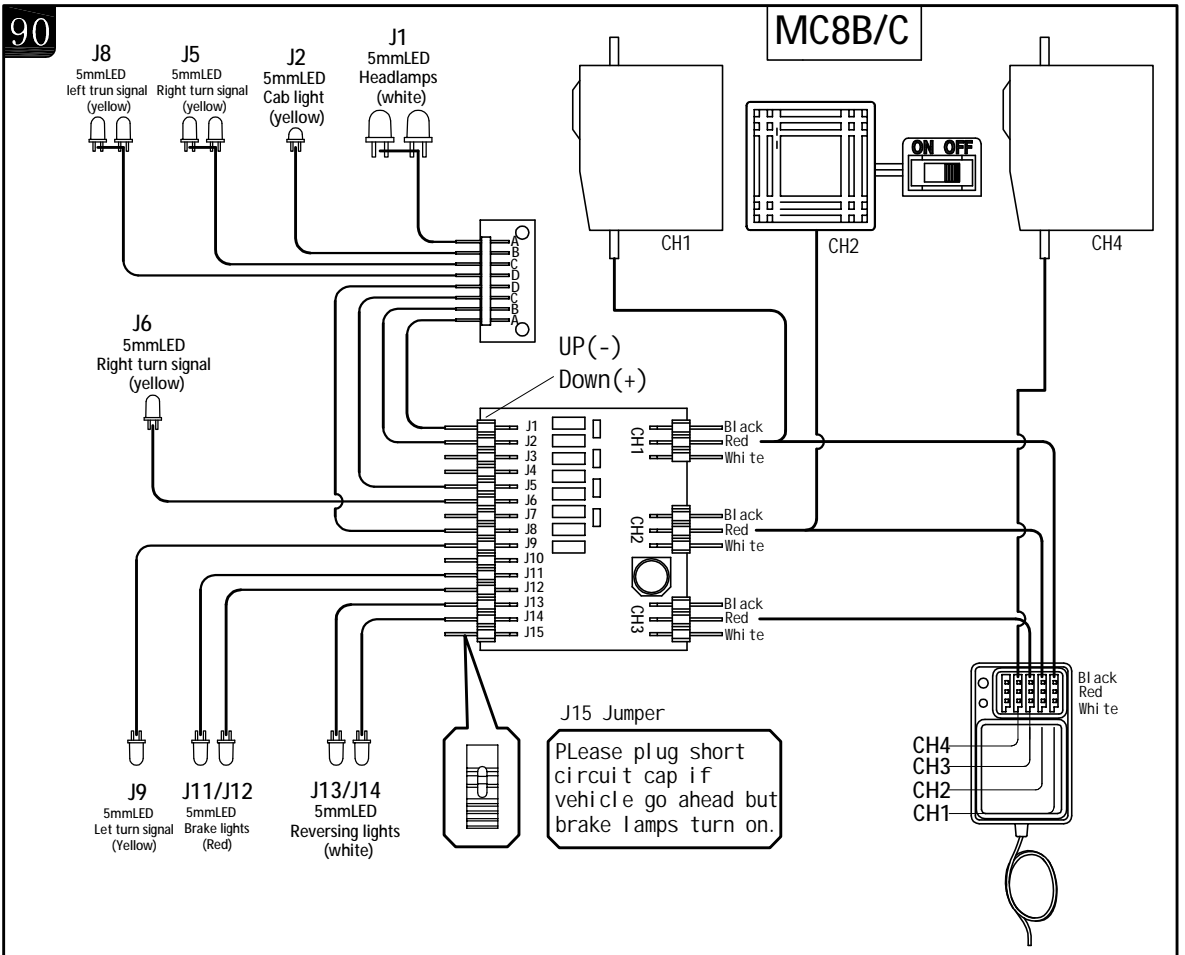
- 11205  M3x6 X2





- 11109  M3x14 X2
- 14103   $\phi 3.2 \times \phi 9 \times 1$ X2

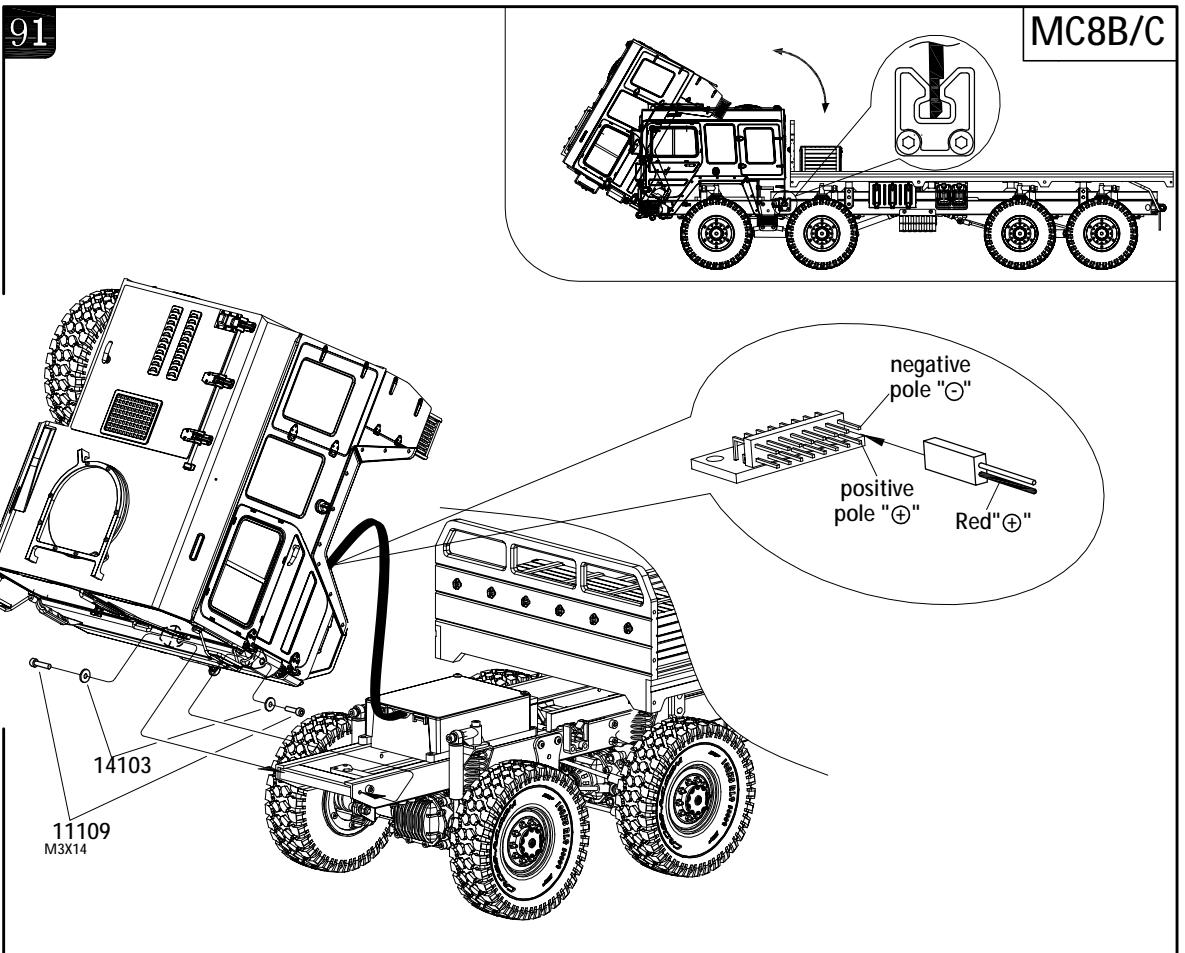

92

Flat bed

MC8B/C

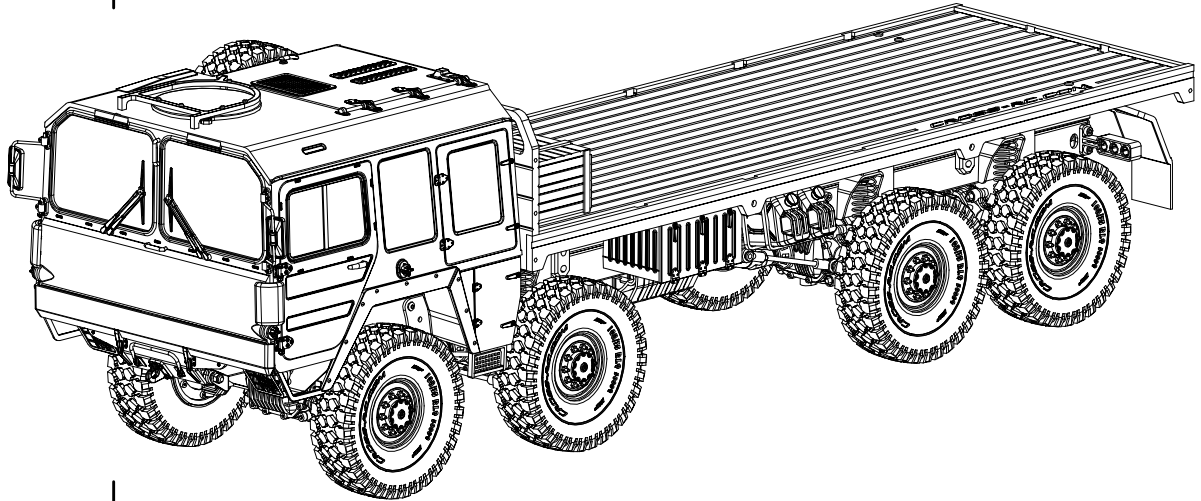

11216



M2.5x6 X16

93

MC8B/C

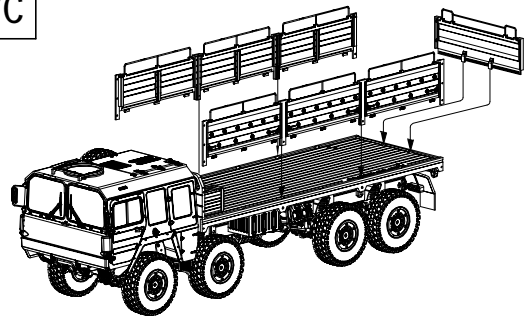

11216
M2.5x6



M2.5x6

11216
M2.5x6



M2.5x6

11216
M2.5x6



M2.5x6

11216
M2.5x6



M2.5x6

11216
M2.5x6



M2.5x6

Cargo bed

