

CAUTIONS



To prevent serious personal injury and/or property damage, operate all remotely controlled models in a responsible manner as outlined herein.

◆ **Safety Precautions**

- 1.1 Choose a right place to operate your RC model.
- 1.2 Do not operate your RC model on the street or highway. It can cause a serious damage or a serious accident.
- 1.3 Never operate your RC model near people or animals.
- 1.4 Do not operate RC model in public places like hospital and residential areas.
- 1.5 Never operate RC model indoors. There is a higher possibility of fire or damage.
- 1.6 Keep the parts out of reach of children, small parts can cause choking and vinyl bags can suffocate.
- 1.7 Do not use with children younger than 14 years.

◆ **Inspect your RC model before operation**

- 2.1 Make sure that all screws and nuts are properly tightened. It is also a good idea to use removable thread lock wherever metal screws go into metal, especially for engine mounts and the engine pilot shaft.
- 2.2 Always use fresh batteries for your transmitter and for your receiver to avoid losing control of the model.
- 2.3 Always test the brakes and throttle before starting your engine to avoid losing control of the model.
- 2.4 Always turn on the transmitter first, and then turn on the receiver.

◆ **After operation of your RC model**

- 3.1 Turn off receiver first, then turn off transmitter, this will prevent runaways.
- 3.2 Be careful when handling batteries, they will be hot after running.
- 3.3 Replace any batteries that have been dented or have frayed wires, short circuits can cause fire.

TOOLS

(Not included)

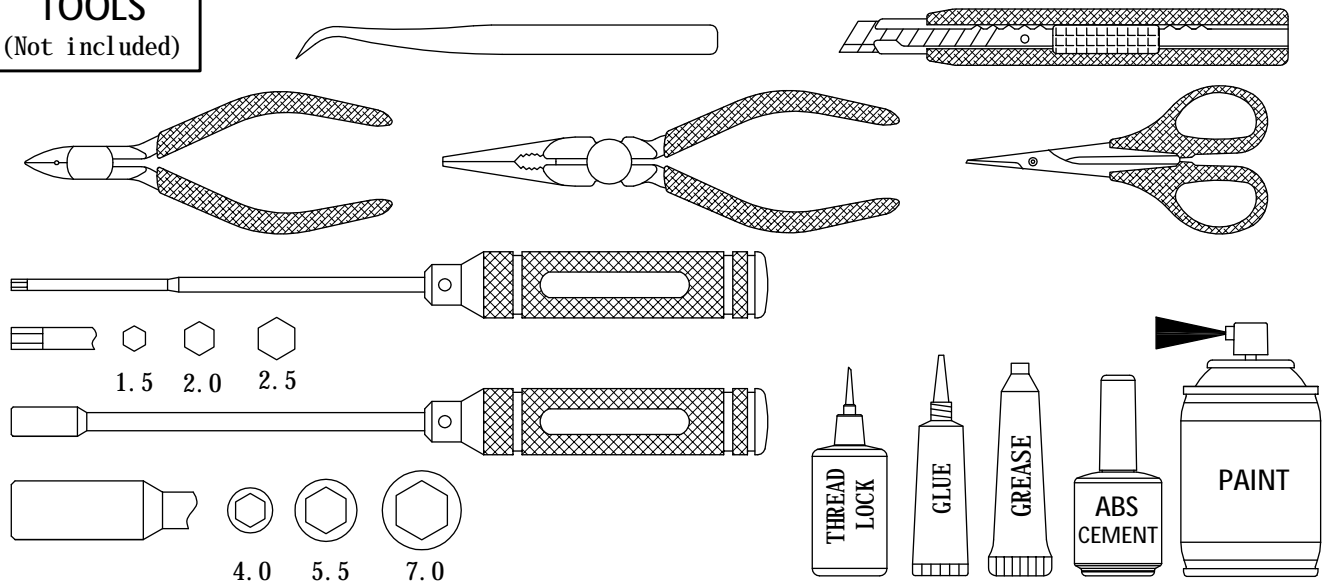

Electronic equipment

(Not included)

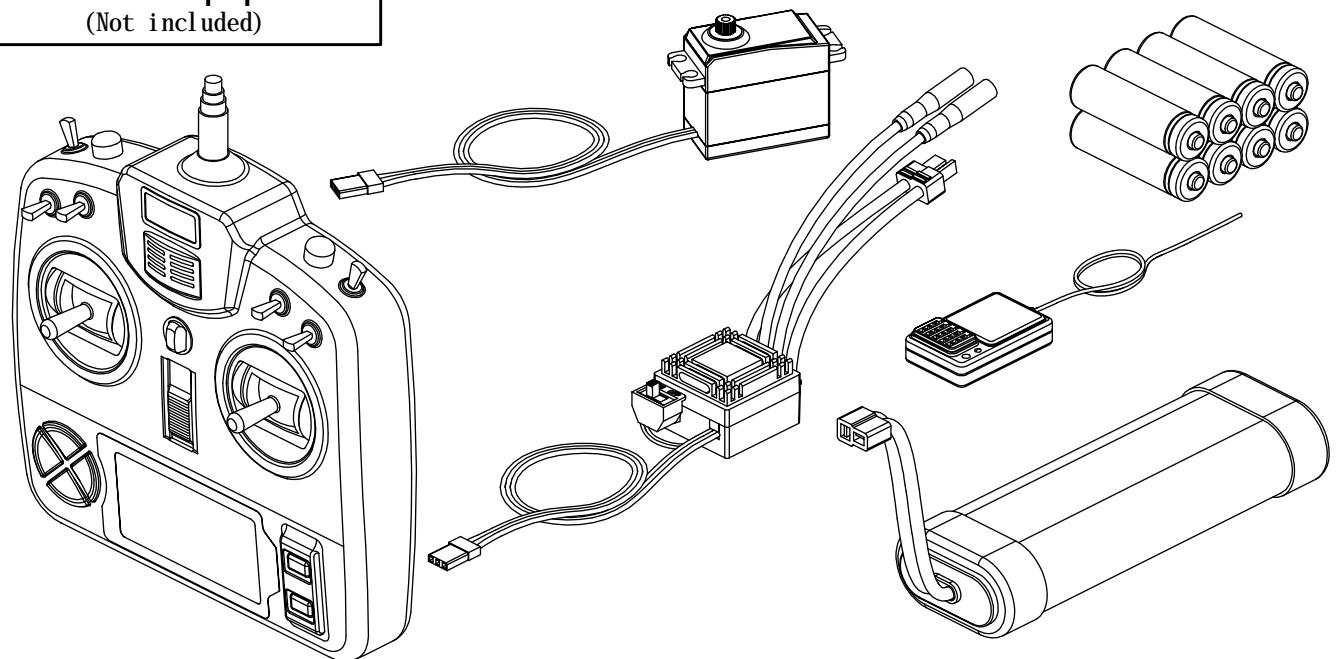

Lighting System

MC6B/C

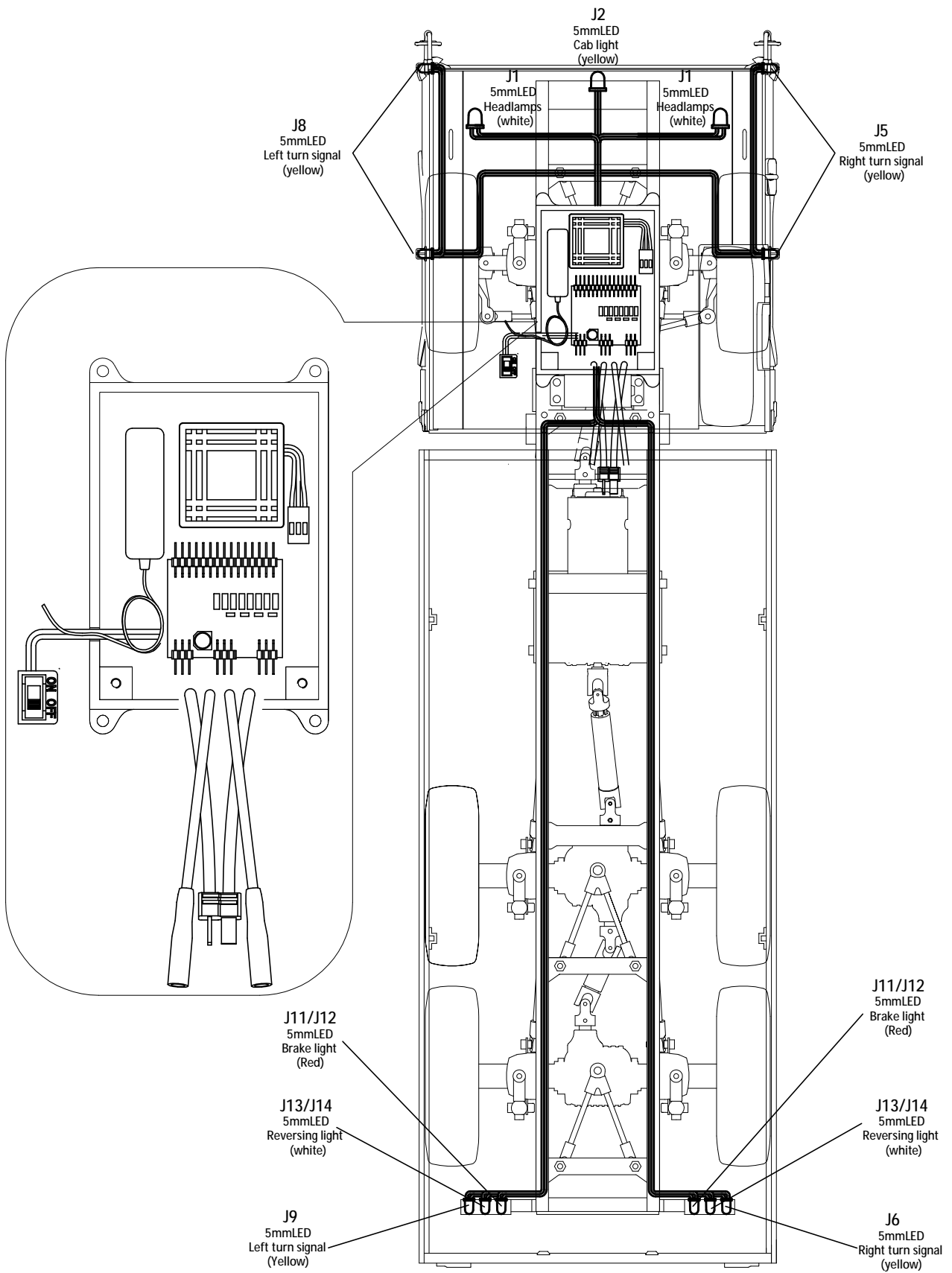

PLANK

MC6B/C

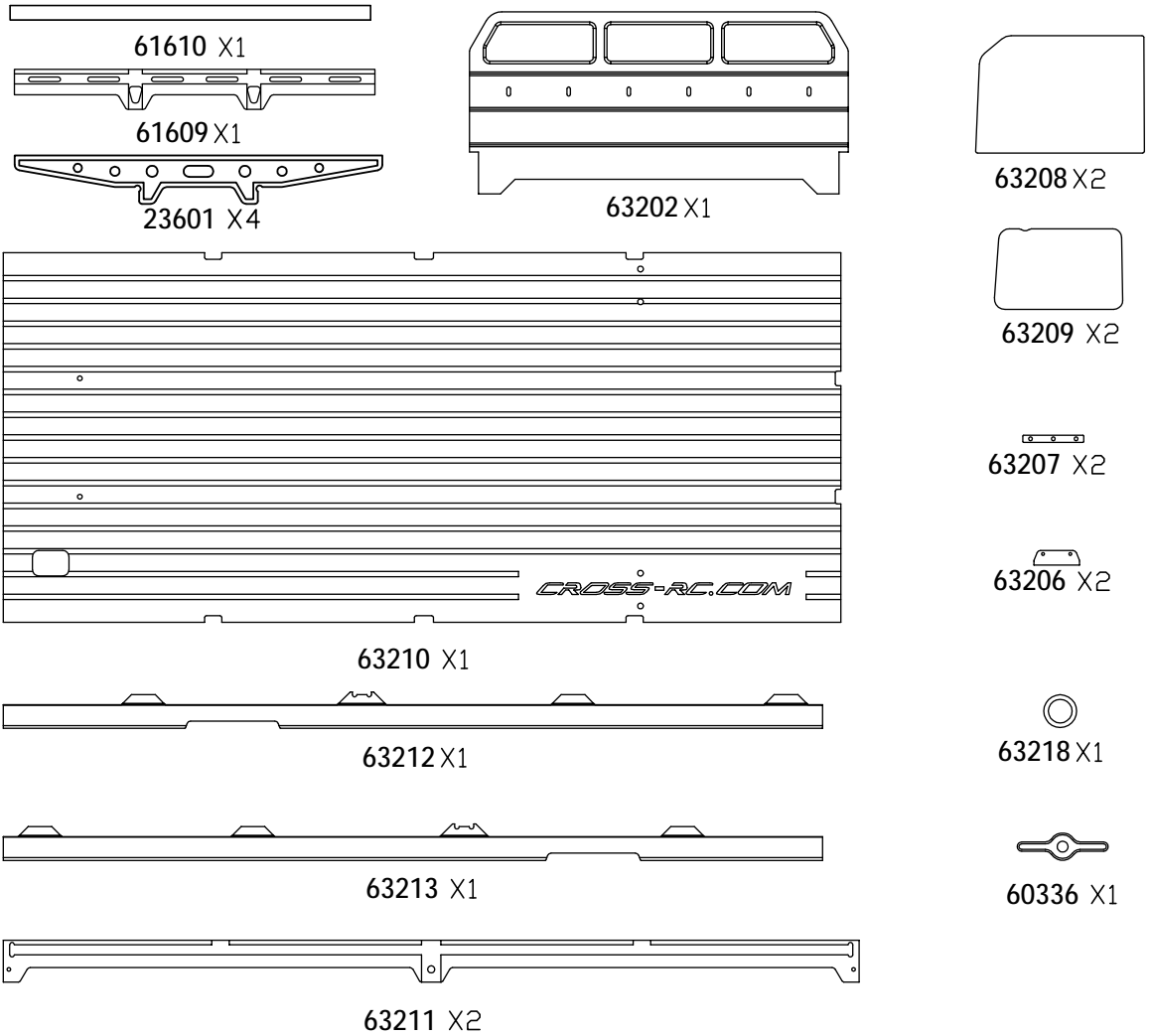

Frame

MC6B/C

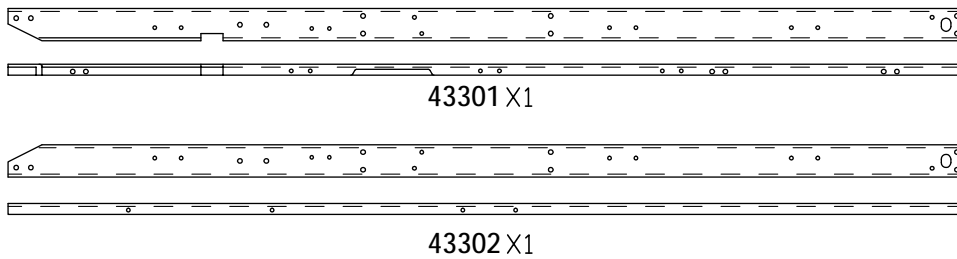

WHEELS AND TIRES

MC6B/C

11102  M2x6 X12

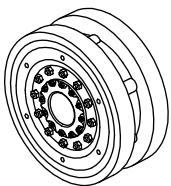

20001 X1

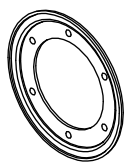

71000 X2

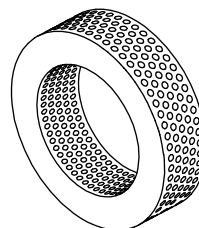

42302 X7



50009 X7

MC6B/C

12102 M2 X60 11118 M2x16 X4 11103 M2x8 X60

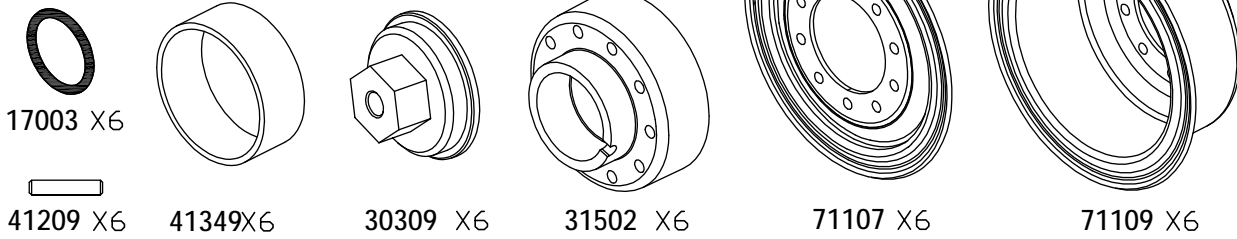

TRANSMISSION GEAR BOX

MC6B/C

11303 M3x8 X4

11401 M3x4 X1

11102 M2x6 X2

11106 M3x8 X2

11219 M3x4 X3

11207 M3x10 X4

14102 $\phi 3x\phi 7x0.5$ X2

13003 $\phi 2.5x\phi 6x0.4$ X2

13002 $\phi 3.8x\phi 9.2x0.6$ X10

15003 $\phi 5x\phi 10x4$ X12

72003 $\phi 5x\phi 8x0.5$ X2

72007 $\phi 5x\phi 8x0.3$ X2

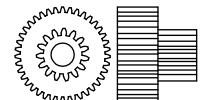
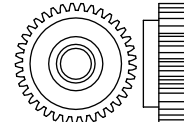
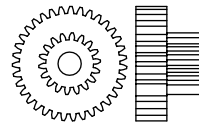
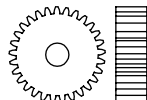
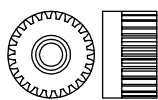
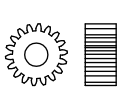
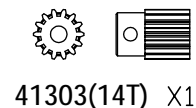
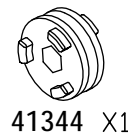
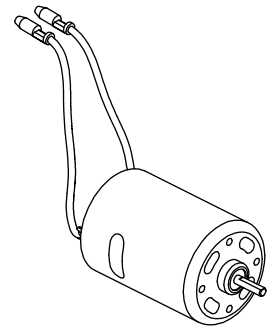
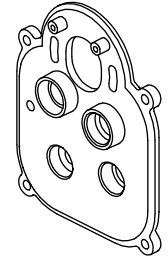
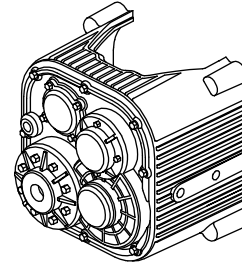
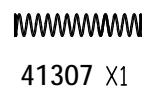
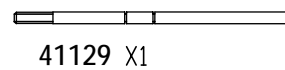
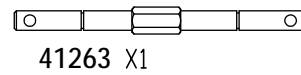
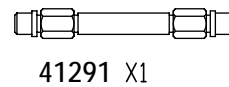
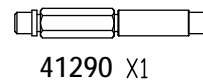
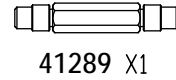
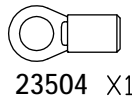
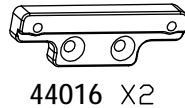

11209 M3x14 X1

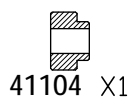

11211 M3x18 X1

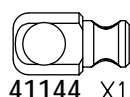

12203 M3 X2

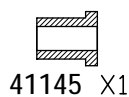

12303 M3 X1

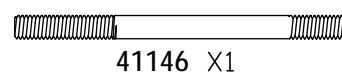



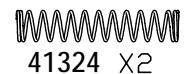

23502 X1

41336 X1



AXLES

- 15003  $\phi 5 \times \phi 10 \times 4$ X16
- 15004  $\phi 10 \times \phi 15 \times 4$ X8
- 13004  $\phi 2 \times \phi 5.5 \times 0.4$ X4
- 13002  $\phi 4 \times \phi 9 \times 0.6$ X10

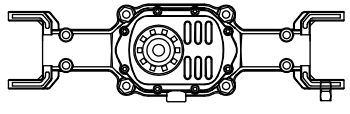

20107 X1

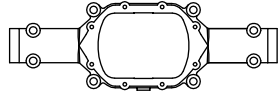

20101 X1



20106 X1

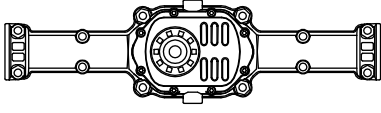

20103 X2

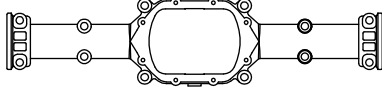

20104 X2

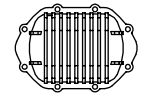

20105 X2

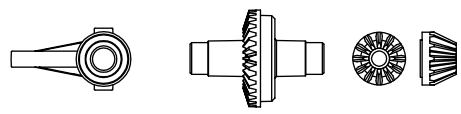

20102 X2 31701 X3 31702 X4

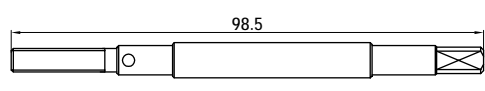

41232 X4

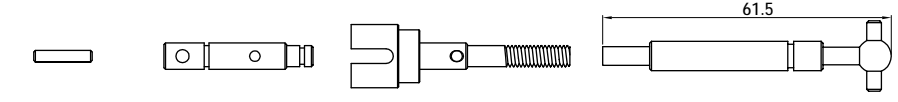

41209 X4 41210 X4 41230 X2 41203 X2



41205 X4





MC6B

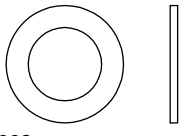



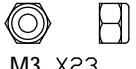

72007 $\phi 5 \times \phi 8 \times 0.3 \times 4$
72003 $\phi 5 \times \phi 8 \times 0.5 \times 4$



72008 $\phi 10 \times \phi 15 \times 0.2 \times 6$
72009 $\phi 10 \times \phi 15 \times 0.3 \times 6$
72010 $\phi 10 \times \phi 15 \times 0.5 \times 6$
optional

- 12203  M3 X23
- 11102  M2x6 X25
- 11107  M3x10 X4
- 11601  M3x16 X3
- 11108  M3x12 X20

AXLES

- 15003  $\phi 5 \times \phi 10 \times 4$ X16
- 15004  $\phi 10 \times \phi 15 \times 4$ X8
- 13004  $\phi 2 \times \phi 5.5 \times 0.4$ X4
- 13002  $\phi 4 \times \phi 9 \times 0.6$ X10

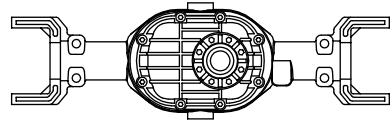

30601 X1

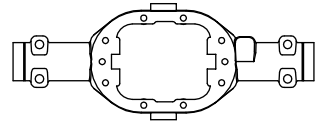

30602 X1

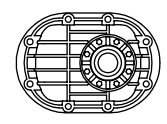

30603 X1

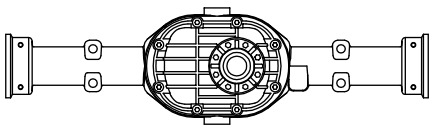

30701 X2

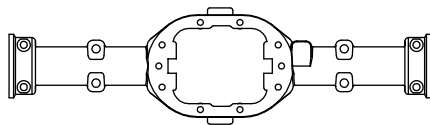

30702 X2

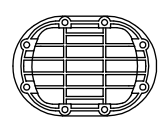

30703 X2

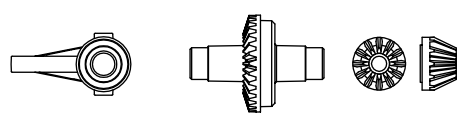

30704 X2 331701 X3 31702 X4

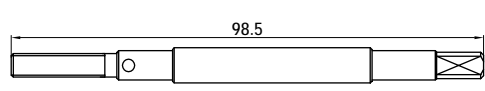

41232 X4

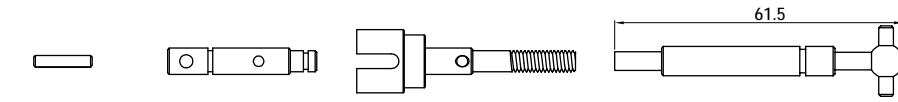

41209 X4 41210 X4 41230 X2 41203 X2

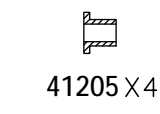

41205 X4





MC6C

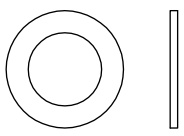

72007 $\phi 5 \times \phi 8 \times 0.3 \times 4$
72003 $\phi 5 \times \phi 8 \times 0.5 \times 4$

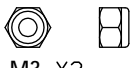

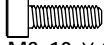
72008 $\phi 10 \times \phi 15 \times 0.2 \times 6$
72009 $\phi 10 \times \phi 15 \times 0.3 \times 6$
72010 $\phi 10 \times \phi 15 \times 0.5 \times 6$
optional

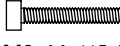
- 12203  M3 X3
- 11125  M2.5x10 X8
- 11207  M3x10 X4
- 11601  M3x16 X3
- 11126  M2x14 X24

- 11405  M4x4 X3

SUSPENSION SYSTEM **MC6B**

01 02 03 04 05 06 07 08 09 10

235 X7

41336 X37

41107 X6

41108 X6

41300(Black) X4

41306(Red) X2

12203 M3 X30

17001 $\phi 8 \times \phi 6 \times 1$ X6

17002 $\phi 6 \times \phi 2.4 \times 1.8$ X12

11106 M3x8 X6

11109 M3x14 X18

11113 M3x22 X18

14103 $\phi 3.2 \times \phi 9 \times 1$ X6

12303 M3 X6

71002 X6

41307 X6

47,53

41101 X4

56,26

41100 X8

SUSPENSION SYSTEM **MC6C**

01 02 03 04 05 06 07 08 09 10

235 X7

41336 X37

41107 X6

41108 X6

41300(Black) X4

41306(Red) X2

41307 X6

30301 X6

30302 X6

17001 $\phi 8 \times \phi 6 \times 1$ X6

17002 $\phi 6 \times \phi 2.4 \times 1.8$ X12

11106 16M3x8 X12

11109 M3x14 X18

11113 M3x22 X12

14103 $\phi 3.2 \times \phi 9 \times 1$ X12

12203 M3 X30



71002 X6



47,53

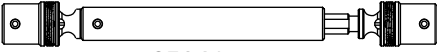
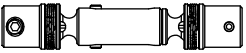

41101 X4

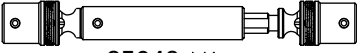

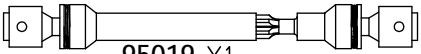
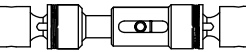

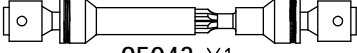

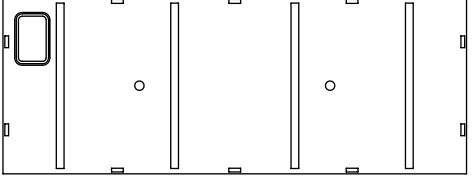
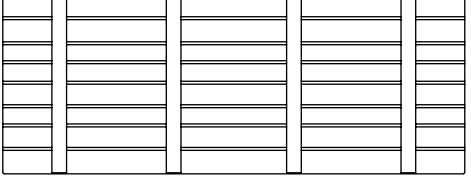
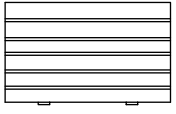
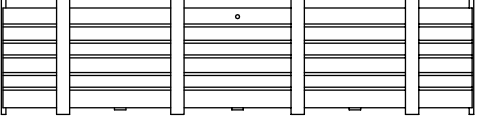
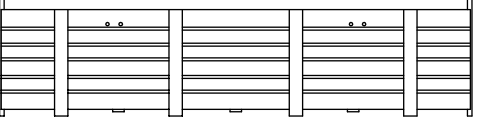

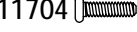
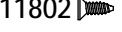

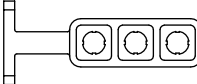

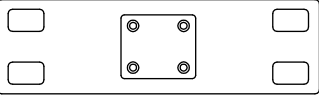
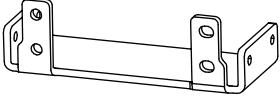

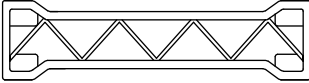

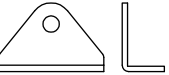
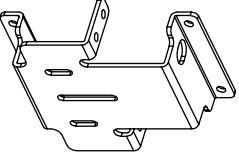
56,26

41100 X8

DRIVE SHAFTS		95041 X1		95034 X1		11409 M3x10 X6	MC6B
		95042 X1					

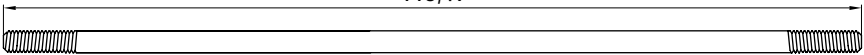
DRIVE SHAFTS		95019 X1		95022 X1		11406 M3x12 X6	MC6C
		95043 X1					

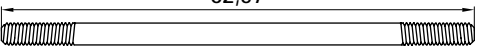
THE BATTERY BOX		28801 X1		28802 X1		28803 X2	MC6B/C	
		28804 X1		28805 X1		72019 X1		
						11704 M1.6x6 X2		11802 ST1.4x4 X8























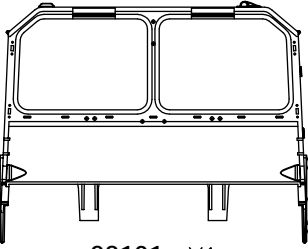
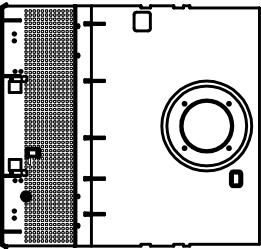

BAG(FA)		28702 X1		21906 X2		11106 M3x8 X38	MC6B/C
		20602 X1		71052 X1		11109 M3x14 X6	
		20604 X1		20606 X3		11110 M3x16 X1	
		71001 X6		71074 X1		11111 M3x18 X6	
						11114 M3x25 X1	
						11122 M3x35 X1	
						11207 M3x10 X12	
						11205 M3x6 X16	
		41102 X1				12203 M3 X19	
		41135 X1				14102 $\phi 3 \times \phi 7 \times 0.5$ X4	

BAG(FB)							MC6B/C
11102 M2x6 X2		11501 ST2.6x6 X4		11216 M2.5x6 X4		12105 M2.5 X4	
						11205 M3x6 X2	
21100 X2		21200 X2		21106 X2		21110 X2	
						71016 X1	
						71017 X1	

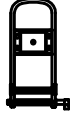
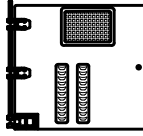
BAG(FC)							MC6B/C
11102 M2x6 X4		12001 M2x6 X6		11207 M3x10 X4		12203 M3 X4	
						12102 M2 X6	
71104 X1		50025 X2		71106 X4		71105 X1	

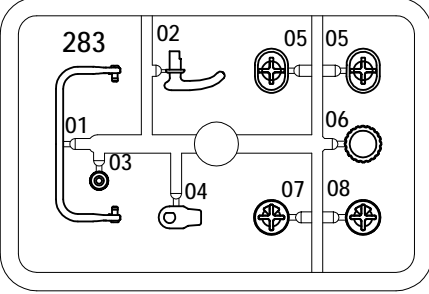
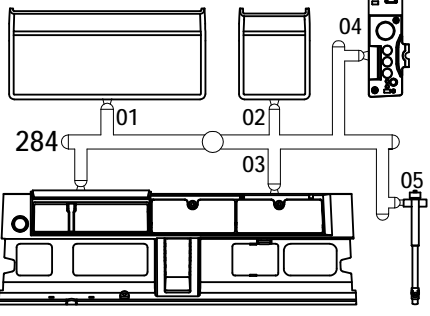
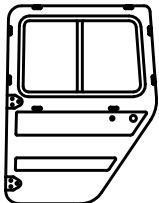
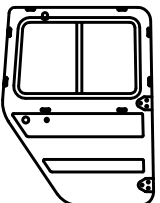
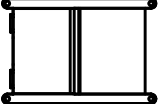
BAG(FD)							MC6B/C
11801 ST1.4x6 X16		11802 ST1.4x4 X20		11707 M1.6X10X4		12106 M1.6 X4	
27105 X2		27107 X2		24704 X4		71089 X2	
						73036 X2	
						72023 X4	
						72024 X4	

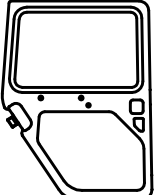
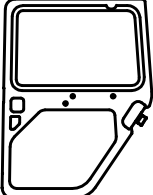
BAG(FE)							MC6B/C
						MAN 60338 X1	
13102 X13		21204 X2 (transparent) 21214 X2 (Red) 21215 X2 (Yellow)		21804 X2		30104 X1	
						30106 X1	
						41117 X5	
71102 X4		71103 X1					

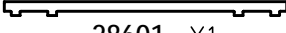
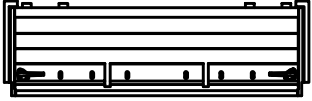
<p>BAG(FF)</p>		<p>MC6B/C</p>		
<p>11102  M2x6 X4</p>	<p>11109  M3x14 X2</p>	<p>11218  M2.5x4 X4</p>	<p>12002  M2x10 X4</p>	<p>14103  $\phi 3.2 \times \phi 9 \times 1$ X6</p>
<p>11106  M3x8 X4</p>	<p>11108  M3x12 X4</p>	<p>11216  M2.5x6 X15</p>	<p>11801  ST1.4x6 X1</p>	
<p>11107  M3x10 X4</p>	<p>11205  M3x6 X6</p>	<p>11207  M3x10 X2</p>	<p>12204  M X6</p>	
<p>11701  M3x45 X1</p>		<p>12102  M2 X4</p>	<p>12203  M3 X1</p>	
<p>No.281</p>	<p>MC6B/C</p>	<p>No.282</p>	<p>MC6B/C</p>	
<p> 28101 X1</p>		<p> 28205 X1</p>	<p> 28202 X1</p>	<p> 28201 X1</p>
			<p> 28204 X1</p>	<p> 28203 X1</p>
<p>No.283</p>	<p>MC6B/C</p>	<p>No.284</p>	<p>MC6B/C</p>	
<p> 283 X1</p>		<p> 284 X1</p>		
<p>No.285</p>	<p>MC6B/C</p>	<p>No.286</p>	<p>MC6B/C</p>	
<p> 28501 X1</p>	<p> 28502 X1</p>	<p> 28604 X1</p>	<p> 28603 X2</p>	<p> 28602 X2</p>
<p> 28503 X1</p>	<p> 28504 X1</p>	<p> 28605 X1</p>	<p> 28601 X1</p>	<p> 28606 X1</p>

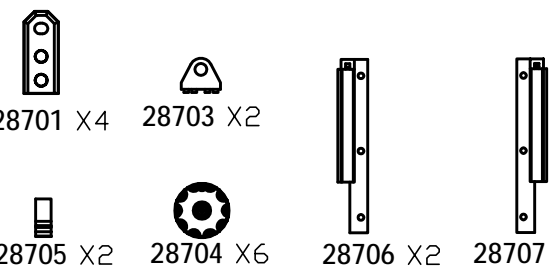
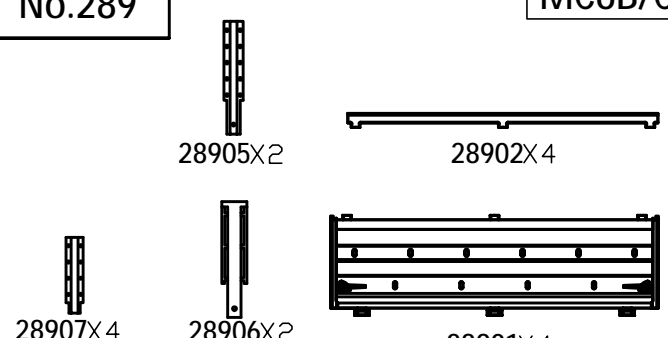
<p>No.287</p>  <p>28701 X4 28703 X2 28705 X2 28704 X6 28706 X2 28707 X2</p>	<p>No.289</p>  <p>28905X2 28902X4 28907X4 28906X2 28901X4</p>
--	--

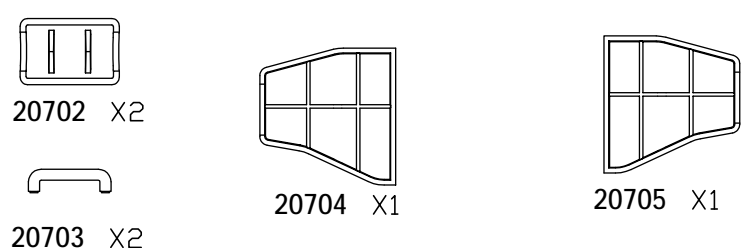
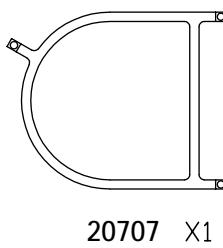
<p>No.207</p>  <p>20702 X2 20703 X2 20704 X1 20705 X1</p>	<p>MC6B/C</p>  <p>20707 X1</p>
--	--

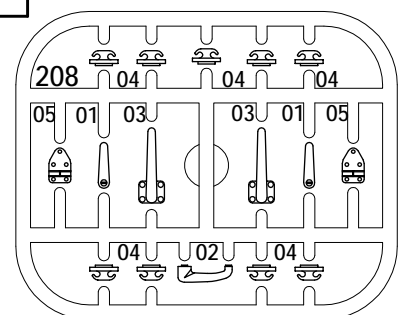
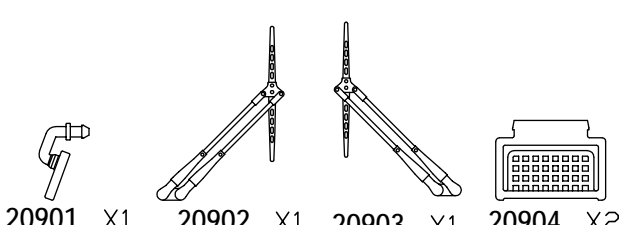
<p>No.208</p>  <p>208 X6</p>	<p>No.209</p>  <p>20901 X1 20902 X1 20903 X1 20904 X2</p>
--	---

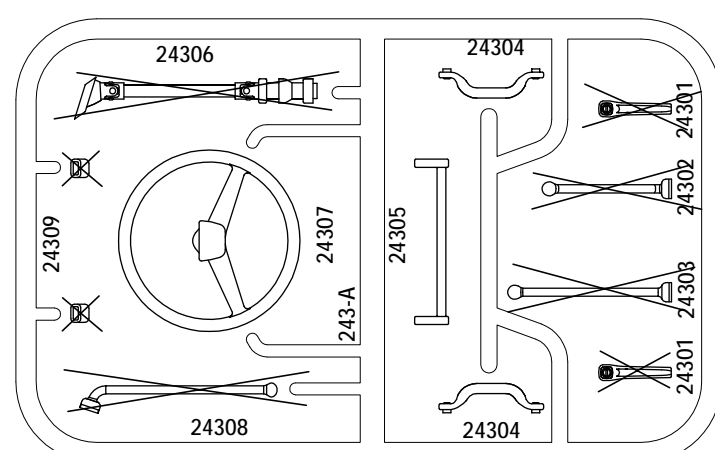
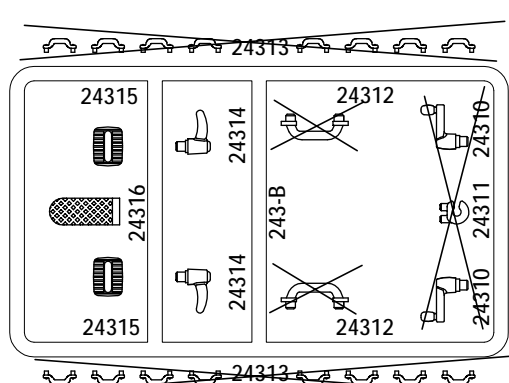
<p>No.243</p>  <p>243 X1</p>	<p>MC6B/C</p> 
--	---

MC6B/C

1

12102  M2 X60

11103  M2x8 X60

11118  M2x16 X4

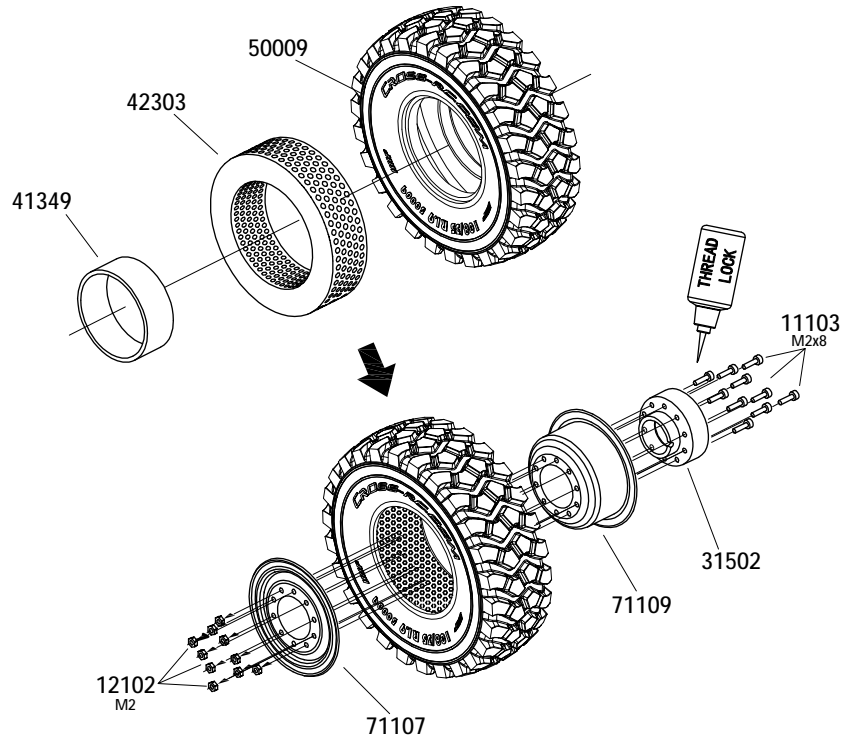



X6

2

MC6B/C

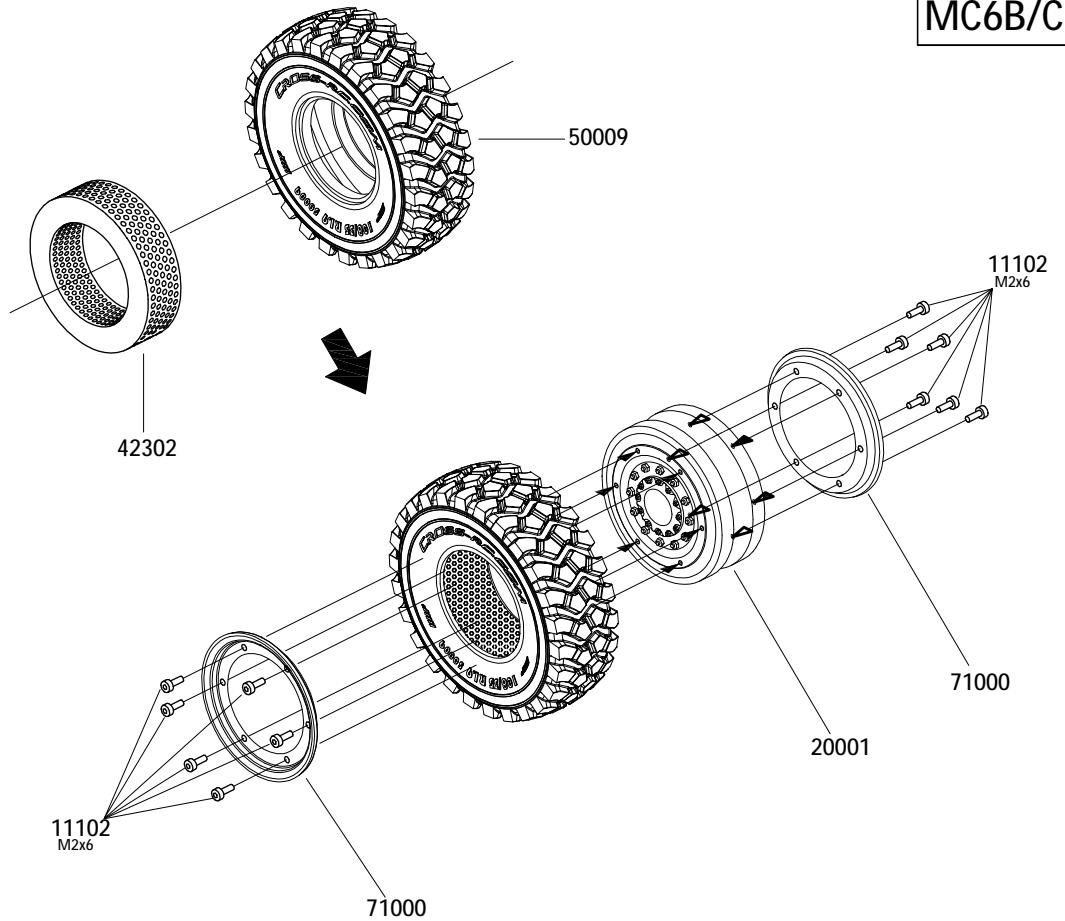
11102  M2x6 X12



13002 
 $\phi 3.8 \times \phi 9.2 \times 0.6 \times 10$

13003 
 $\phi 2.5 \times \phi 6 \times 0.4 \times 2$

72007 
 $\phi 5 \times \phi 8 \times 0.3 \times 2$

15003 
 $\phi 5 \times \phi 10 \times 4 \times 4$

72003 
 $\phi 5 \times \phi 8 \times 0.5 \times 2$

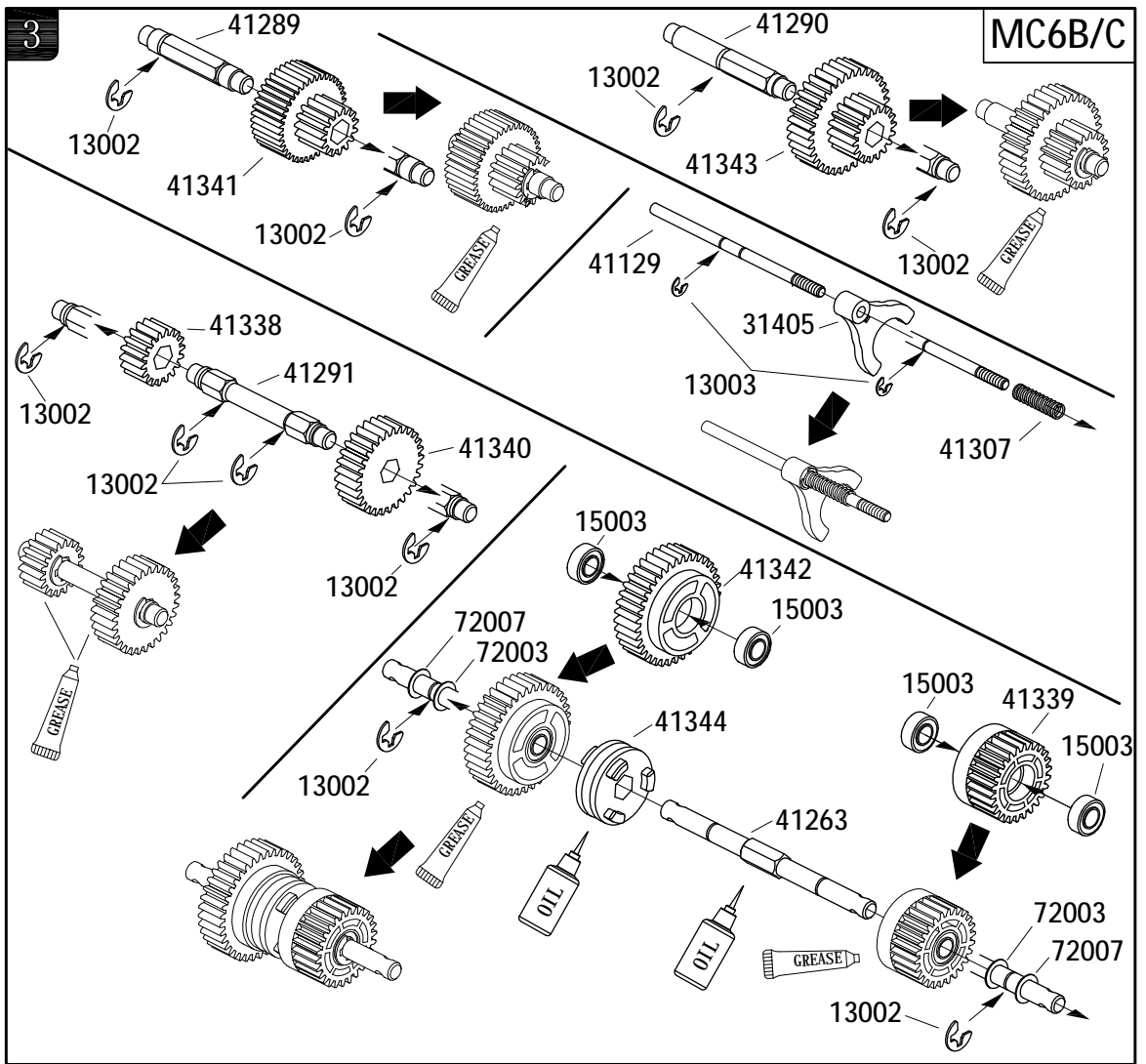

11219 
 M3x4 X3



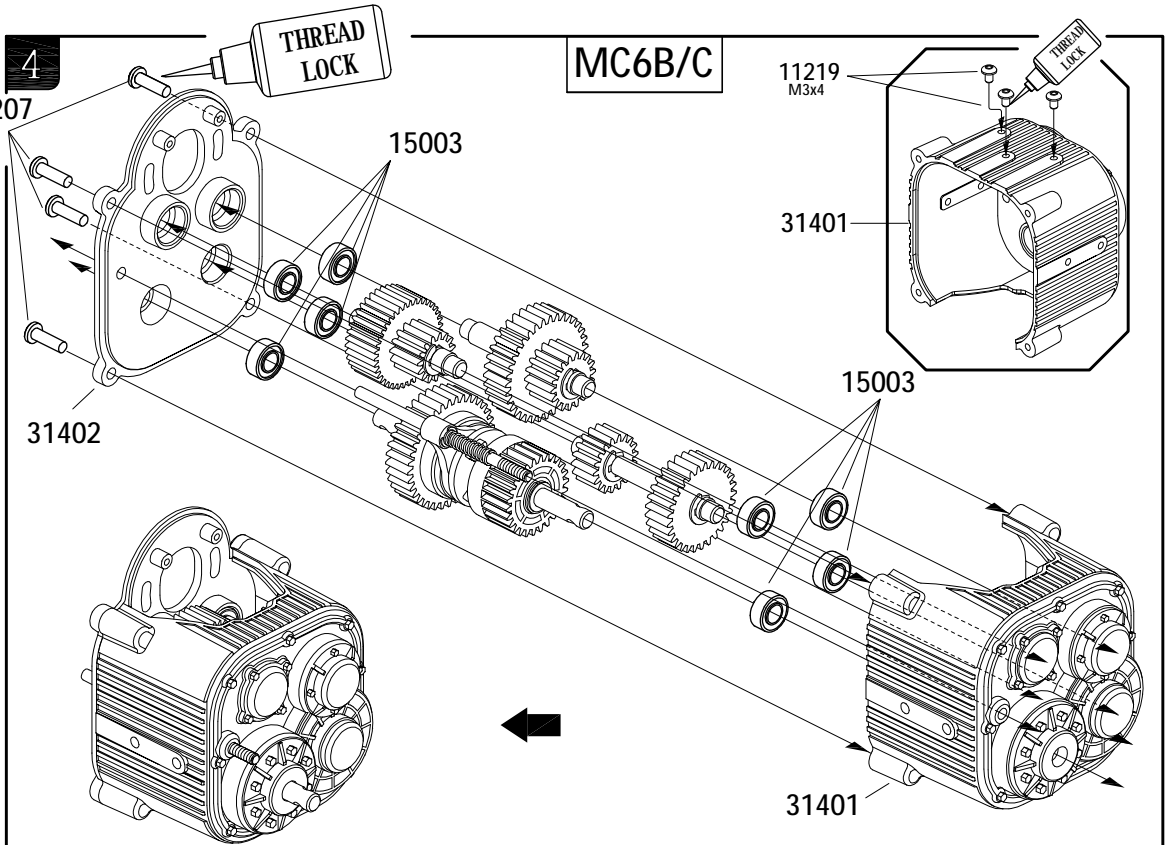

15003 
 $\phi 5 \times \phi 10 \times 4 \times 8$

11207 
 M3x10 X4



5



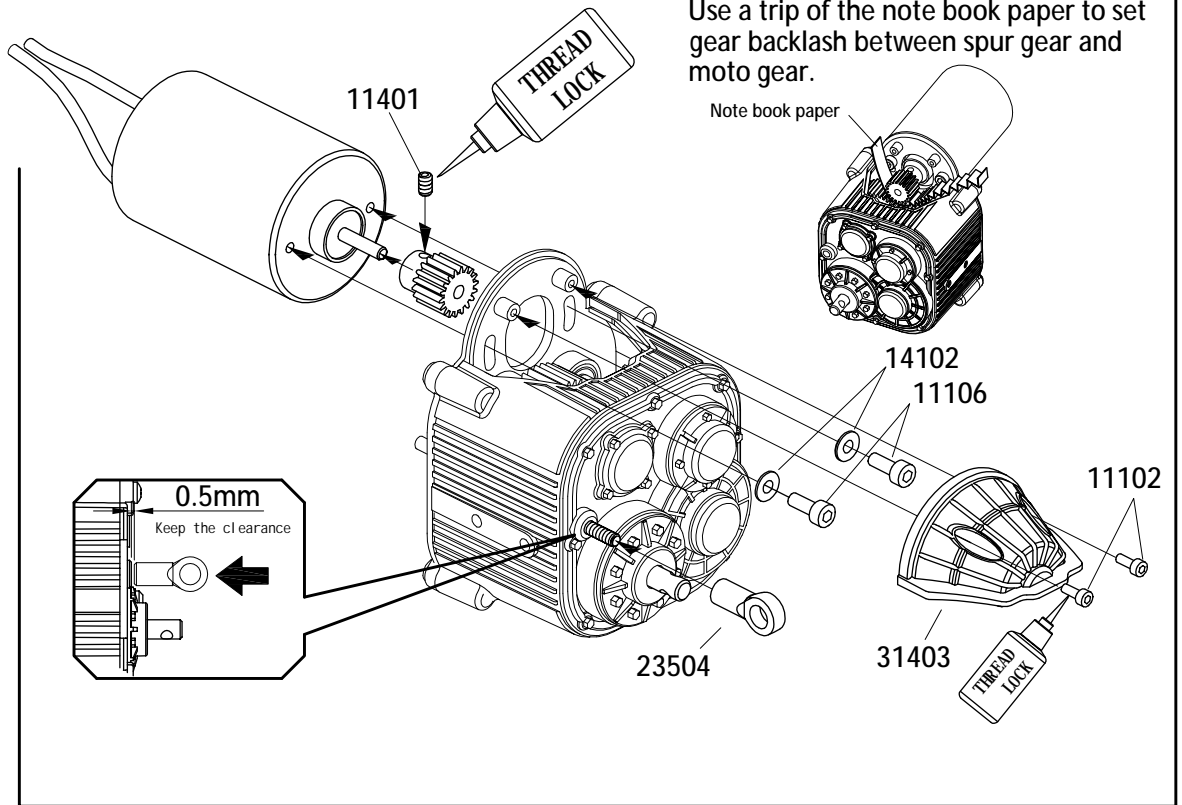

MC6B/C

- 11102  M2x6 X2
- 11106  M3x8 X2
- 11401  M3x4 X1
- 14102  $\phi 3 \times \phi 7 \times 0.5$ X2



6

MC6B/C

- 12203  M3 X2
- 12303  M3 X1
- 11209  M3x14 X1
- 11211  M3x18 X1

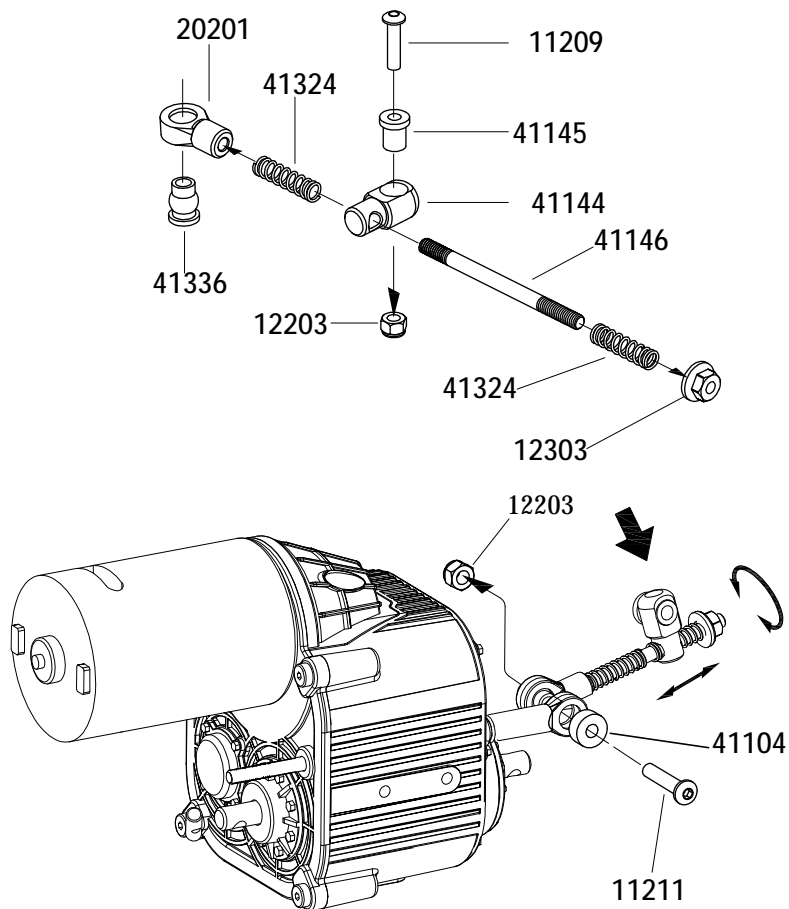

7

MC6B/C

NOTE:
Get power test after assembly finish and adjust gear meshing clearance for make sure gear box running smooth without noise, then process to following assembly go on.

1st Gear
(Low speed)

2nd Gear
(High speed)

8

MC6B/C

11303 M3x8 X4

95043 (95042)

11402 (11409)

44016

11303

95019 (95041)

95041 X1

95042 X1

11409 M4x11 X2

95043 X1

11402 M3x10 X2

95041 X1	MC8B	95019 X1	MC8C
95042 X1	11409 M4x11 X2	95043 X1	11402 M3x10 X2

MC6B/C

9

11207  M3x10 X4

11106  M3x8 X10

11107  M3x10 X4

14102  $\phi 3 \times \phi 7 \times 0.5$ X4

12203  M3 X4

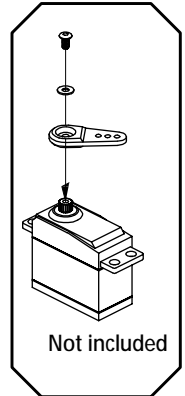
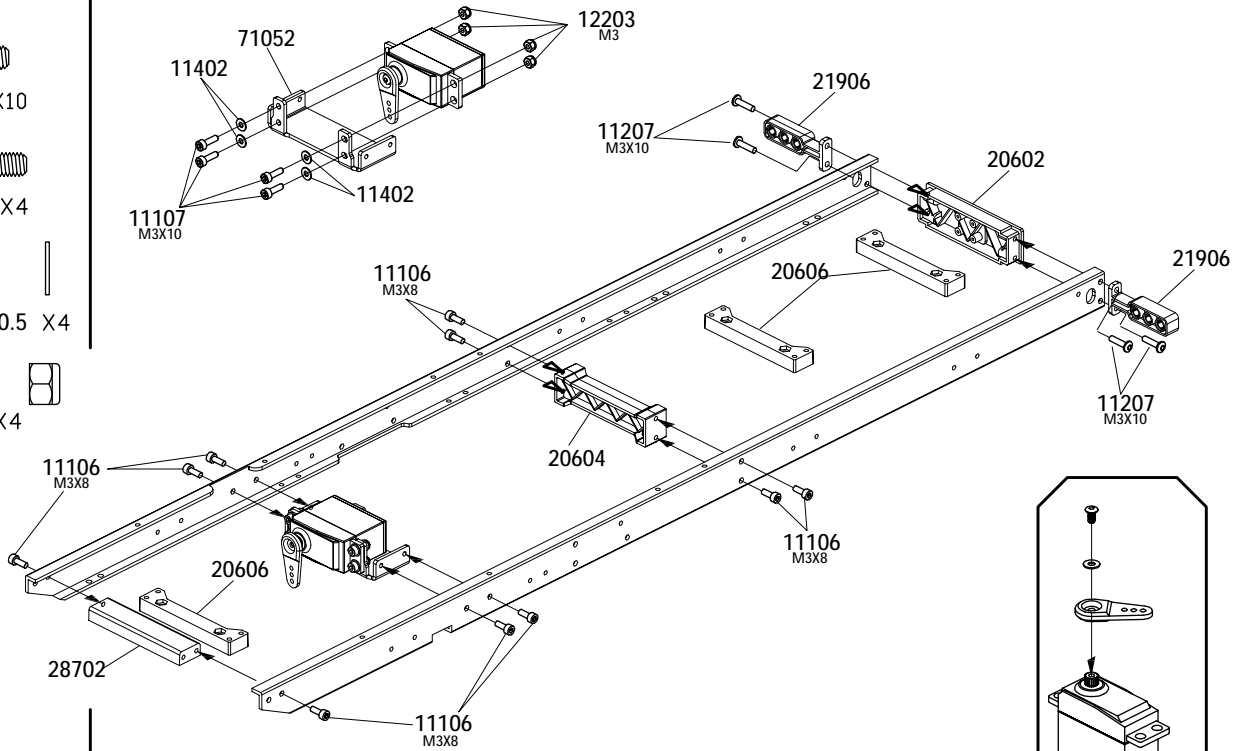

10

MC6B/C

11207  M3x10 X9



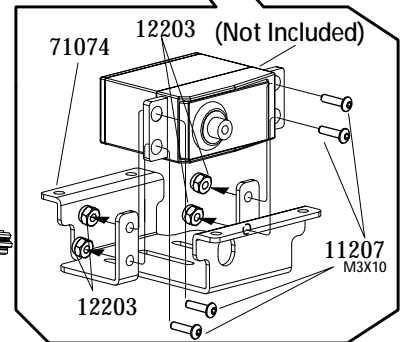
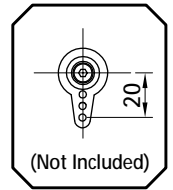
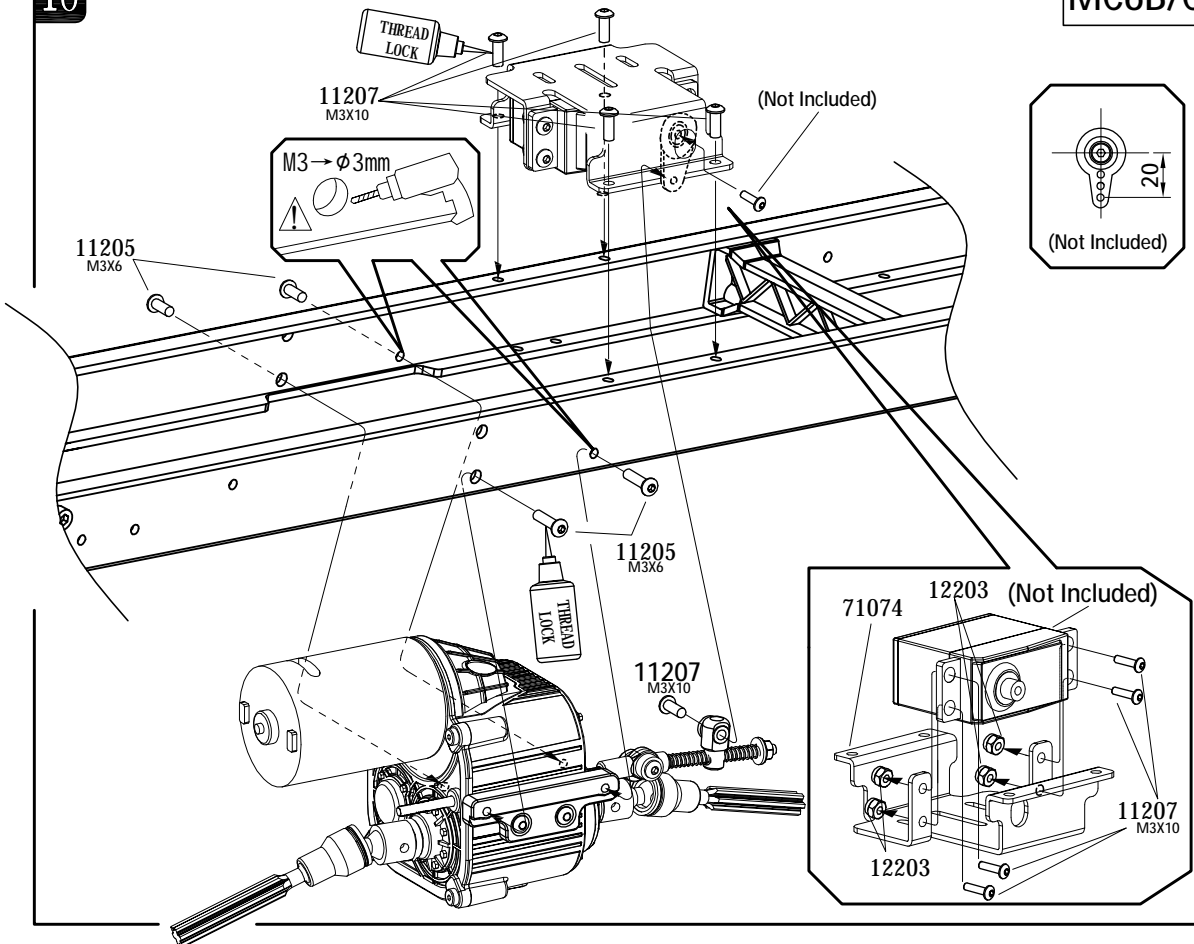

11205  M3x6 X4

12203  M3 X4



MC6B/C

11

- 11106  M3x8 X24
- 11110  M3x16 X1
- 12203   M3 X1

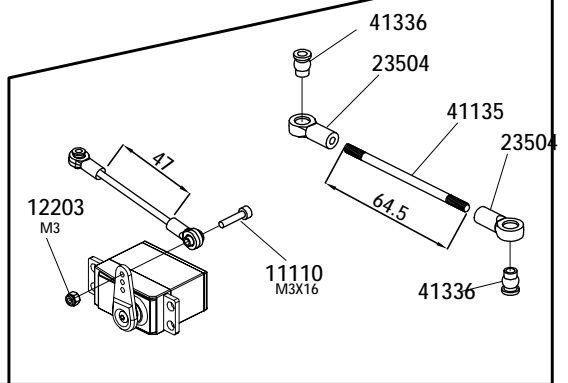
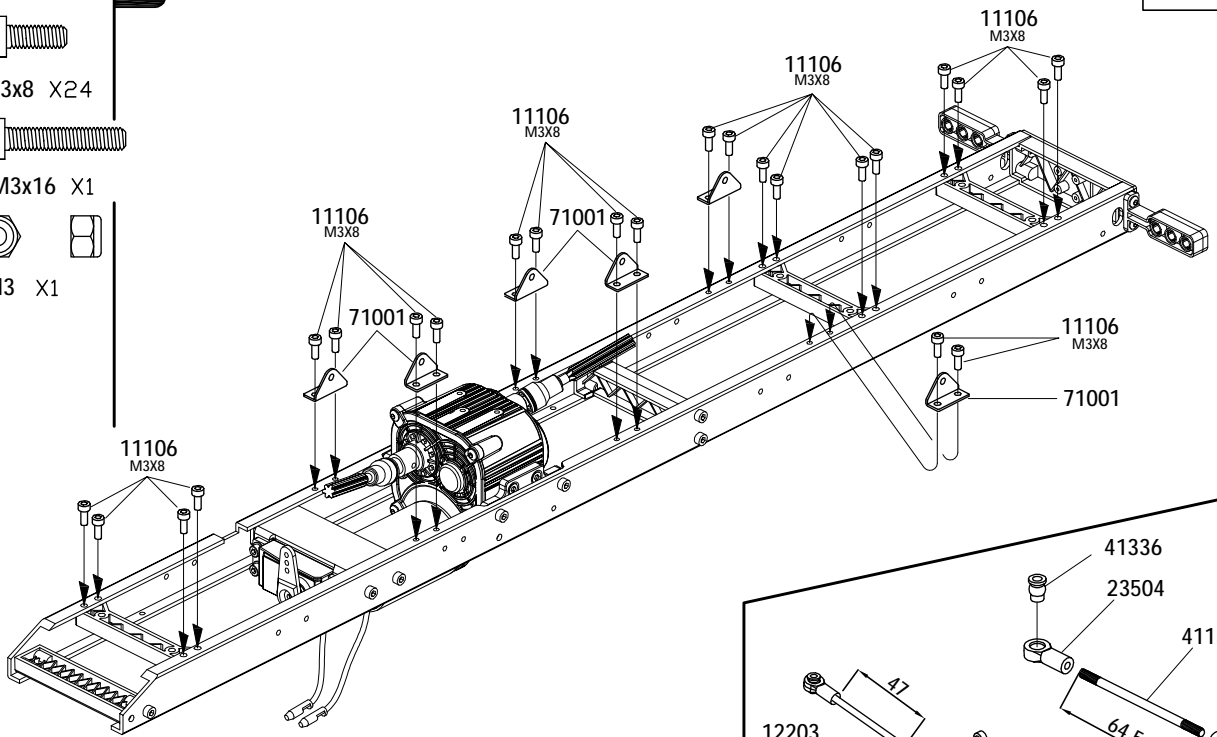

12

X4

- 13004  $\phi 2 \times \phi 5.5 \times 0.4 \times 4$

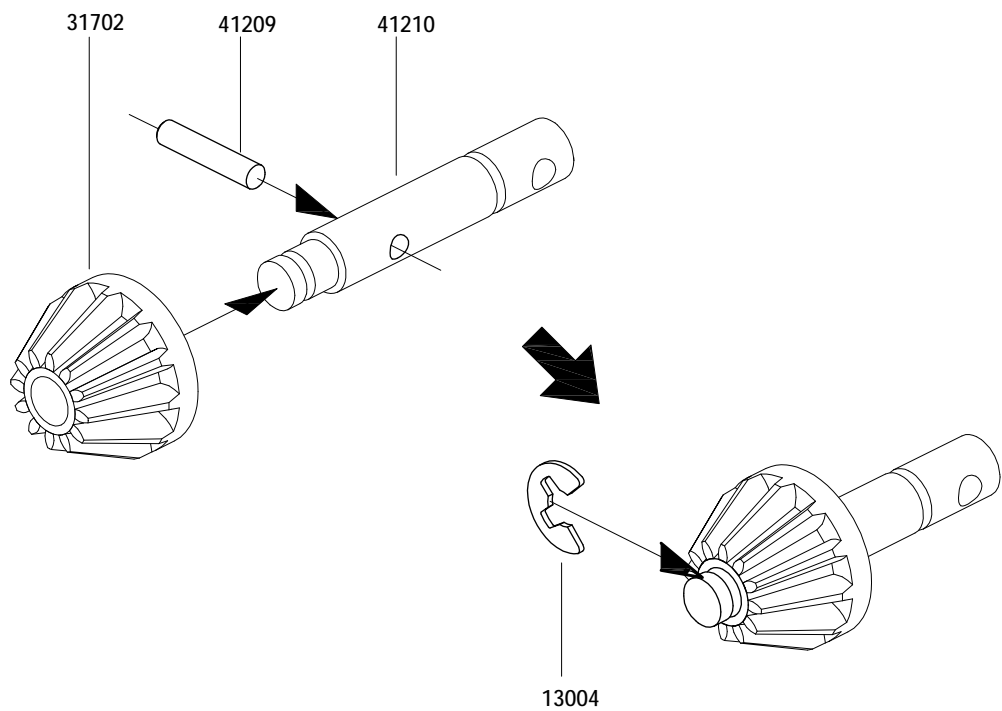

13

MC6B

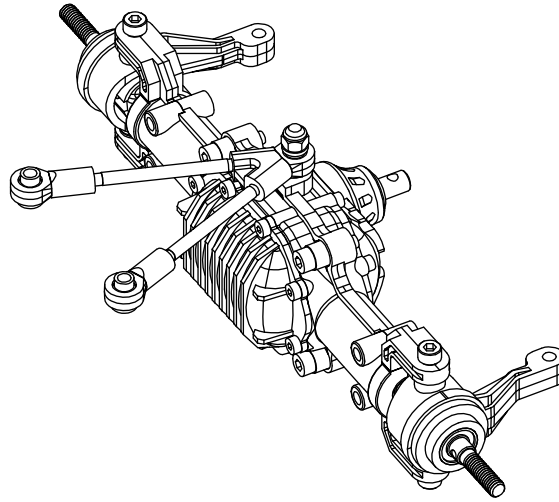

The first axle







14

The first axle

MC6B

15003  
φ5xφ10x4 X2

13002  
φ4xφ9x0.6 X1

72007  
φ5xφ8x0.3 X1

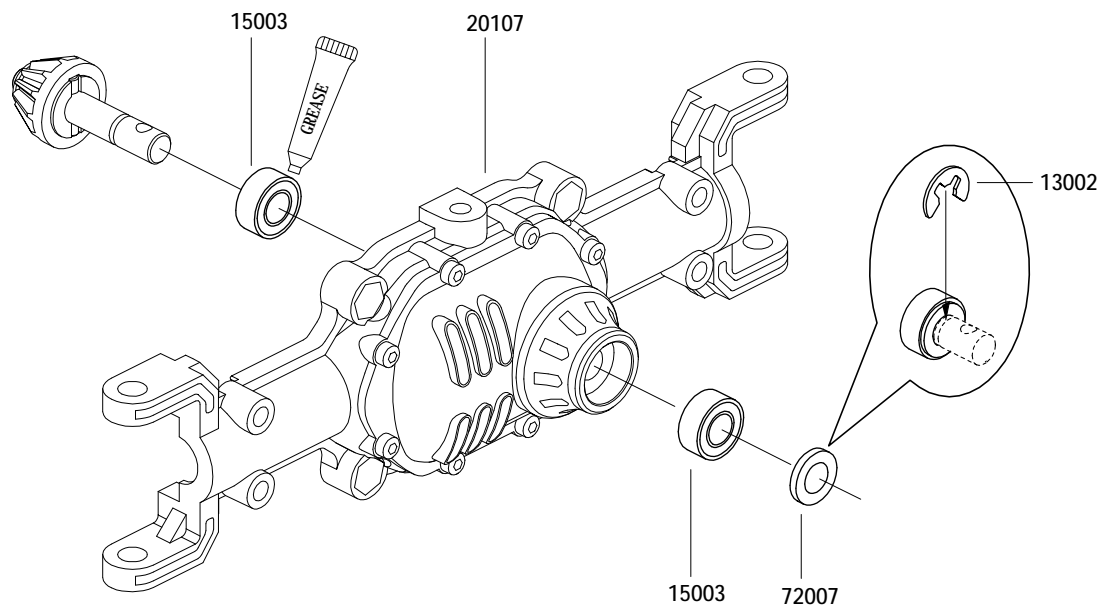

X2

MC6B

15 The first axle

12203  M3 X1

11601  M3x16 X1

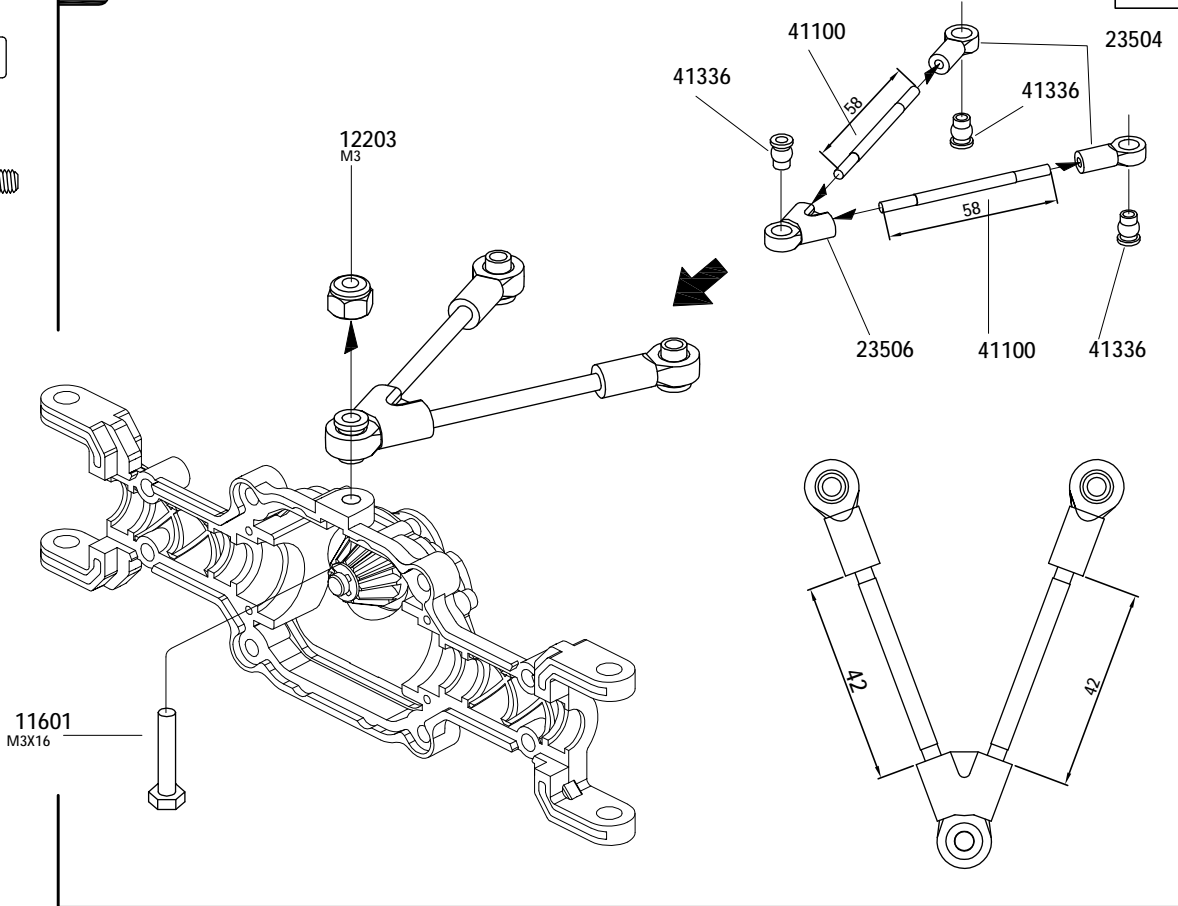



12203  M3 X4

11108  M3x12 X4

15003  $\phi 5 \times \phi 10 \times 4$ X2

15004  $\phi 10 \times \phi 15 \times 4$ X2

13002  $\phi 4 \times \phi 9 \times 0.6$ X2

72008  $\phi 10.2 \times \phi 15 \times 0.2$ X2

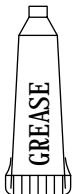

16 The first axle

MC6B

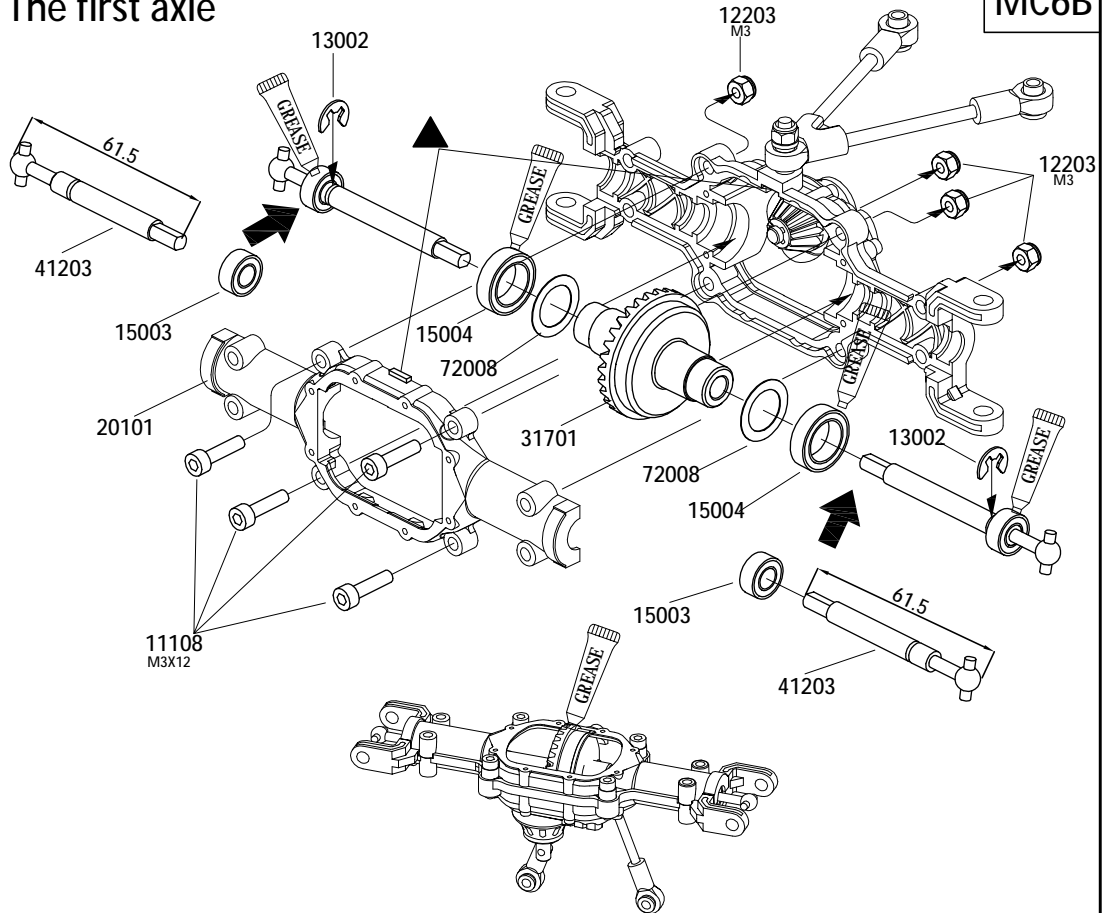

17 The first axle

MC6B

11102  M2x6 X8

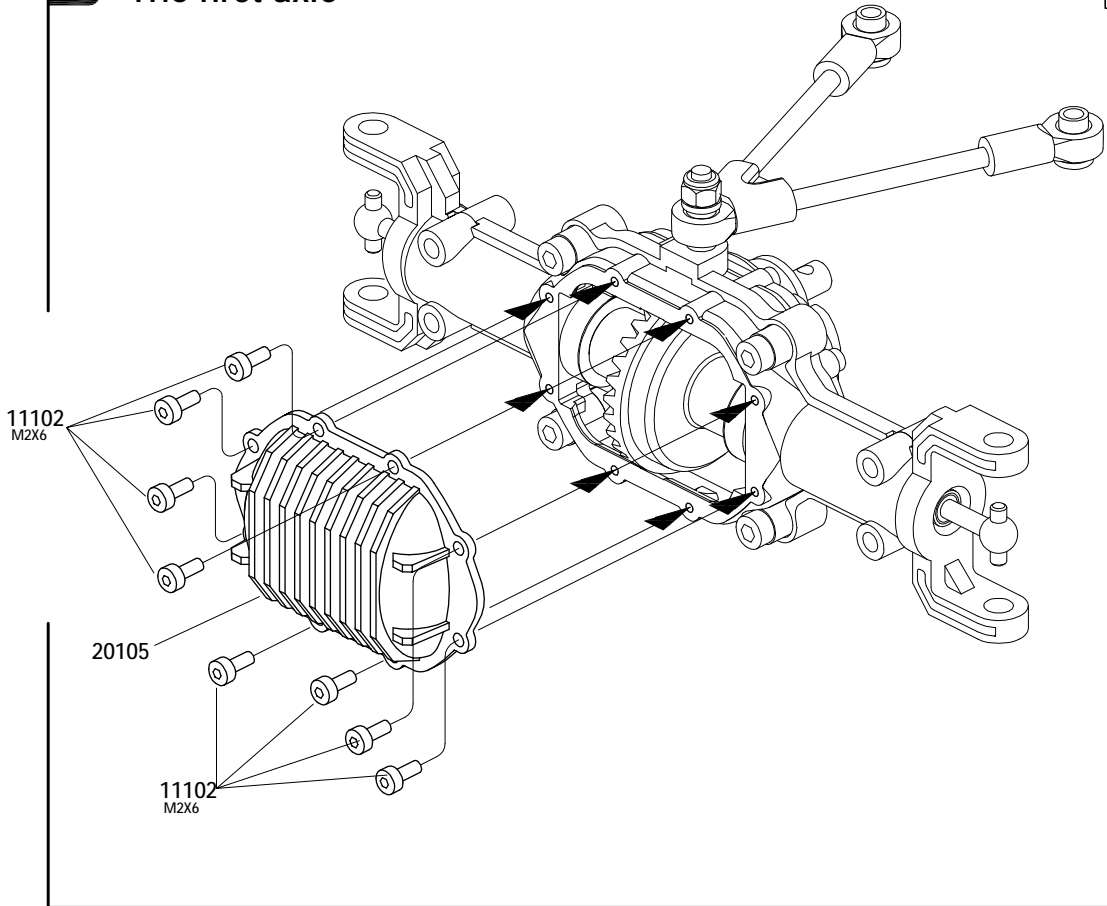

18 The first axle

MC6B

11107  M3x10 X4

15003  $\phi 5x\phi 10x4$ X2

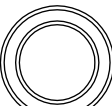
15004  $\phi 10x\phi 15x4$ X2

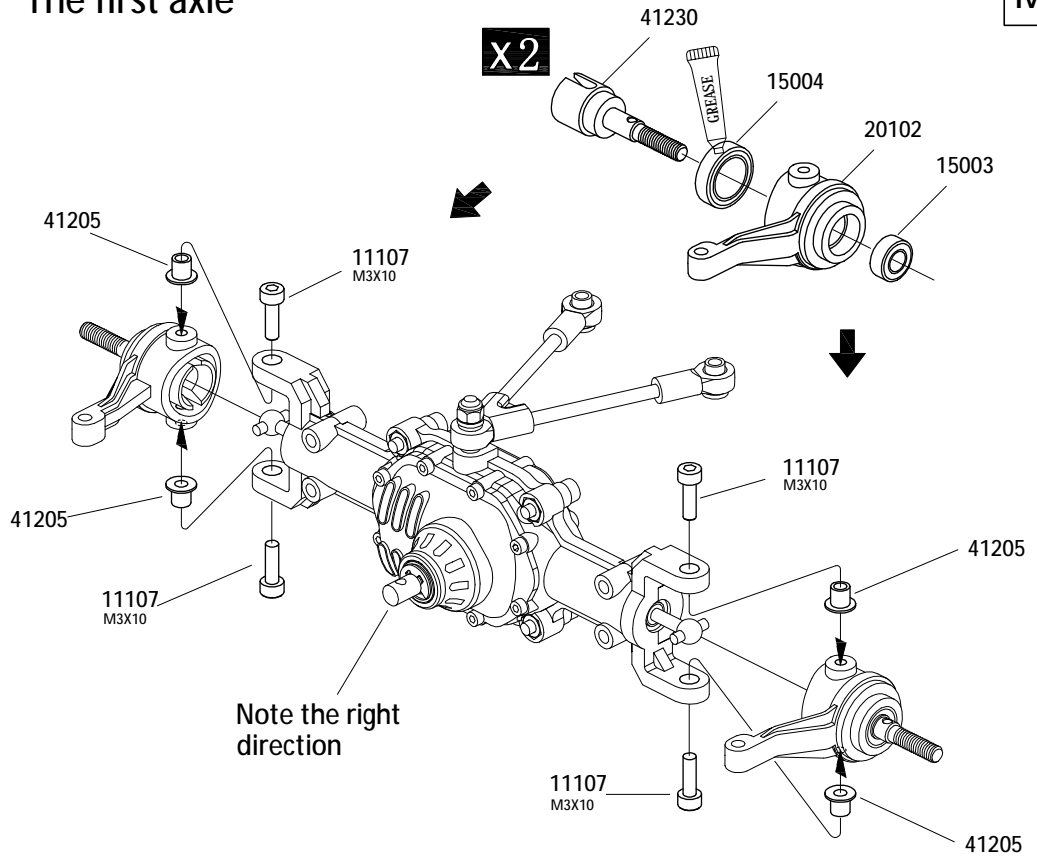

19

MC6B

The third axle



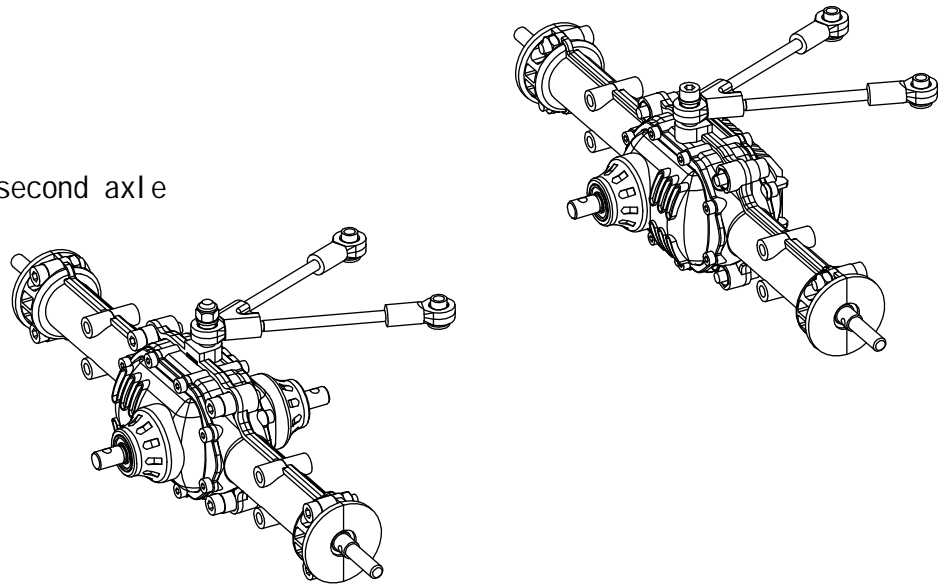



The second axle



20

The second and third axles

MC6B

- 15003  
 $\phi 5 \times \phi 10 \times 4$ X4
- 13002  
 $\phi 4 \times \phi 9 \times 0.6$ X2
- 72007  
 $\phi 5 \times \phi 8 \times 0.3$ X2

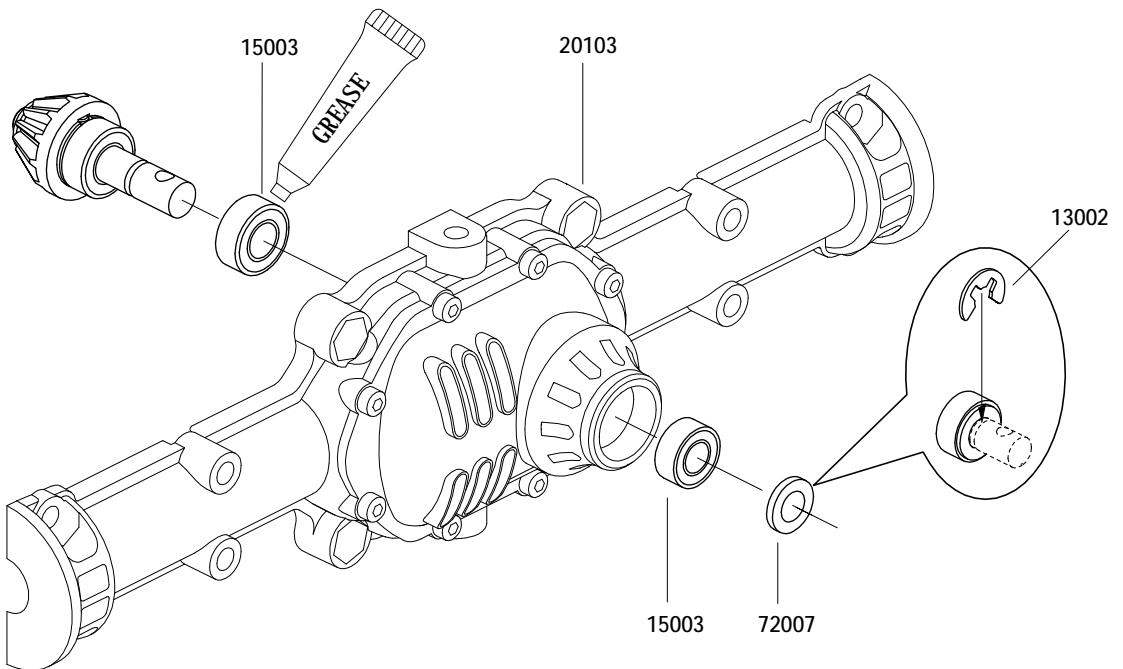

X2



21 The second and third axles

MC6B

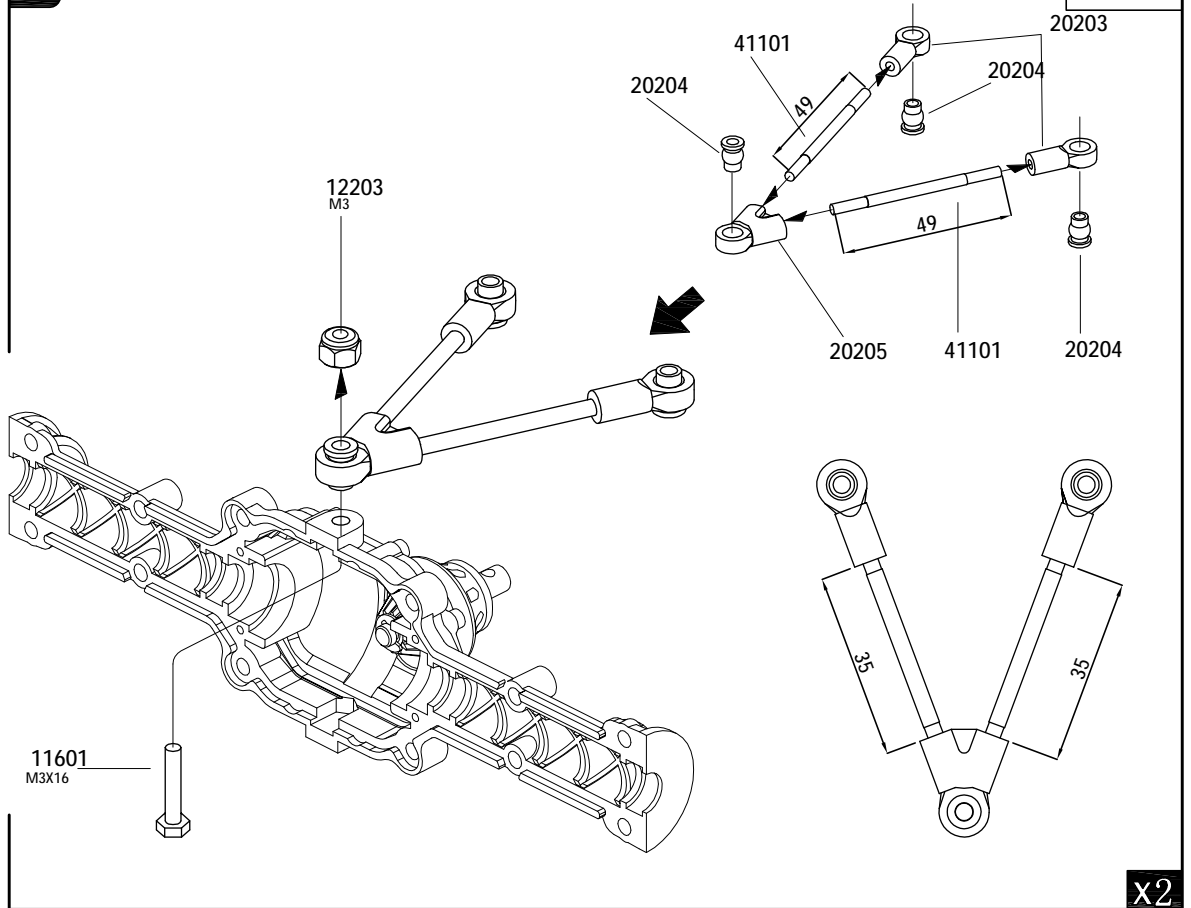

12203  
M3 X2



11601 
M3x16 X2





12203  
M3 X16

11108 
M3x12 X16

15003  
φ5xφ10x4 X4

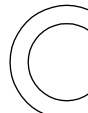
15004  
φ10xφ15x4 X4

72008  
φ10.2xφ15x0.2 X4



22 The second and third axles

MC6B

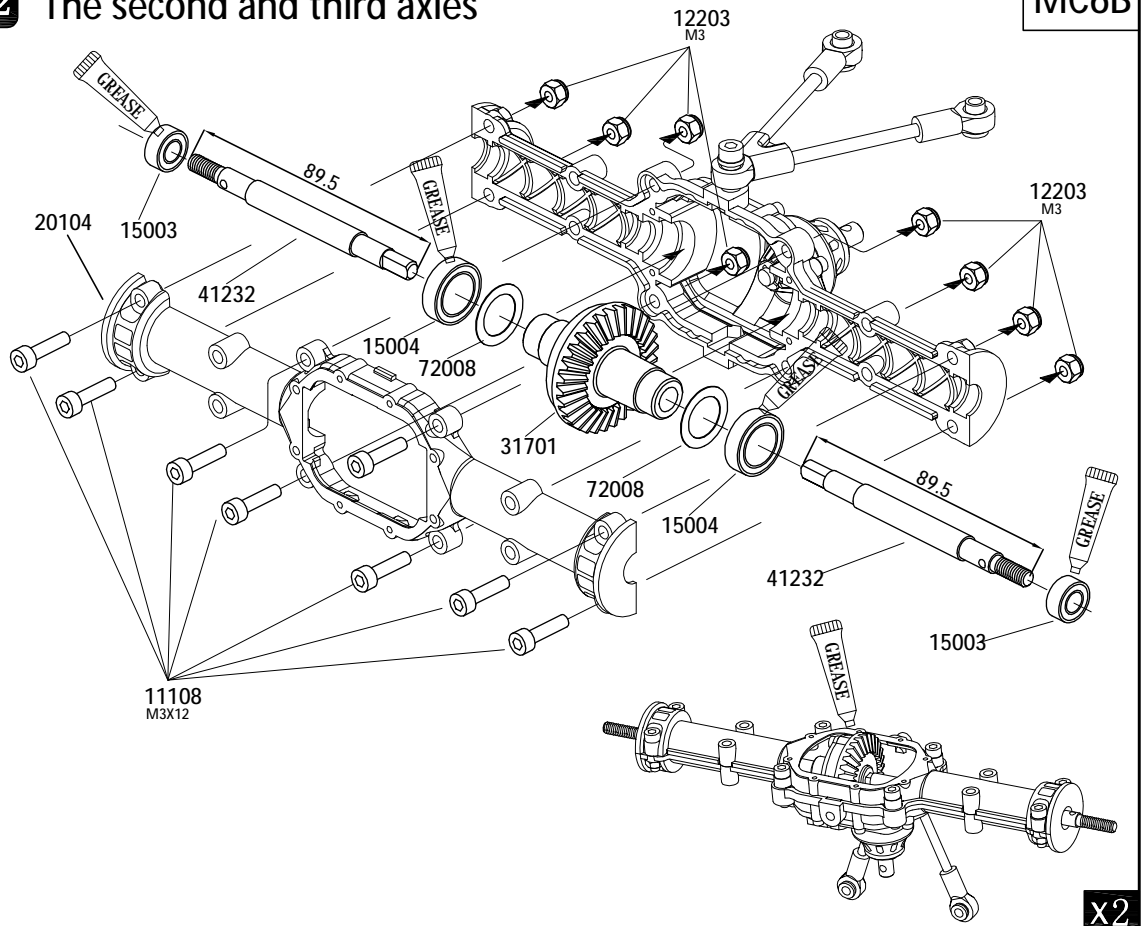

23 The second axle

MC6B

11102 
M2x6 X8

15003 
φ5xφ10x4 X2

13002 
φ4xφ9x0.6 X1

72007 
φ5xφ8x0.3 X1

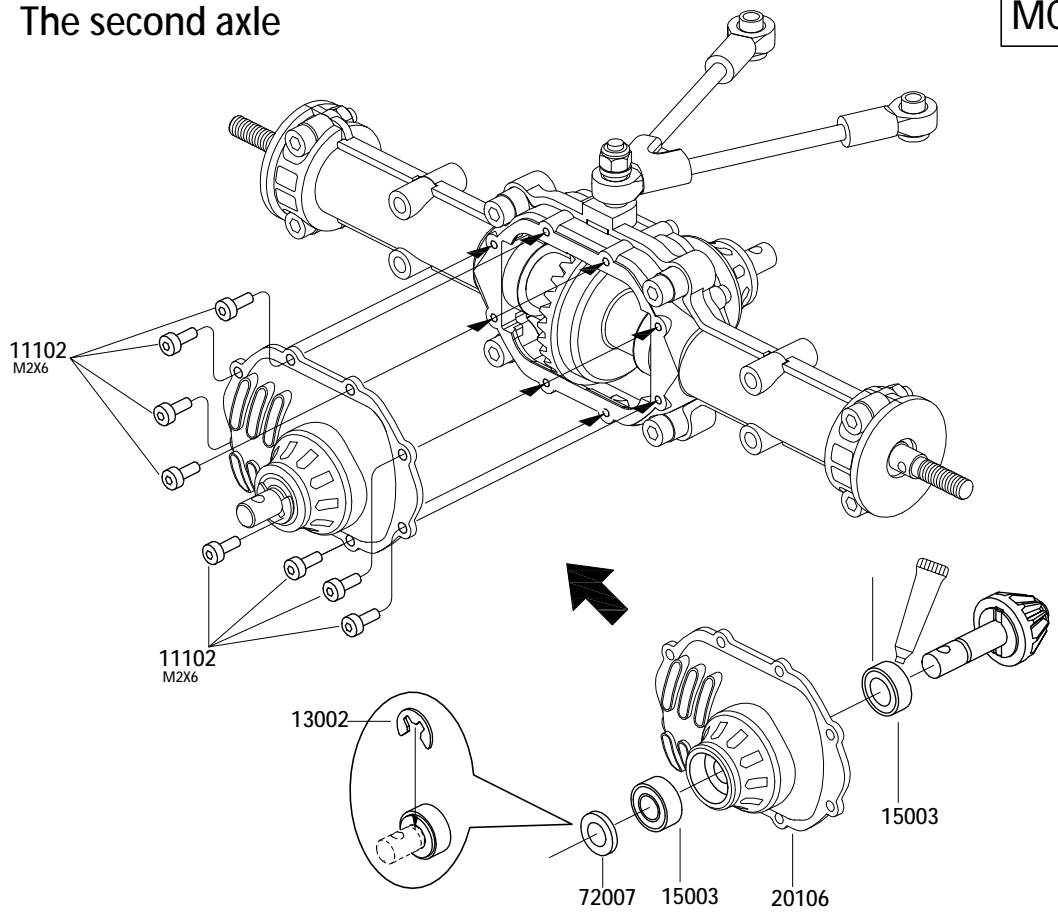

24 The third axle

MC6B

11102 
M2x6 X8

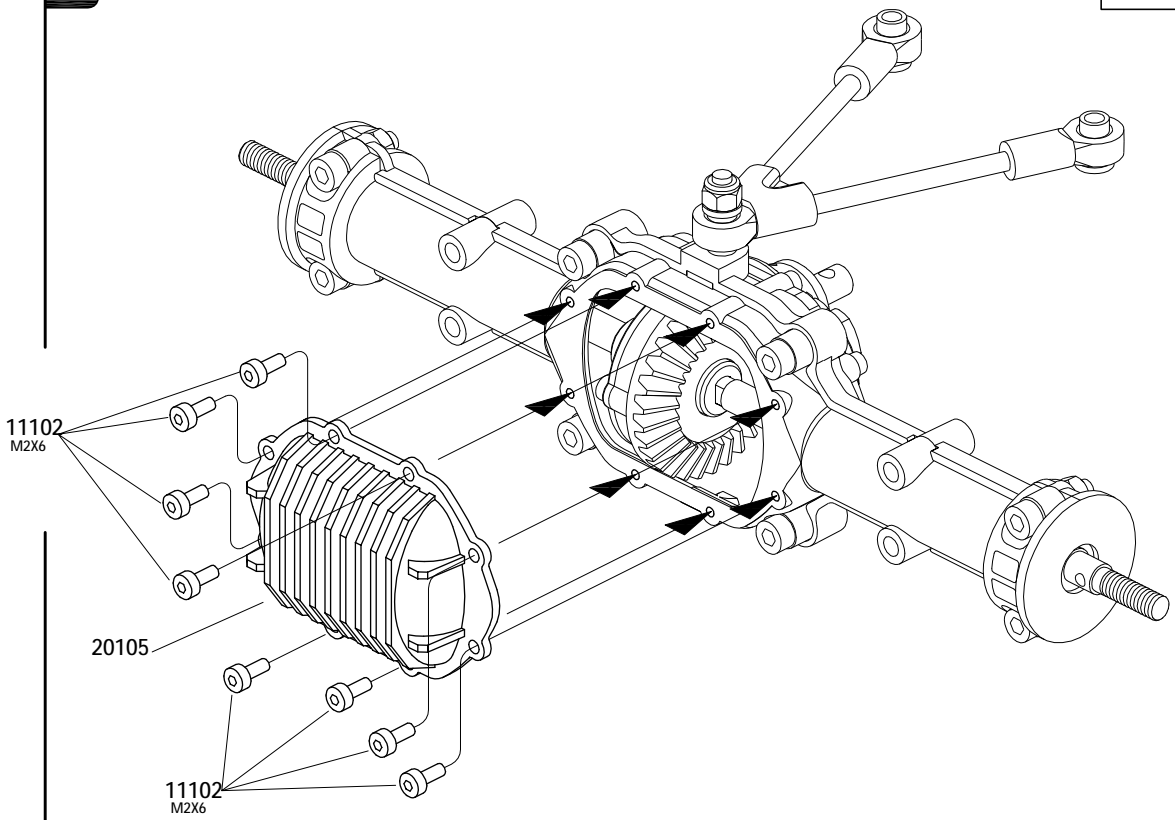

25 The first axle

MC6C

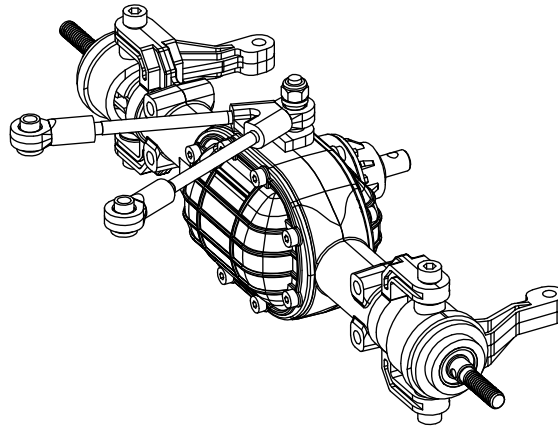

The first axle





12203  
M3 X1

11405  
M4x4 X1

15003  
ø5xø10x4 X2

13002  
ø3.8xø9.2x0.6 X1

11601 
M3x16 X1

72007  
ø5xø8x0.3 X1





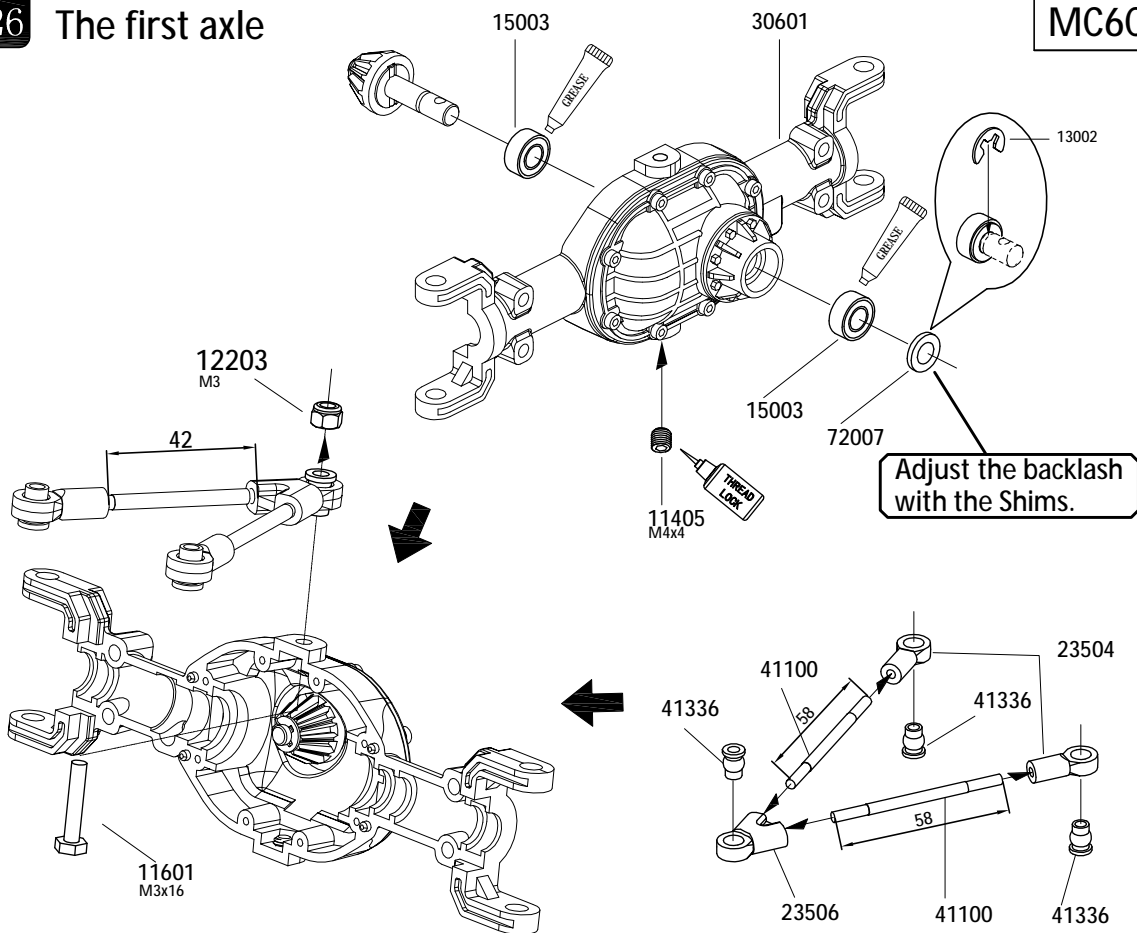

26 The first axle

MC6C



27 The first axle

MC6C

- 15003  $\phi 5 \times \phi 10 \times 4$ X2
- 15004  $\phi 10 \times \phi 15 \times 4$ X2
- 13002  $\phi 3.8 \times \phi 9.2 \times 0.6$ X2
- 72008  $\phi 10.2 \times \phi 15 \times 0.2$ X2
-  GREASE

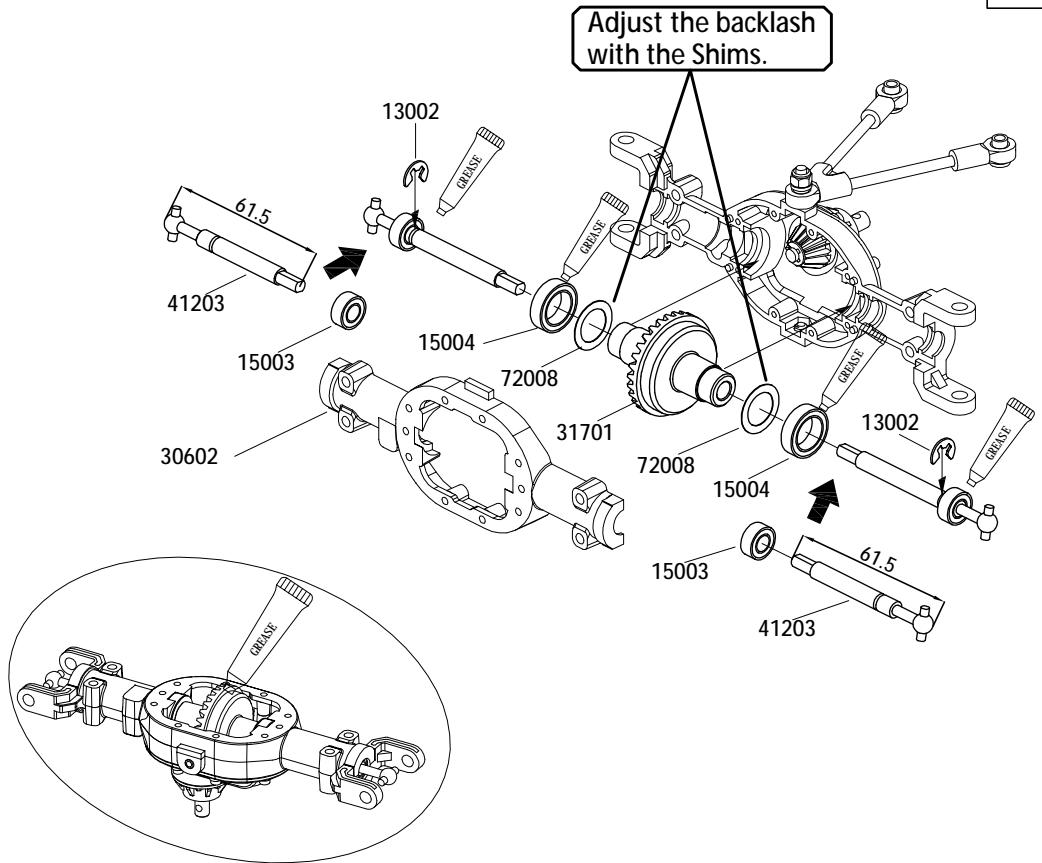

28 The first axle

MC6C

- 11126  M2x14 X8
-  THREAD LOCK

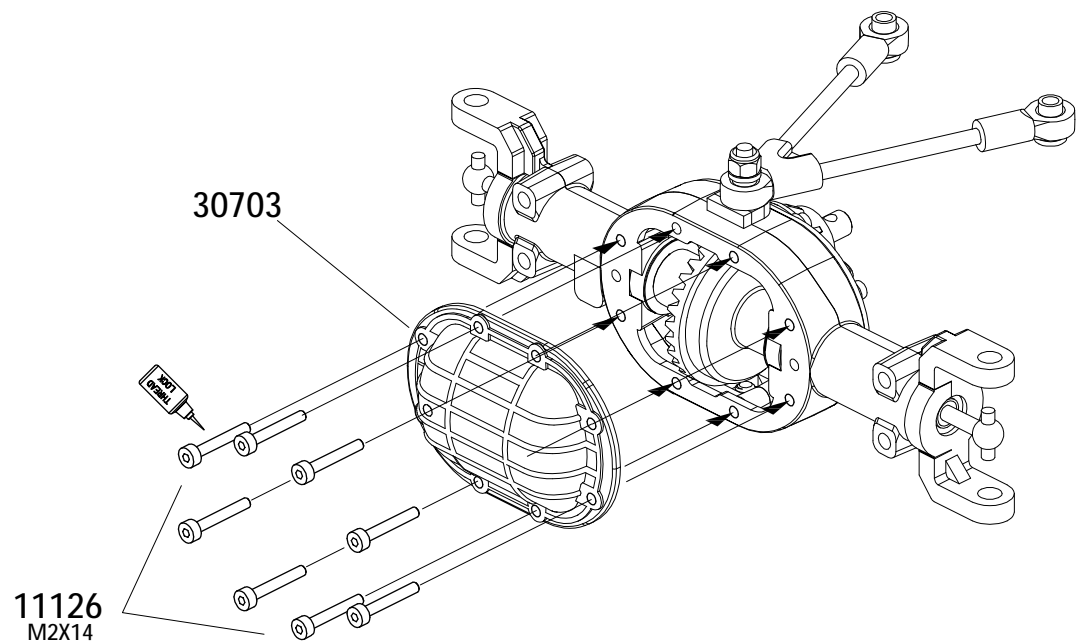

29 The first axle

MC6C



M3x10 X4

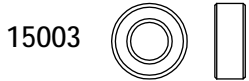

ø5xø10x4 X2

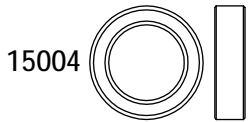

ø10xø15x4 X2

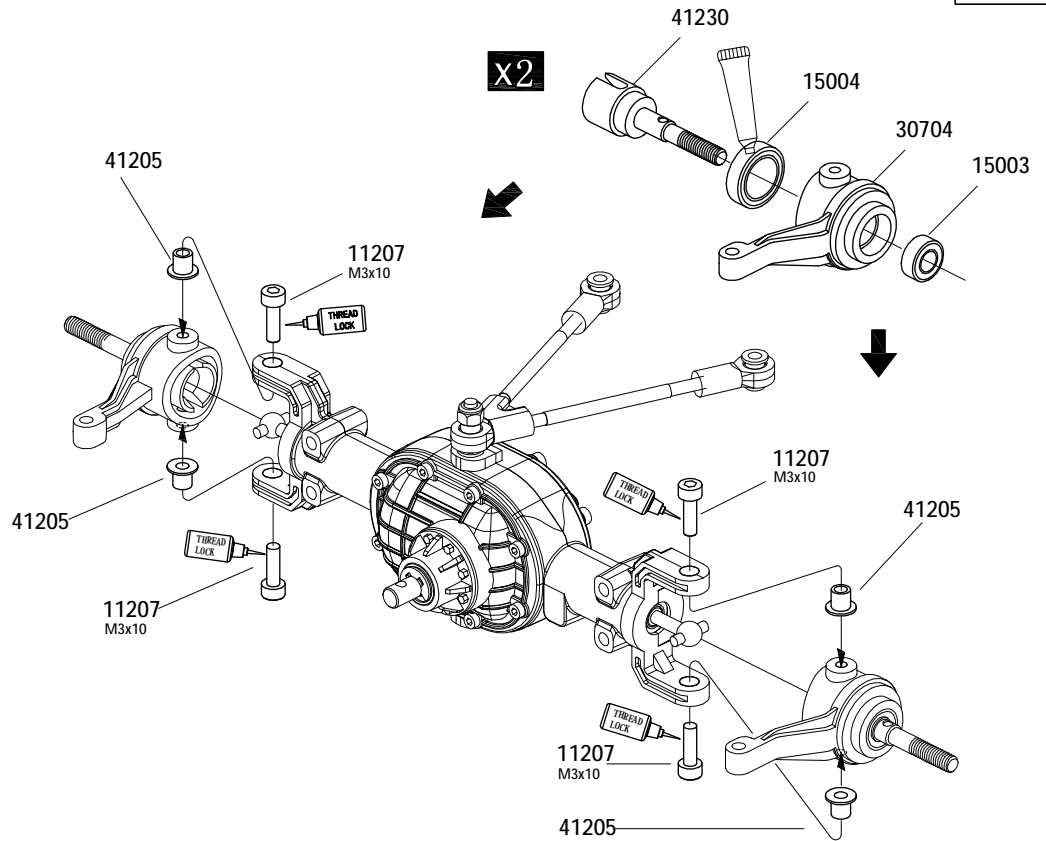
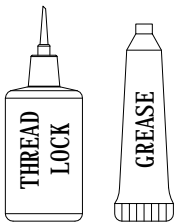





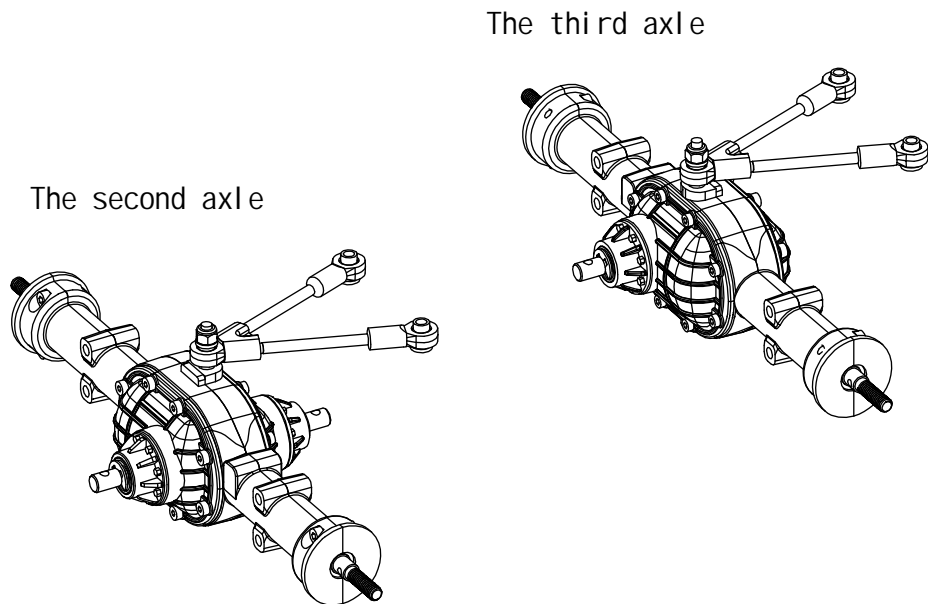



30 The second and third axles

MC6C



31

The second and third axles MC6C

- 12203  
M3 X2
 - 11405  X2
 - 11601  X2
M3x16 X2
 - 15003  
φ5xφ10x4 X4
 - 13002  X2
φ3.8xφ9.2x0.6 X2
 - 72007  X2
φ5xφ8x0.3 X2
- 

THREAD
LOCK





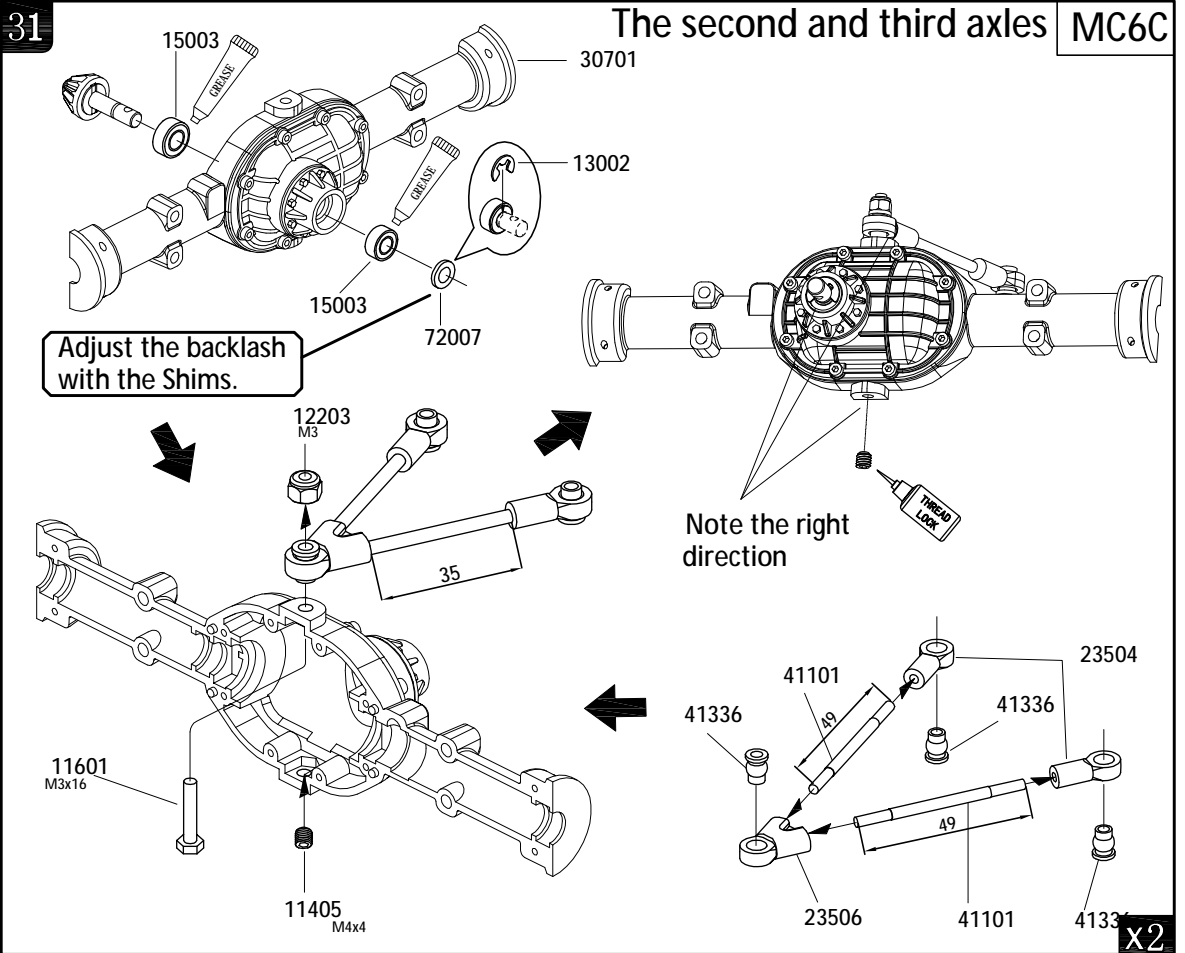



GREASE



32

The second and third axles

MC6C

- 11125  X8
M2.5x10 X8
 - 15003  
φ5xφ10x4 X4
 - 15004  
φ10xφ15x4 X4
 - 72008  X4
φ10.2xφ15x0.2 X4
- 

THREAD
LOCK



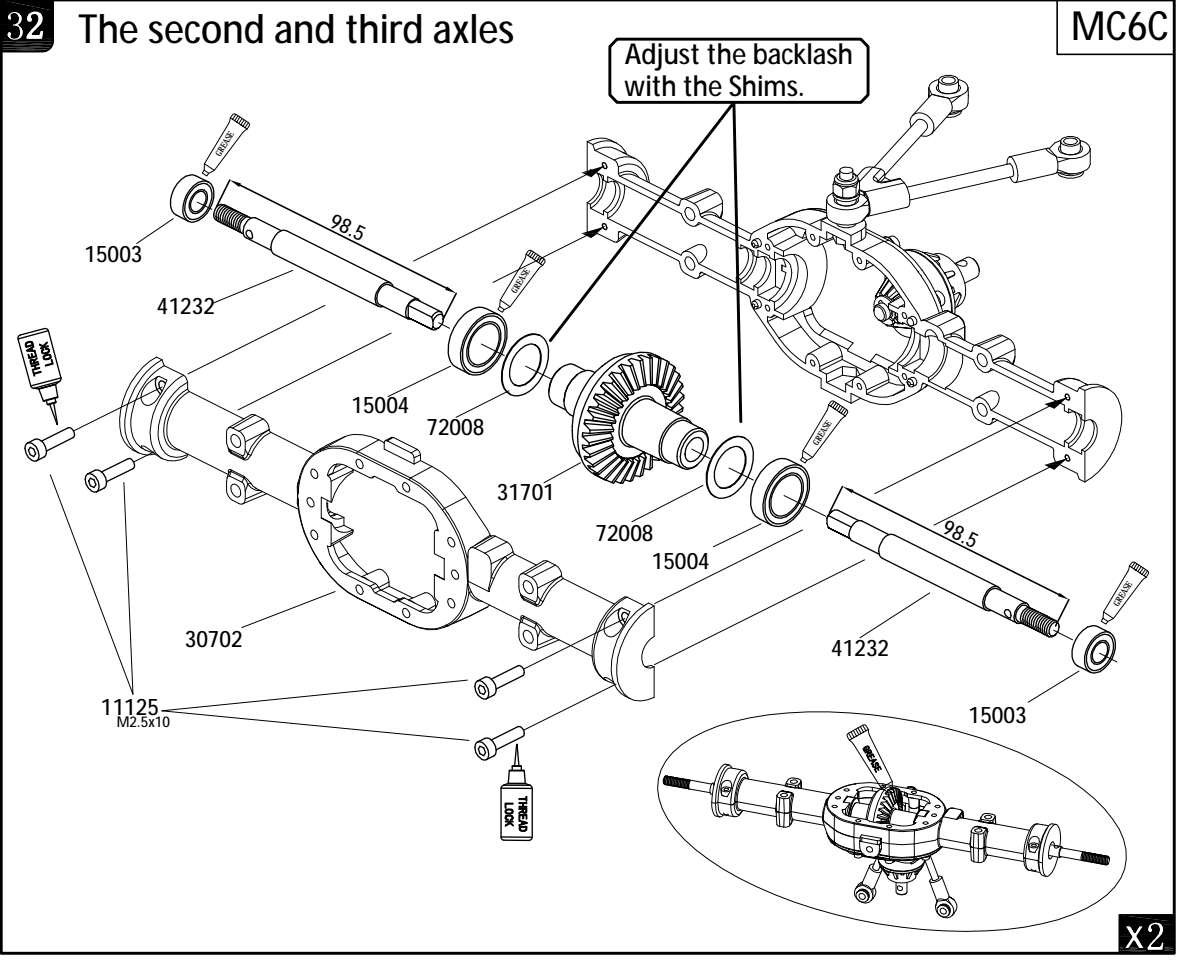

GREASE





MC6C

33 The second axle

11126 
M2x14 X8

15003 
φ5xφ10x4 X2

13002 
φ3.8xφ9.2x0.6 X1

72007 
φ5xφ8x0.3 X1

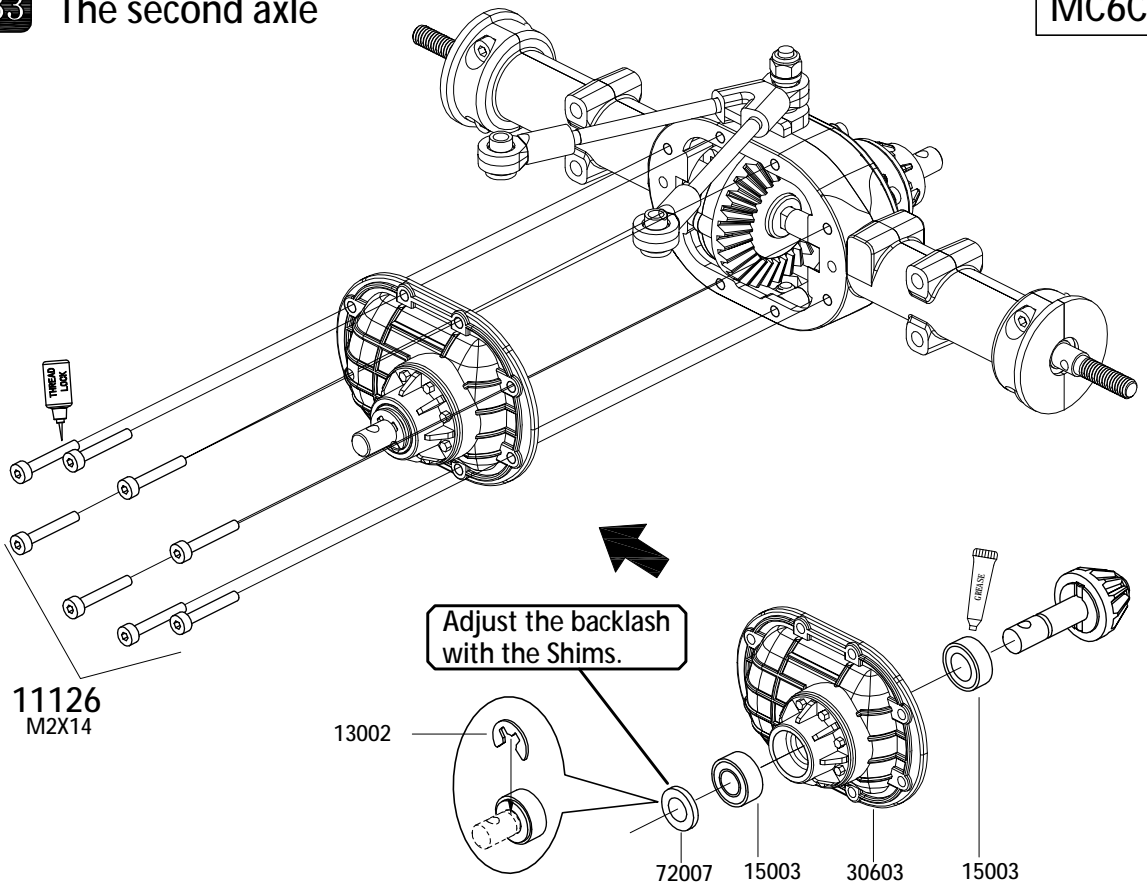

34 The third axle

MC6C

11126 
M2x14 X8

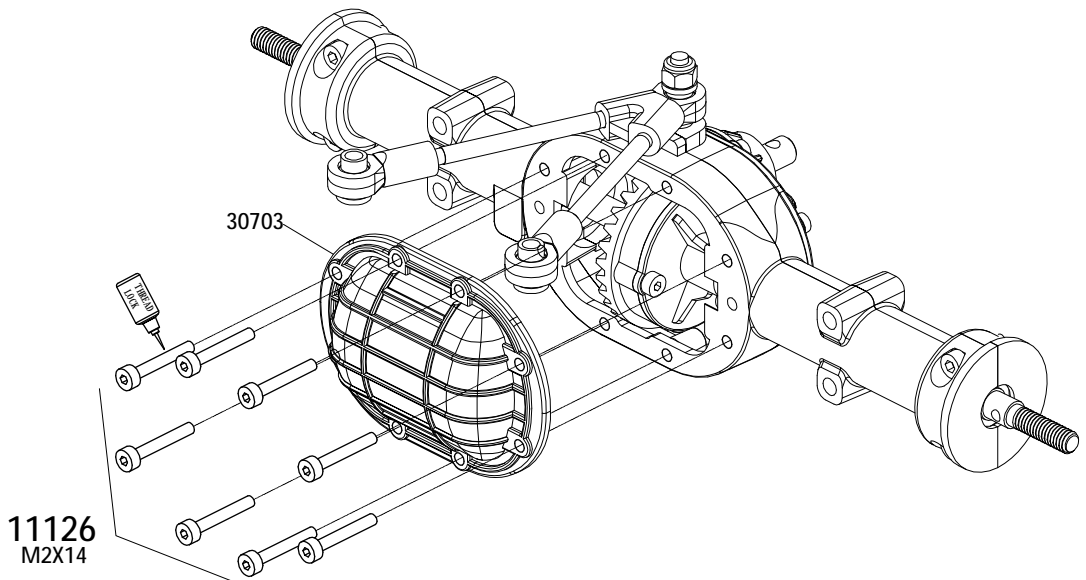

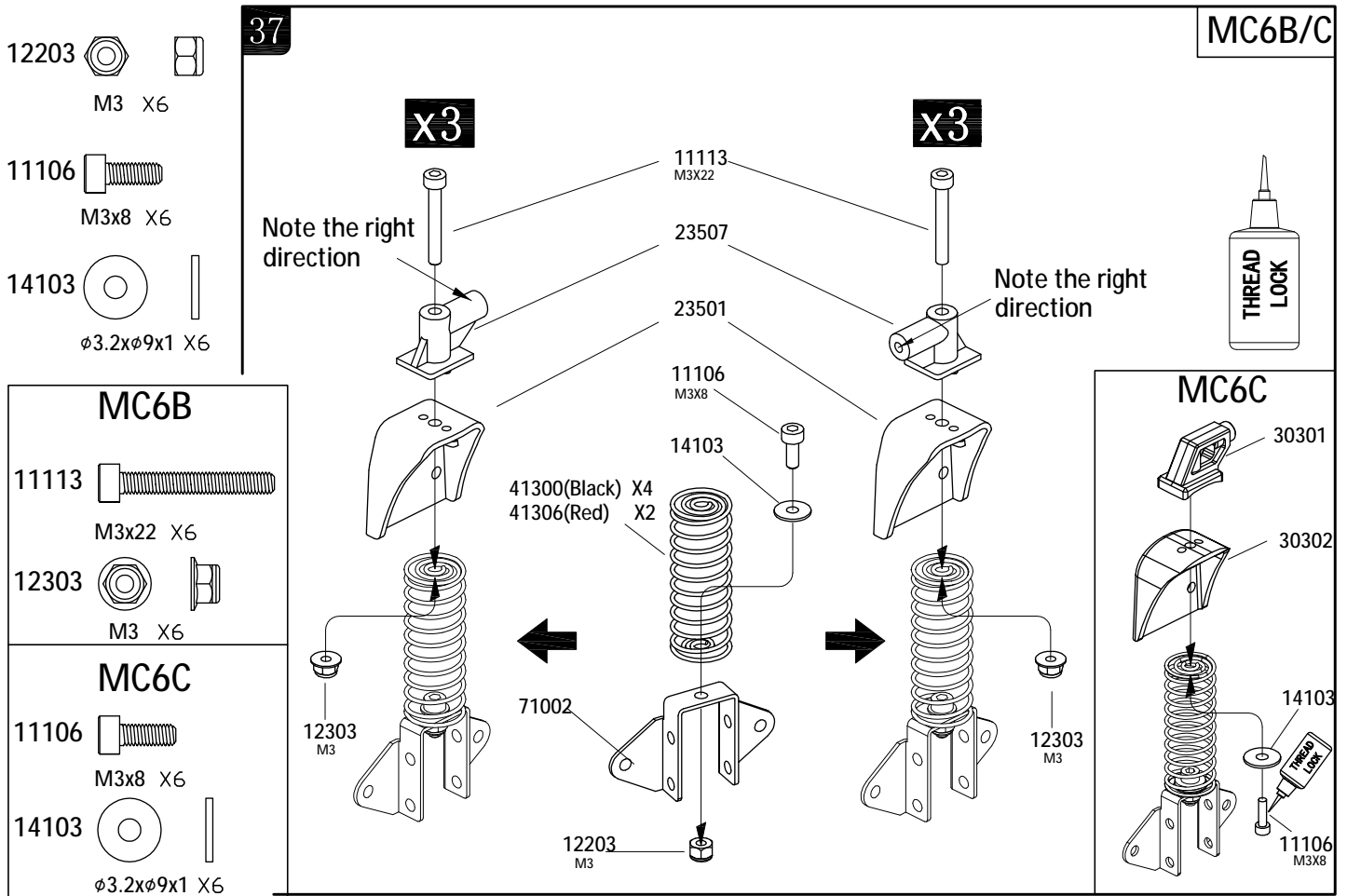
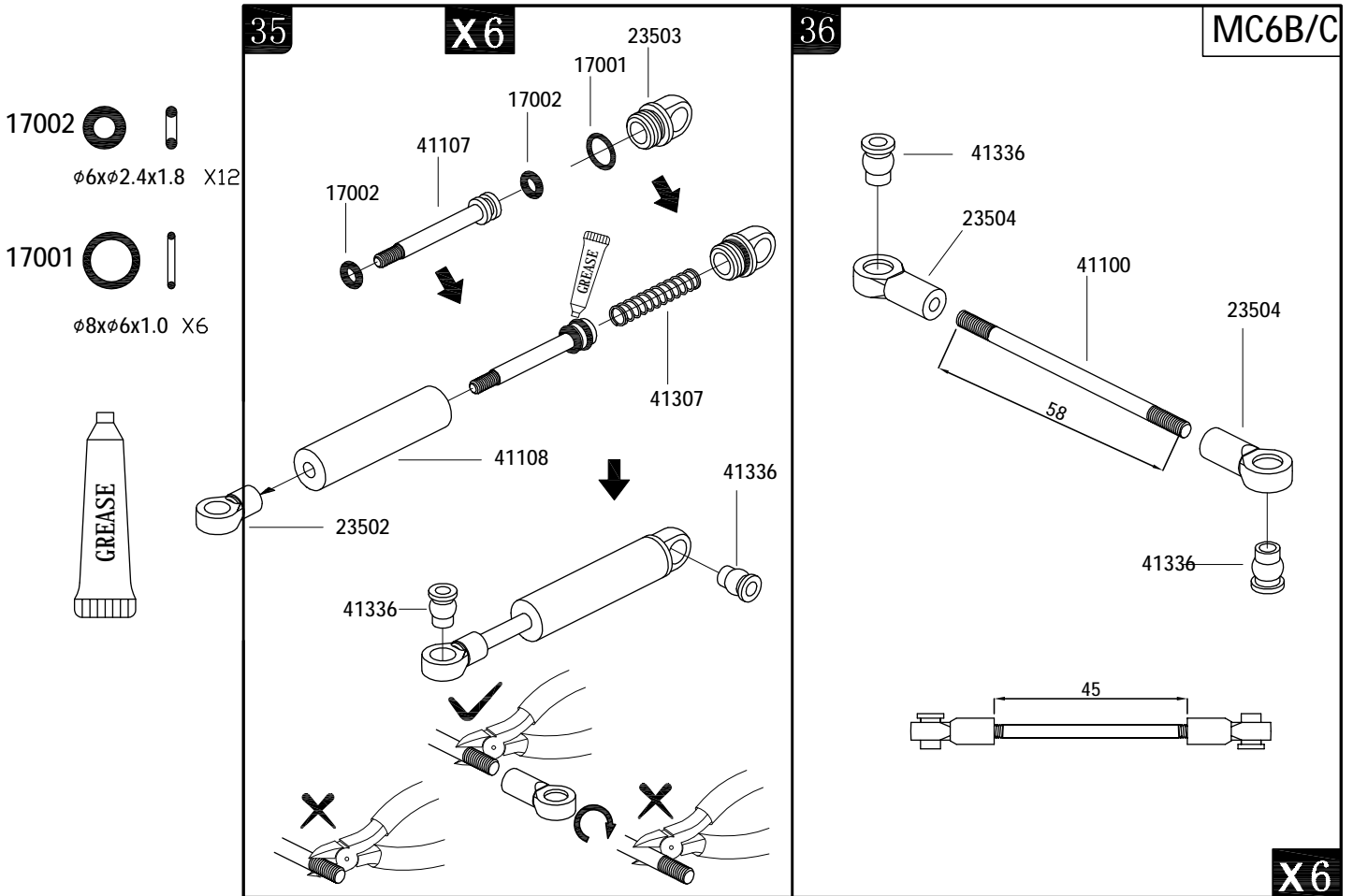

38

MC6B/C

12203  
M3 X12

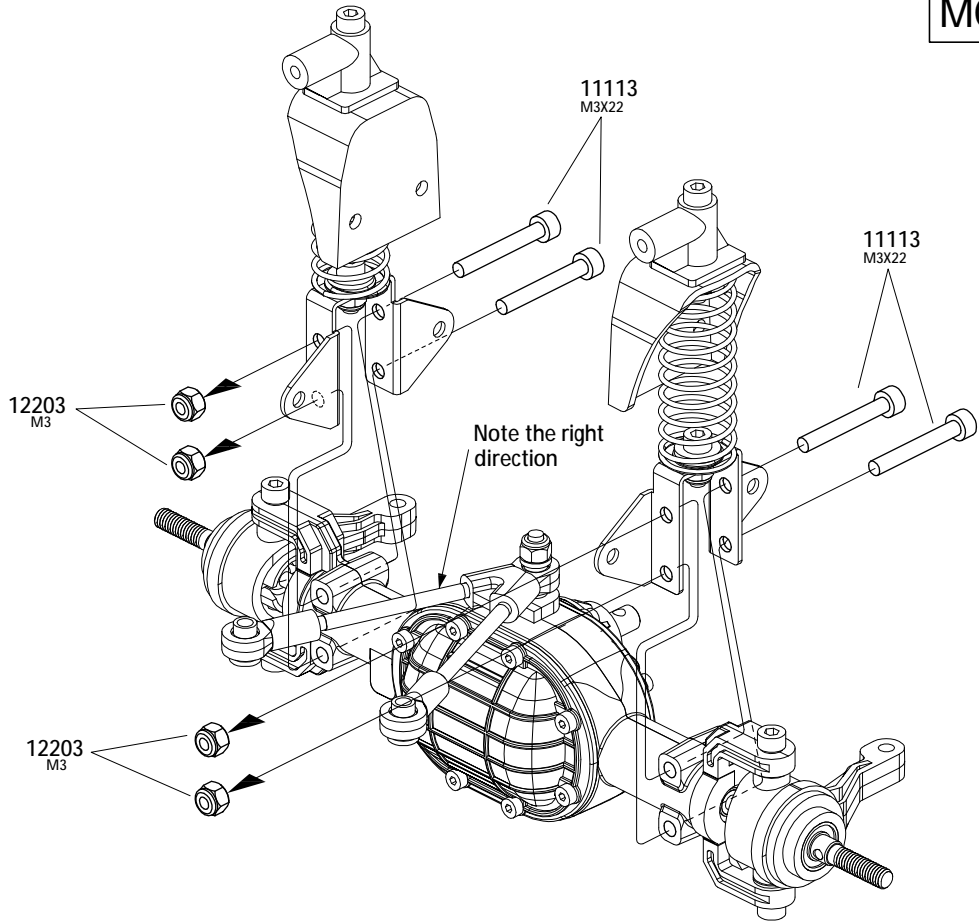

11113 
M3x22 X12



X3

39

MC6B/C

12203  
M3 X6

11109 
M3x14 X12

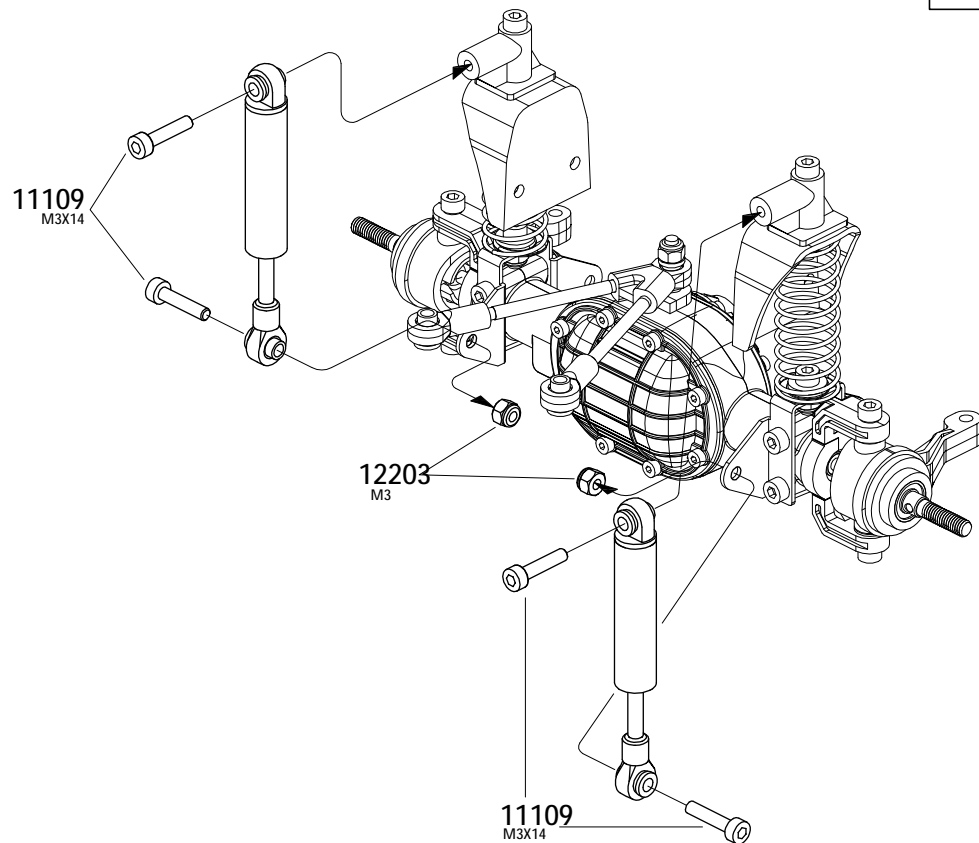

X3

11109 
M3x14 X2

12203 
M3 X2



40 The first axle

MC6B/C

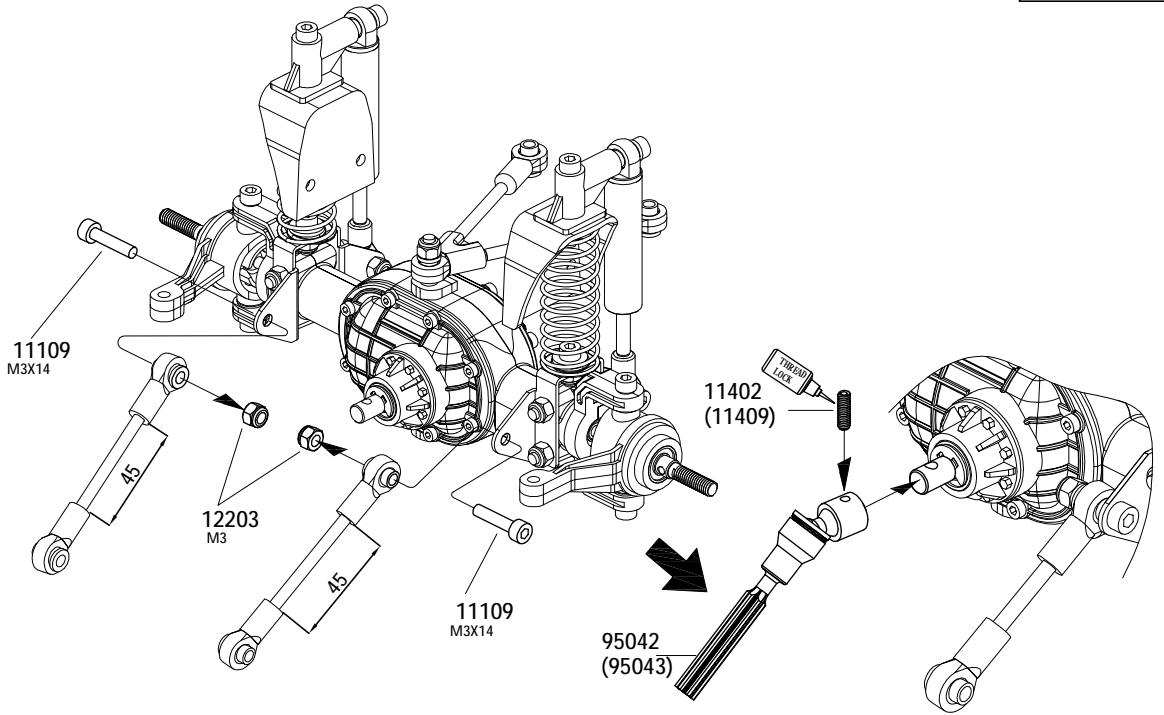

11409 
M3x10 X1

MC6B

11402 
M3x10 X1

MC6C

95042  X1

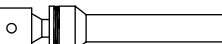
95043  X1

11109 
M3x14 X2

12203 
M3 X2



41 The second axle

MC6B/C

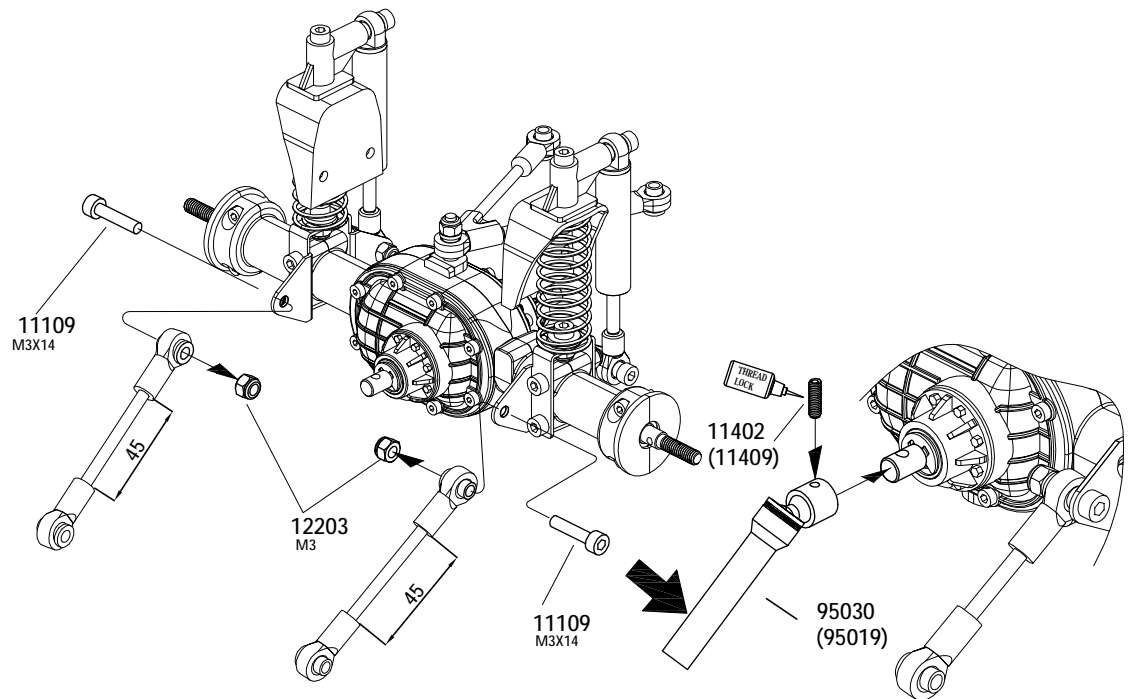

11409 
M3x10 X1

MC6B

11402 
M3x10 X1

MC6C

94041  X1

95019  X1

42 The second axle

MC6B/C

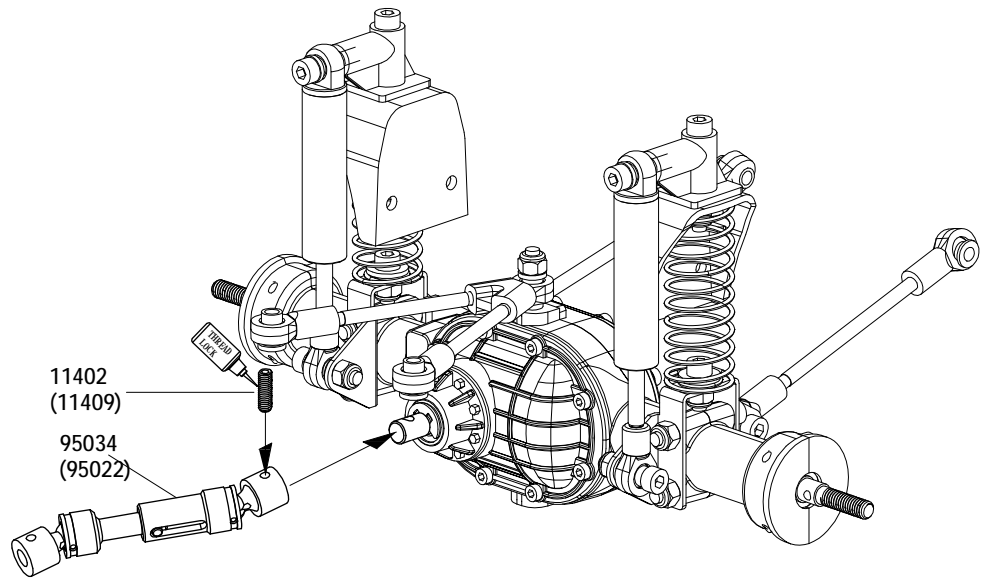

11409  M3x10 X1

MC6B

11402  M3x10 X1

MC6C

95034  X1

95022  X1

43 The third axle

MC6B/C



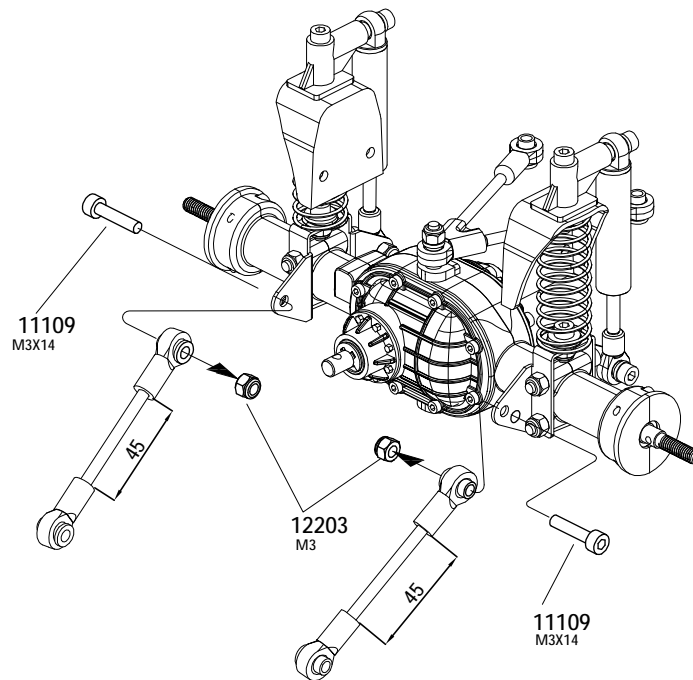

11109  M3x14 X2

12203   M3 X2



MC6B/C



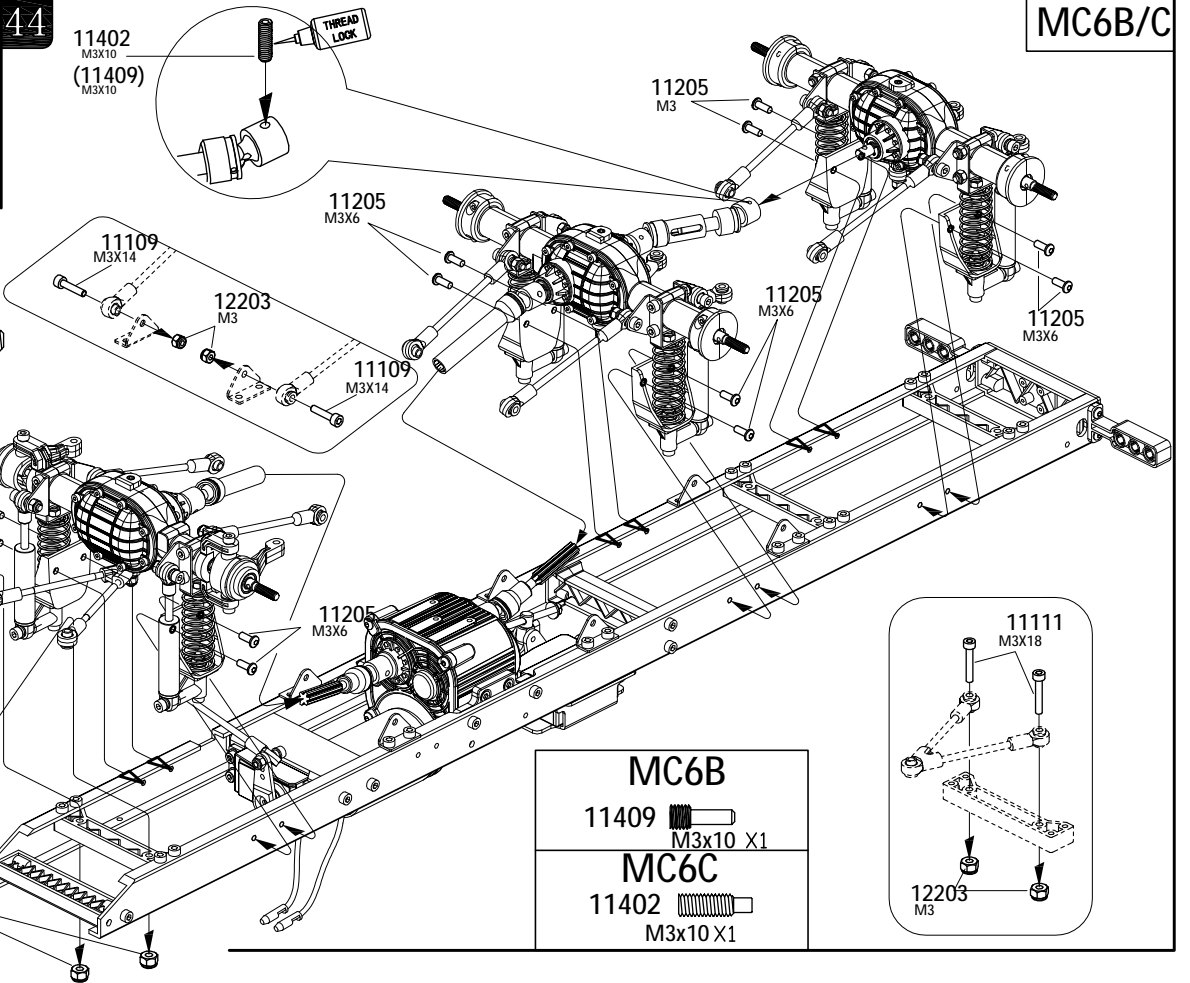

44

- 12203  
M3 X12
- 11205 
M3x6 X12
- 11109 
M3x14 X6
- 11111 
M3x18 X6



45

MC6B/C

- 11114 
M3x25 X1
- 11122 
M3x35 X1
- 12203  
M3 X2

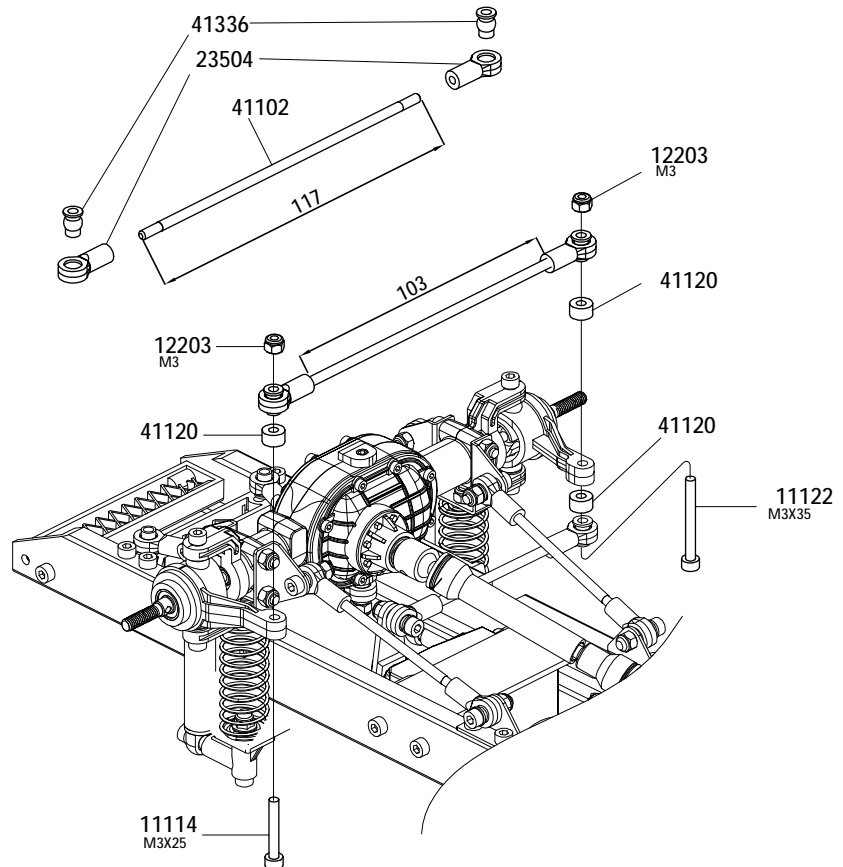

46

MC6B/C

12204 
M4 X6

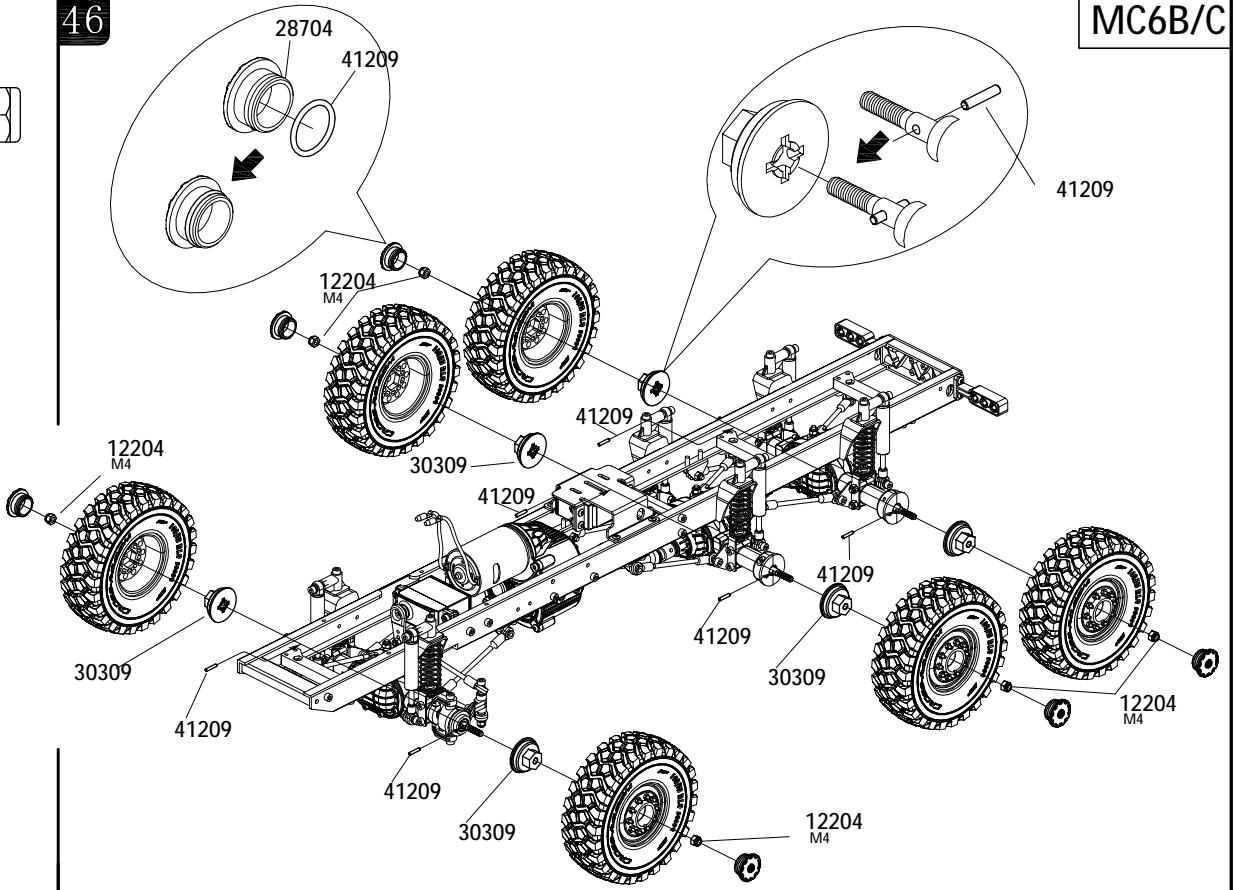

47

MC6B/C

11216 
M2.5x6 X1

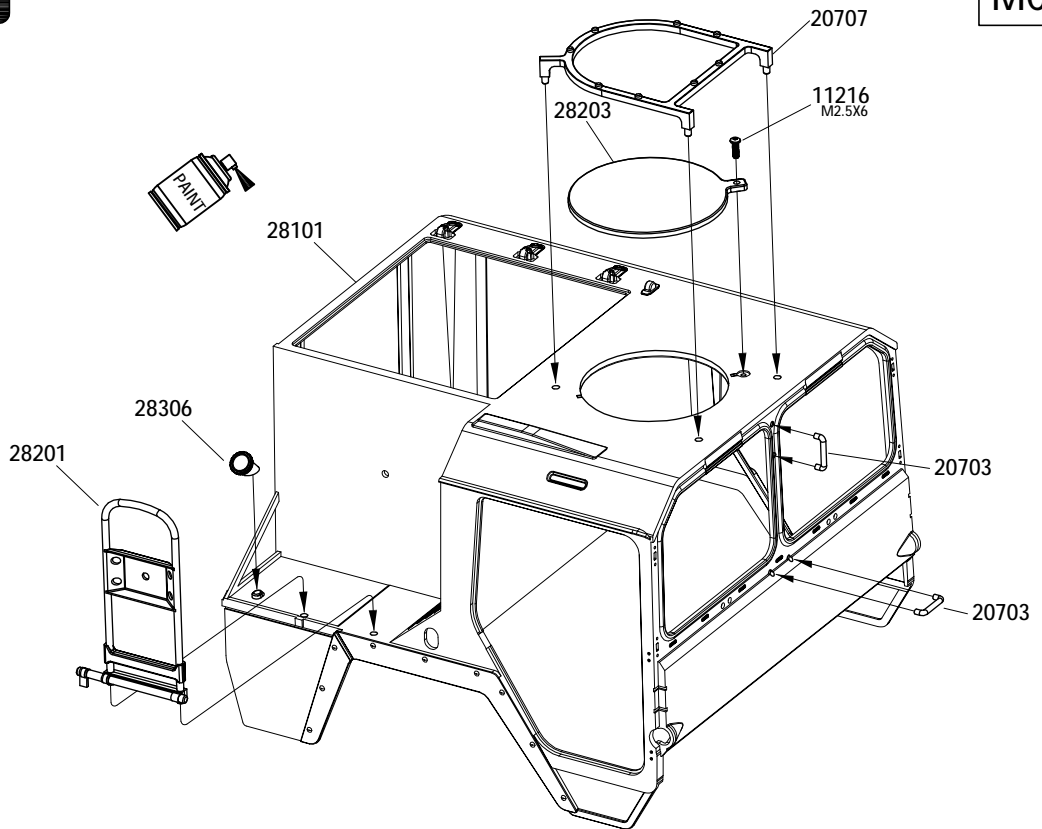

48

MC6B/C

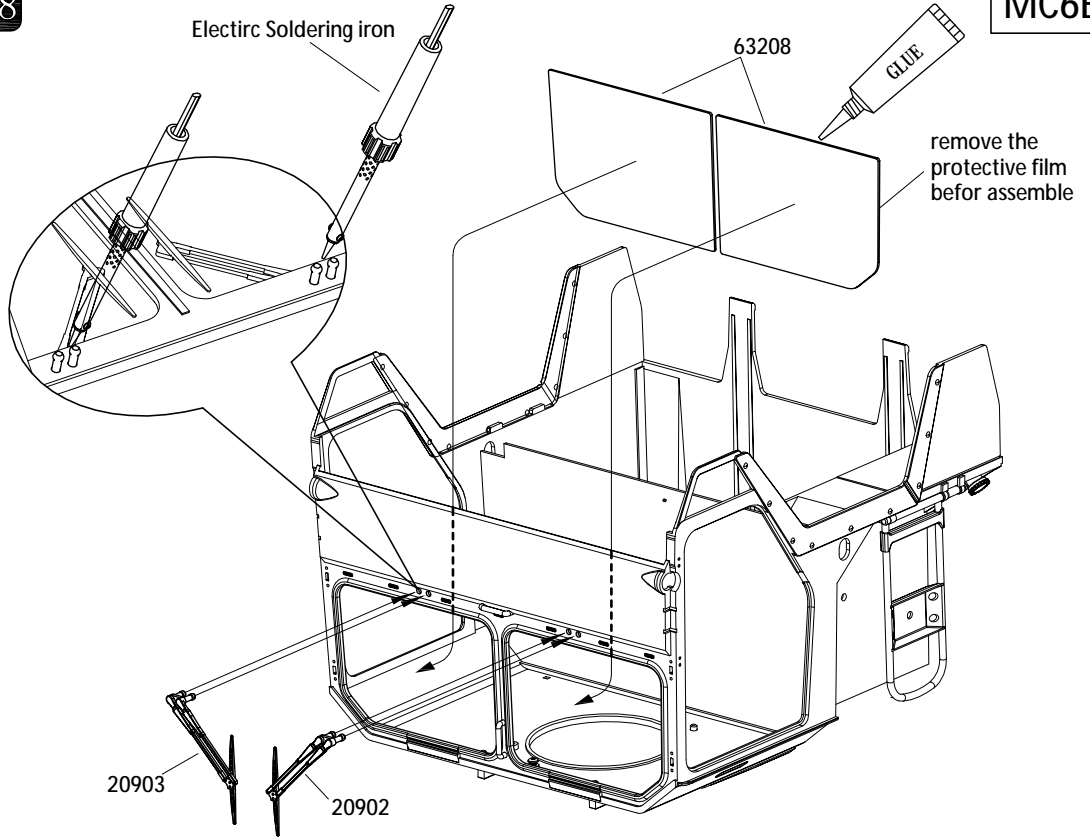

49

MC6B/C

11218 
M2.5x4 X2

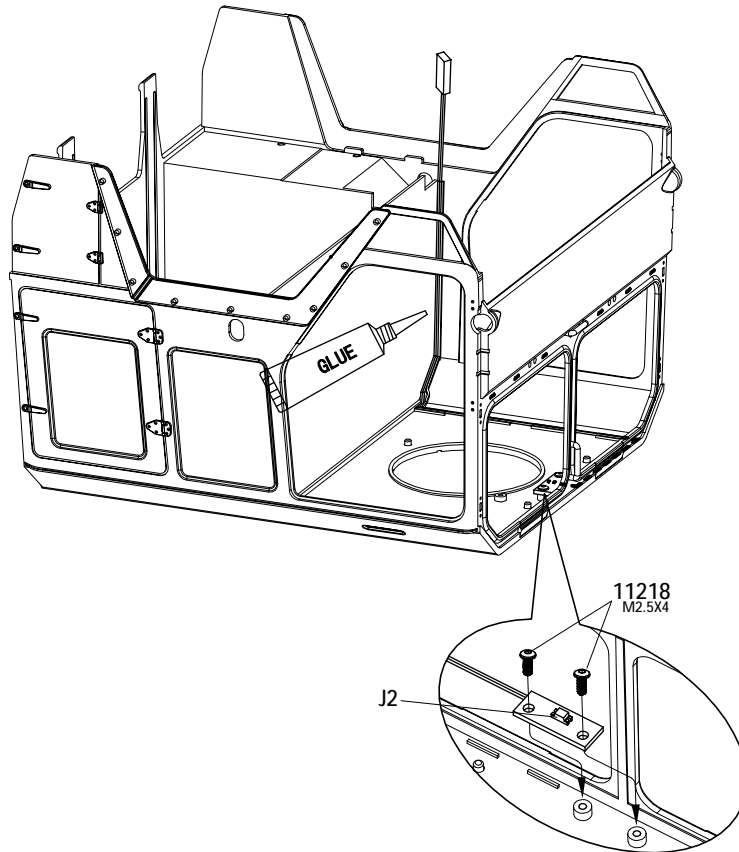
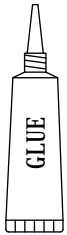

50

MC6B/C

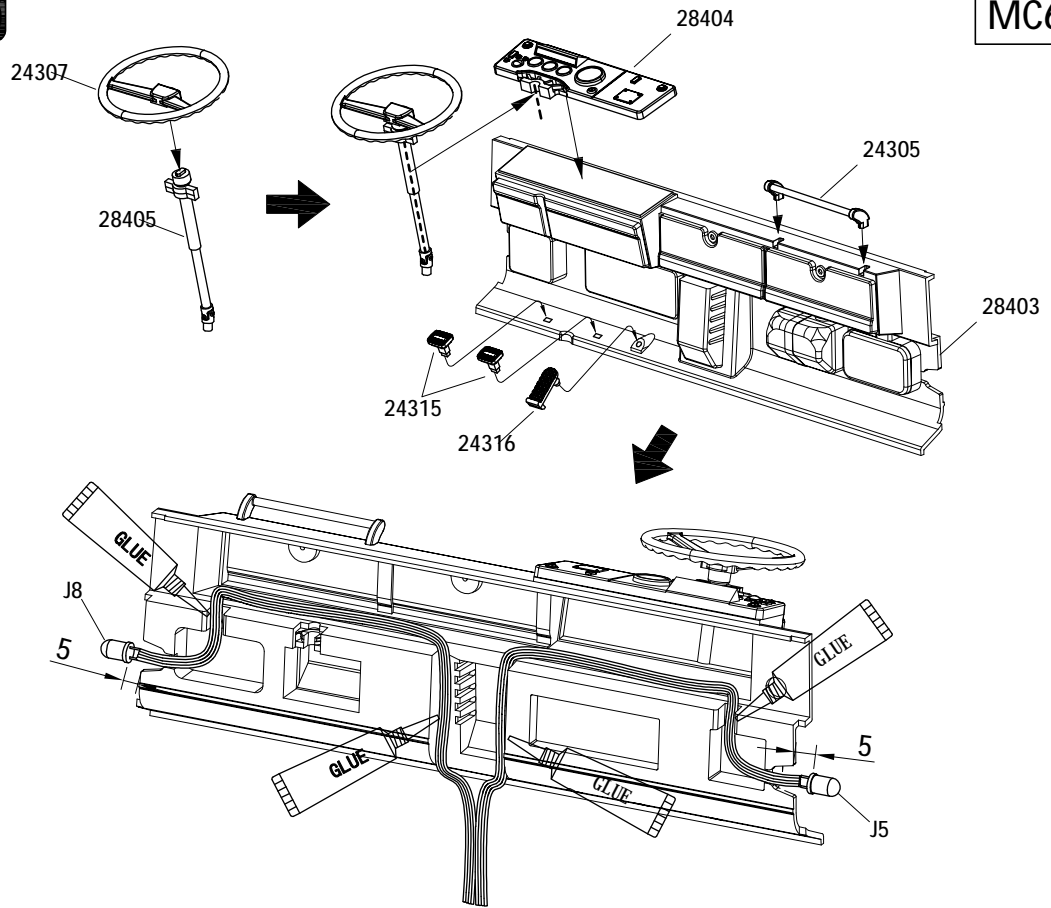
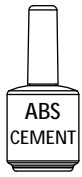

51

MC6B/C

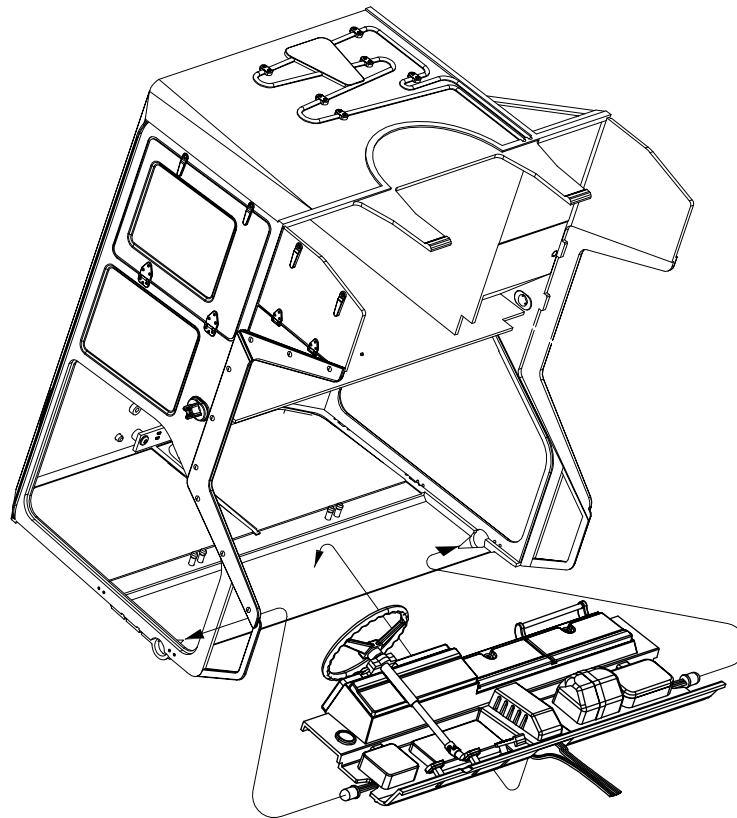

11205 
M3x6 X4

52

MC6B/C

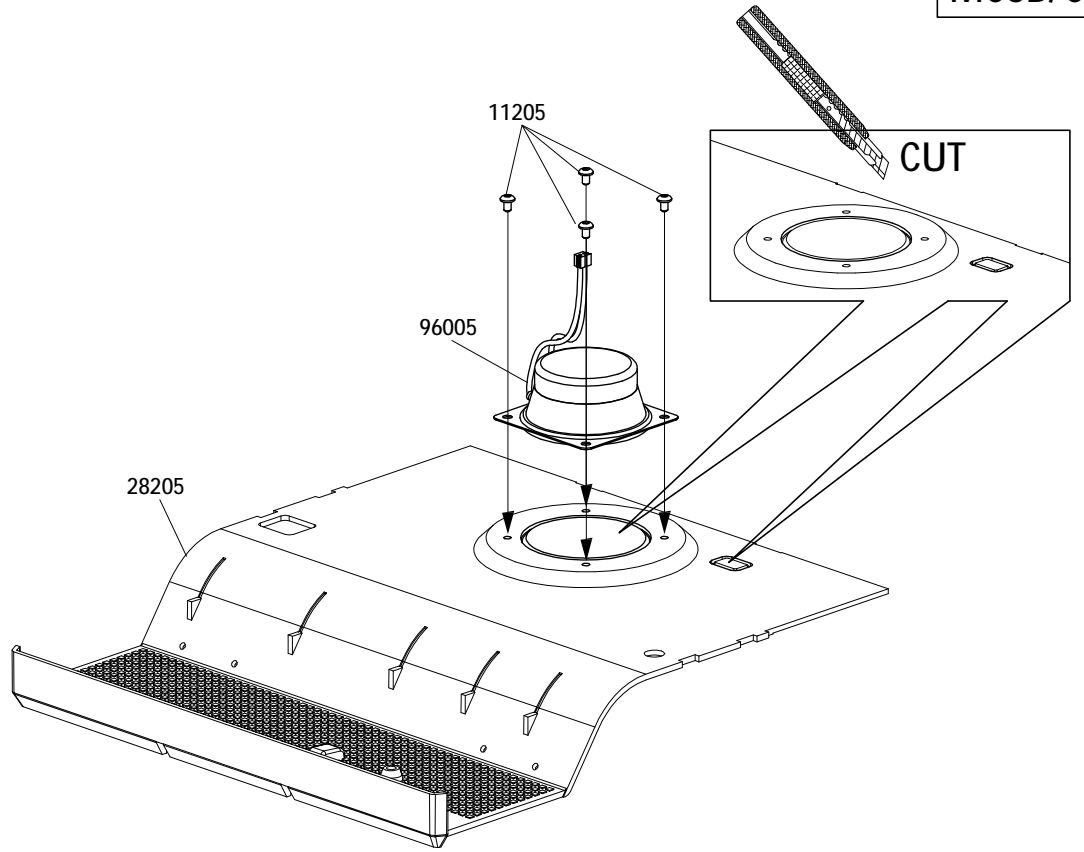

53

MC6B/C

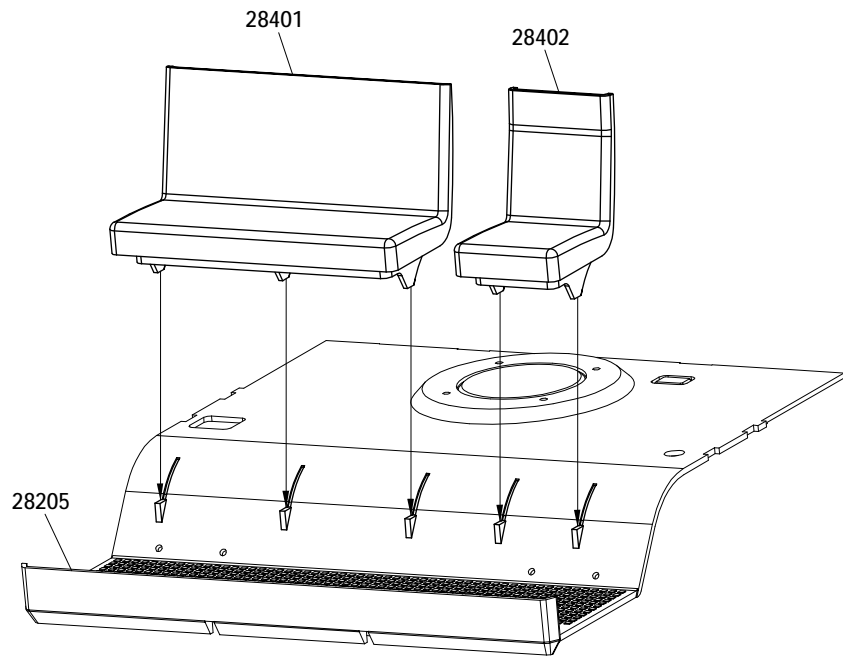

54

12002  M2x10 X4

12102   M2 X4

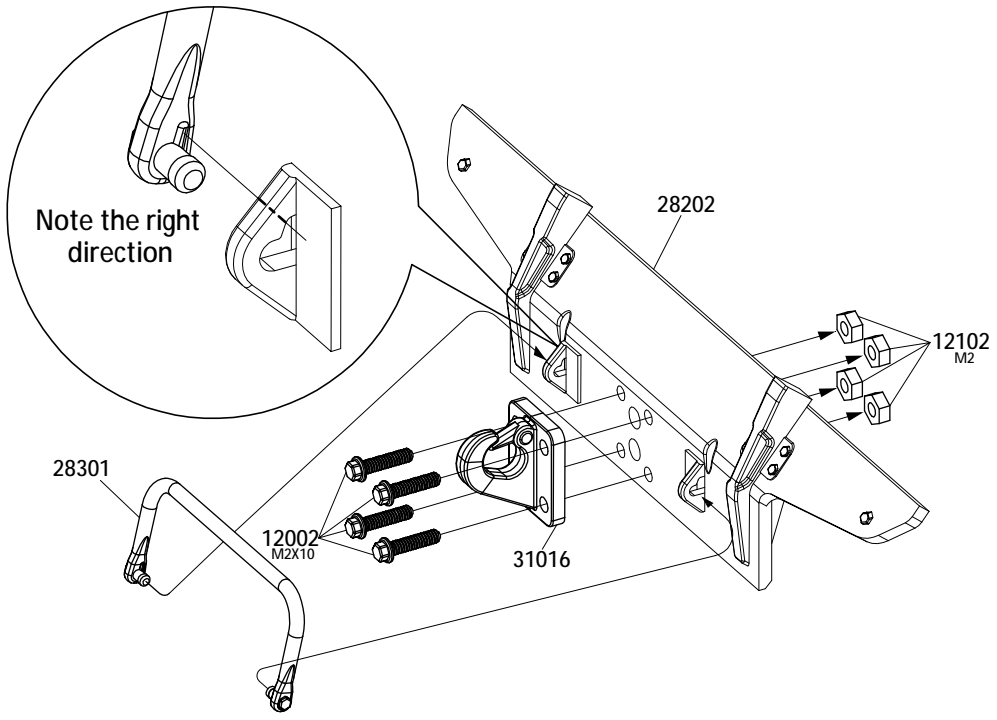

55

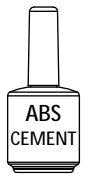



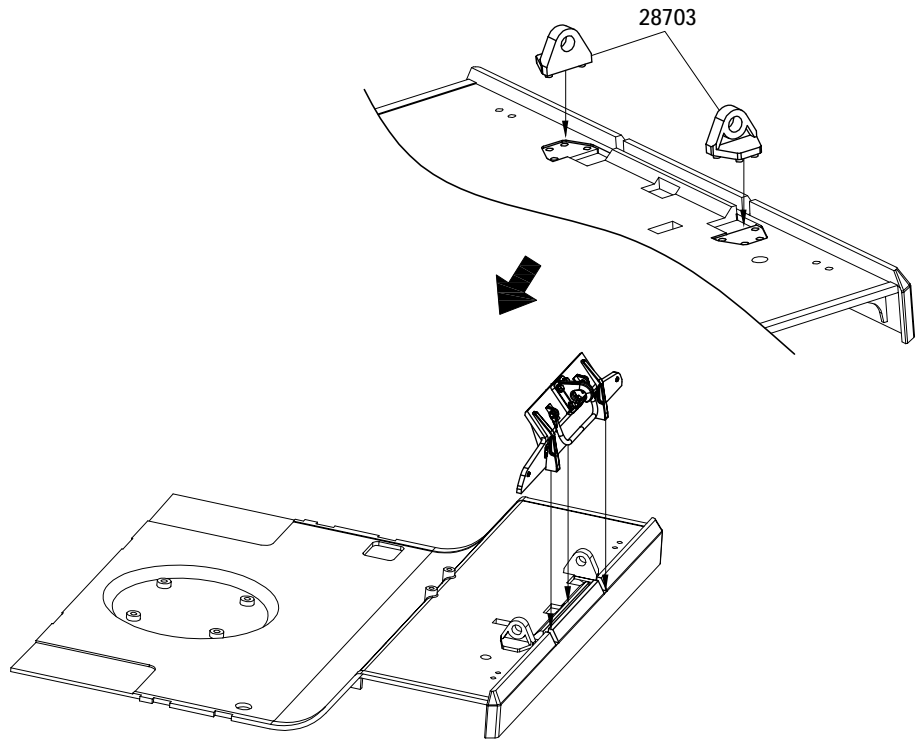

ABS
CEMENT



56

MC6B/C

- 11102  M2x6 X2
- 11205  M3x6 X2
- 11501  ST2.6x6 X4
- 11216  M2.5x6 X4
- 12105  M2.5 X4

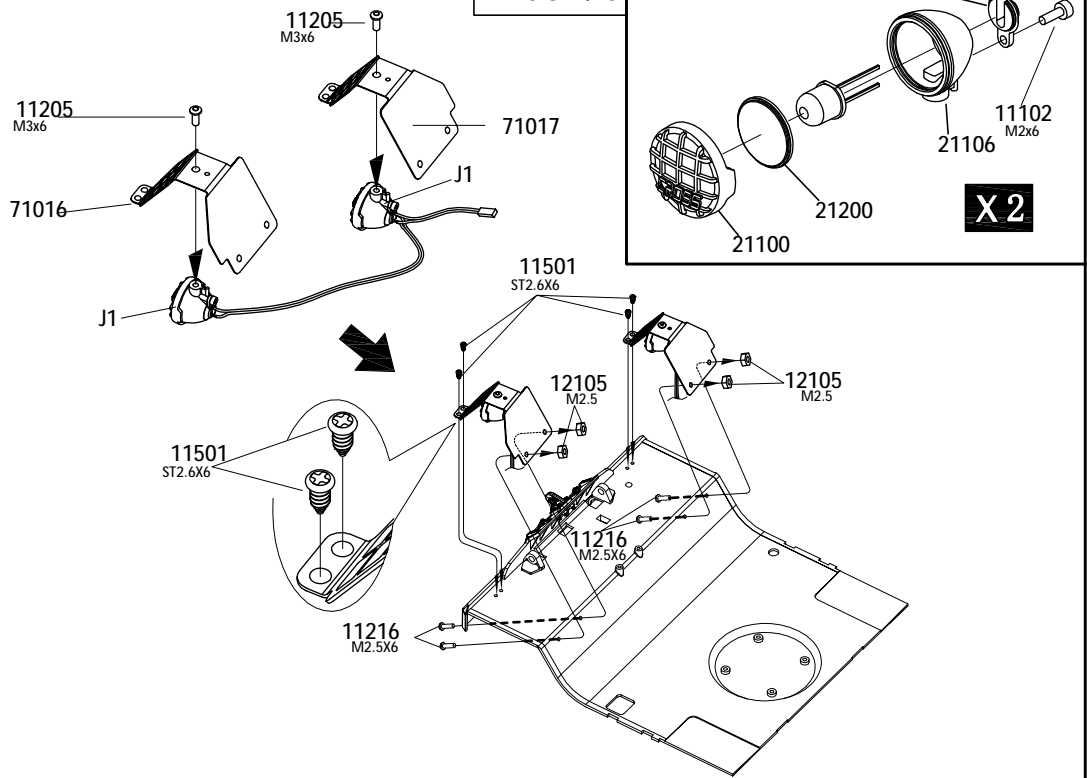

57

MC6B/C

- 11218  M2.5x4 X2

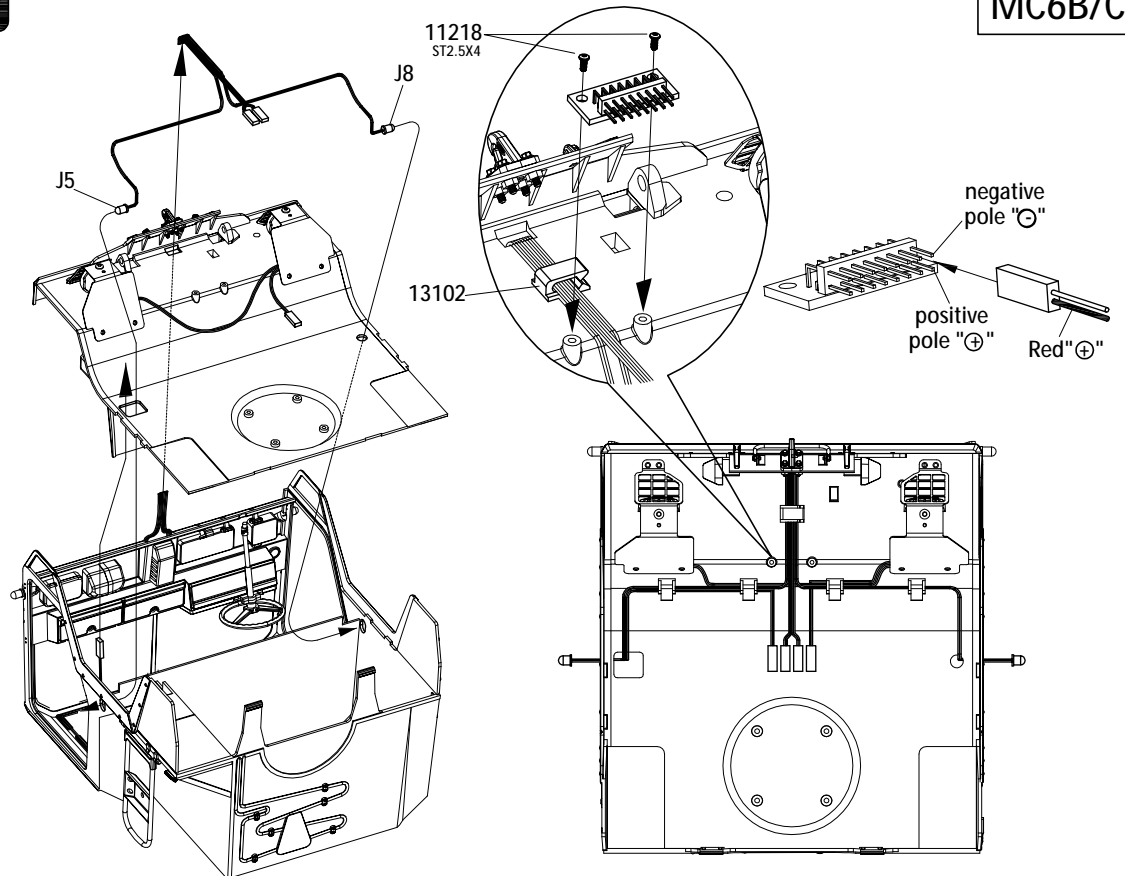

58

MC6B/C

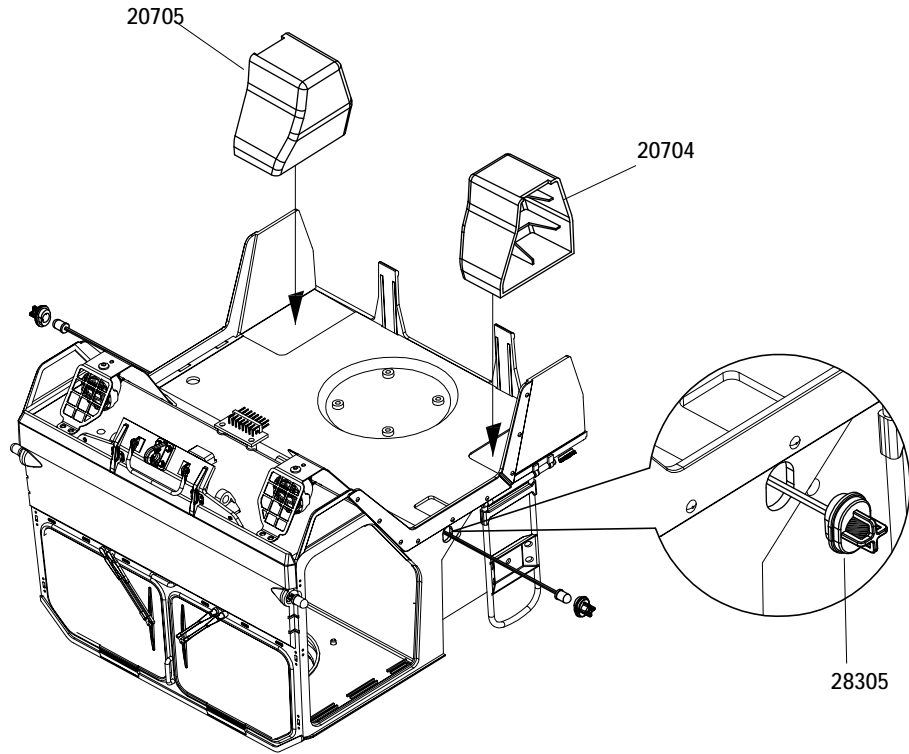

59

MC6B/C

11802  ST1.4x4 X6

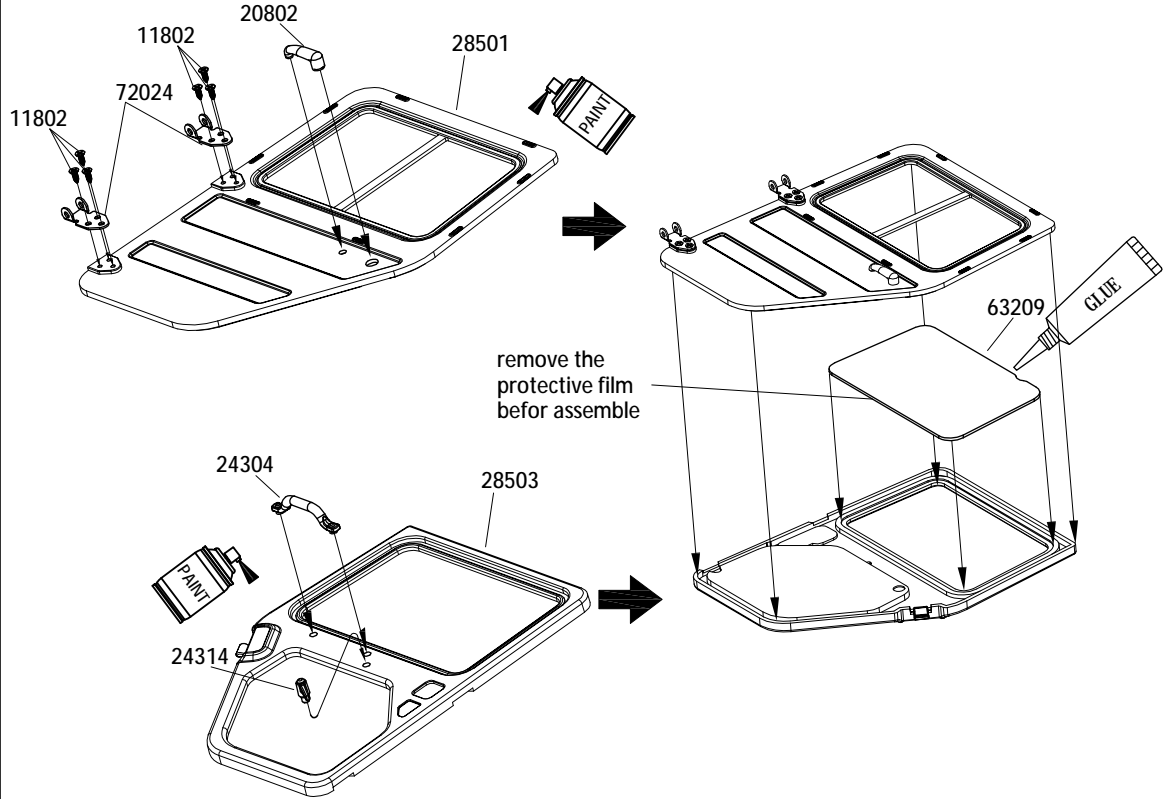

11802  ST1.4x4 X6

60

MC6B/C

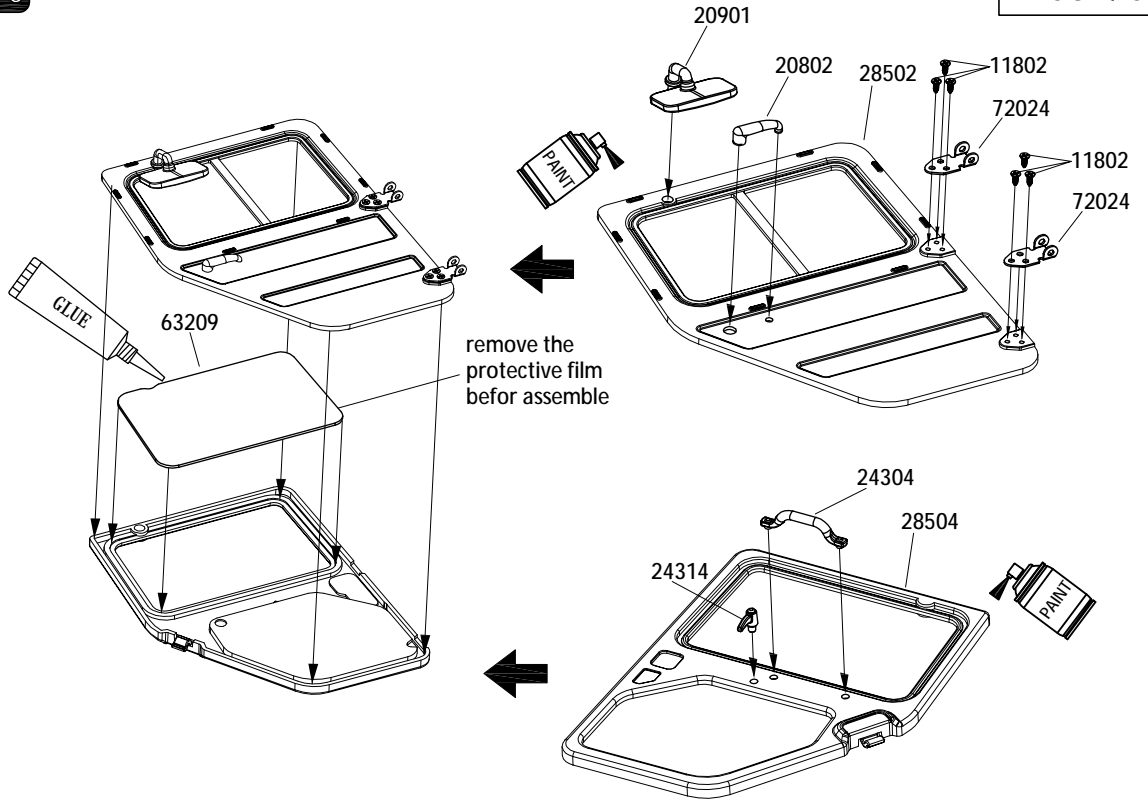
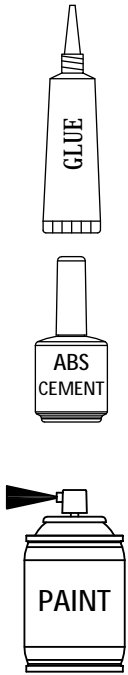

11802  ST1.4x4 X8

61

MC6B/C

11707  M1.6X10X4

12106  M1.6 X4

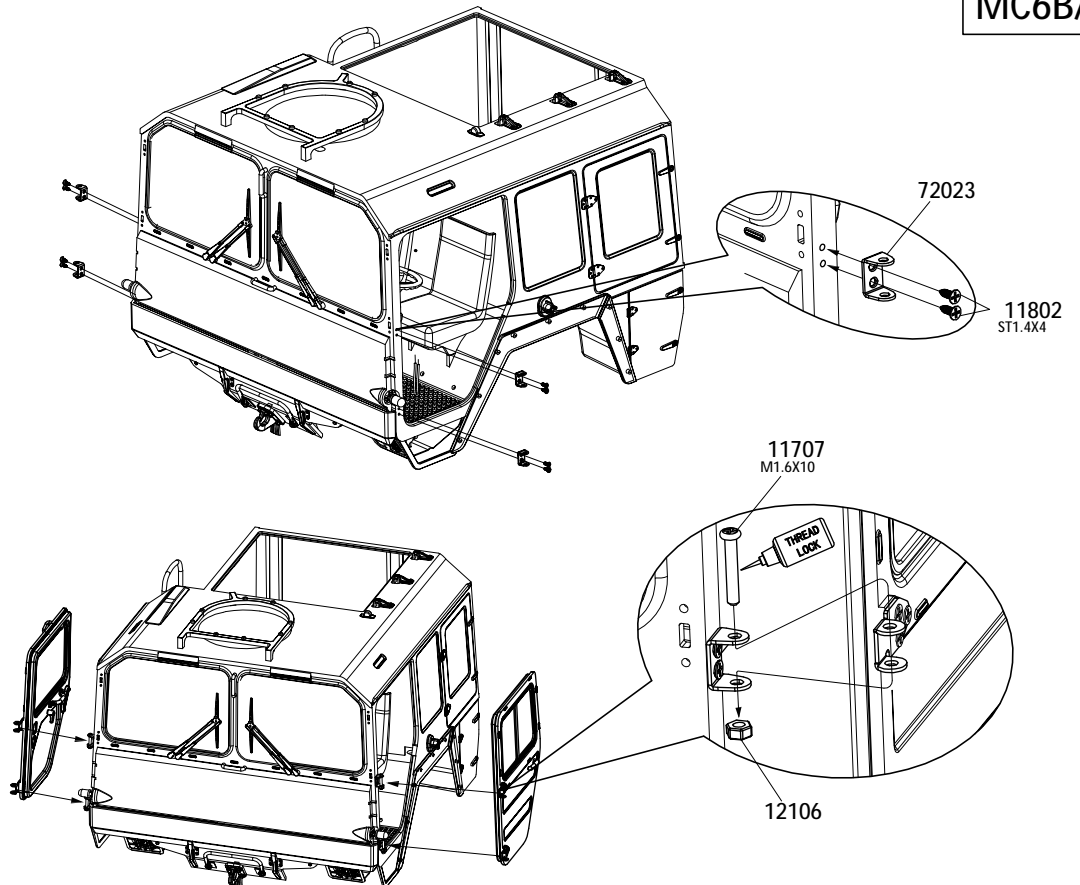

11801  ST1.4x6 X8

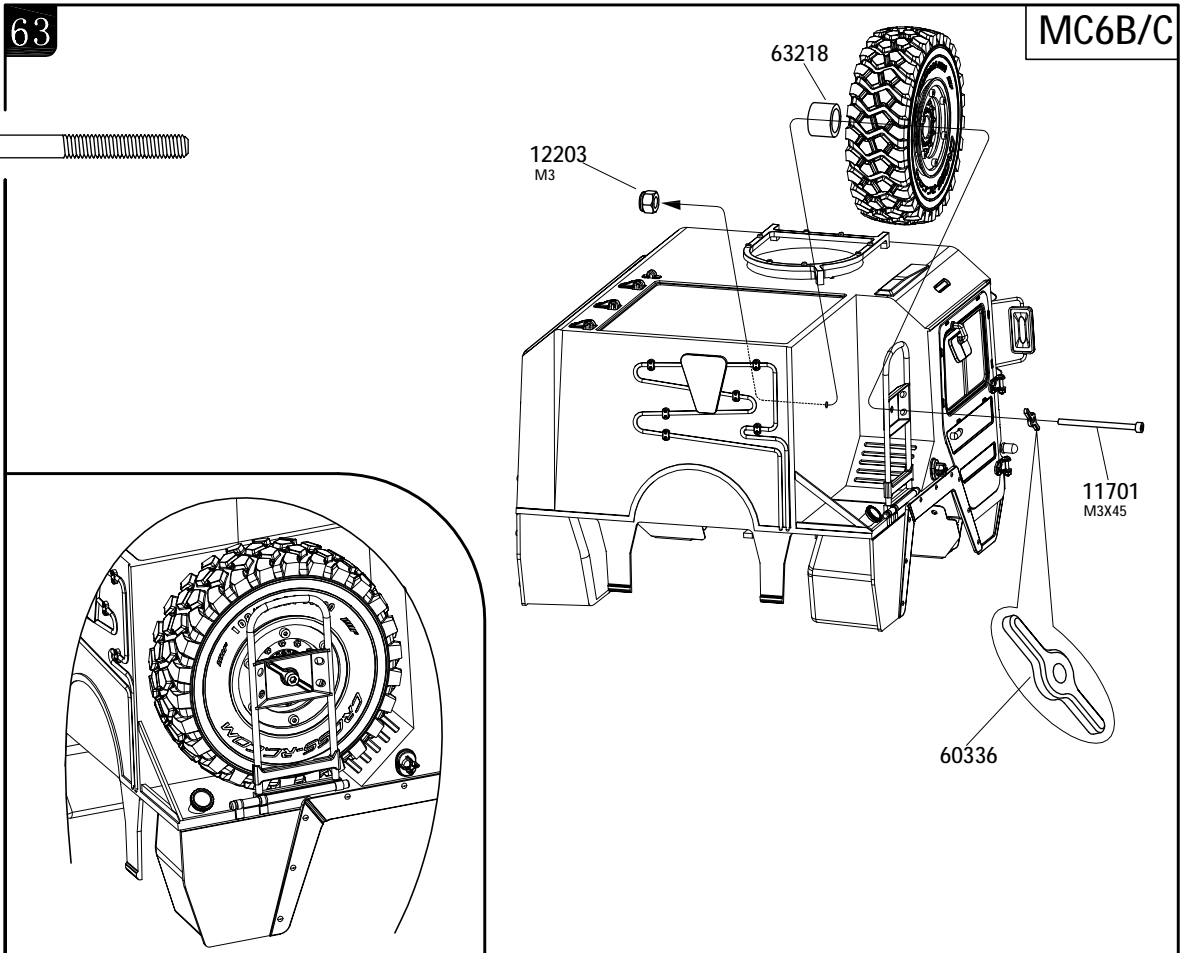
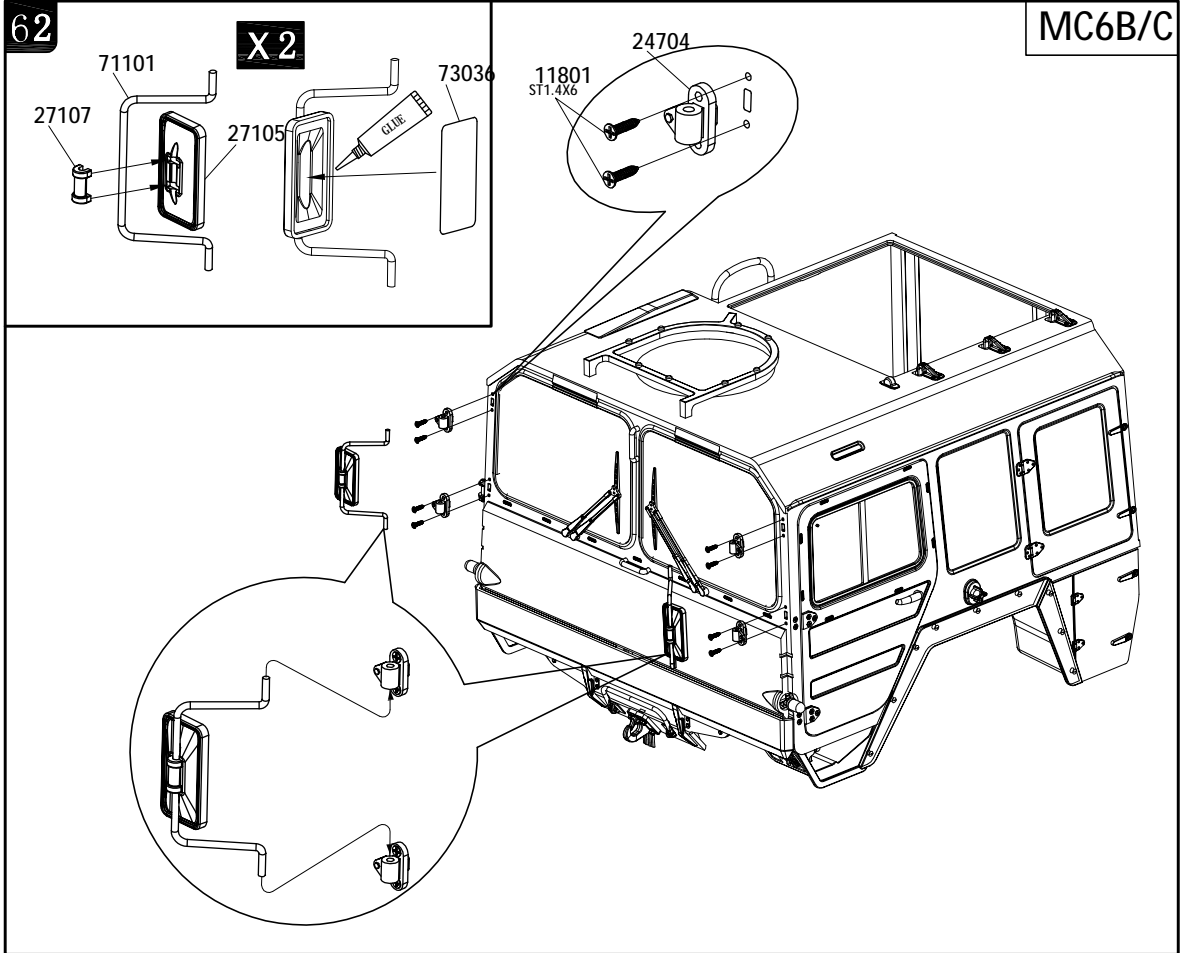
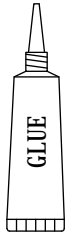

11801  ST1.4x6 X1

64

MC6B/C

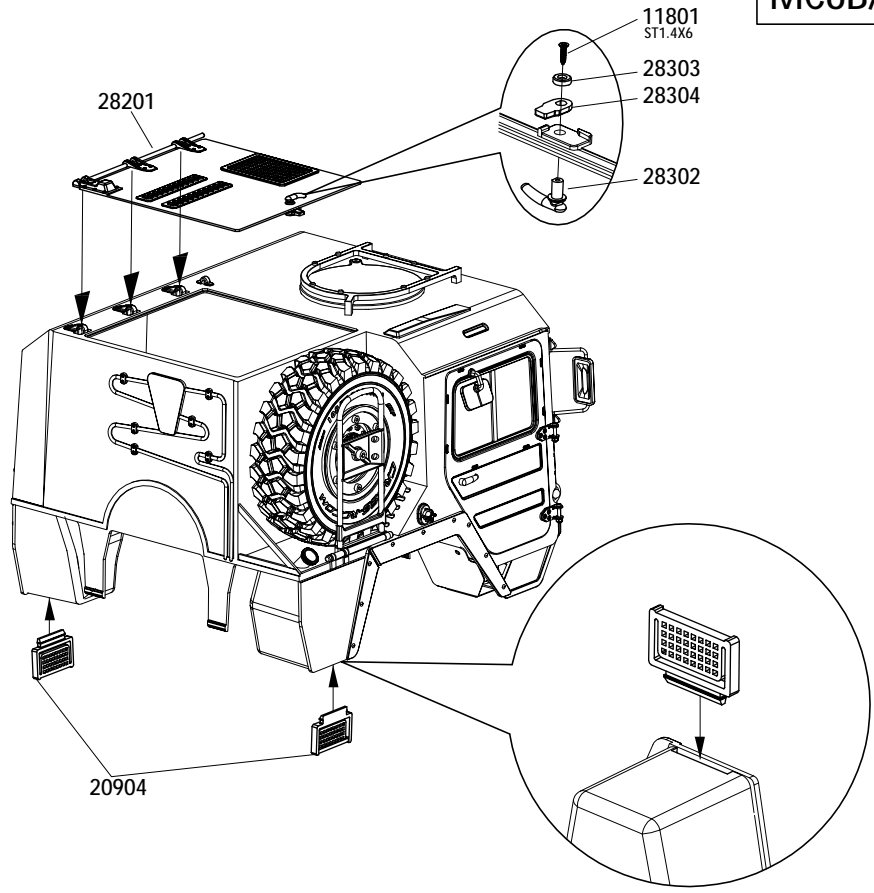

65

MC6B/C

-  ABS CEMENT
-  28307
-  28308

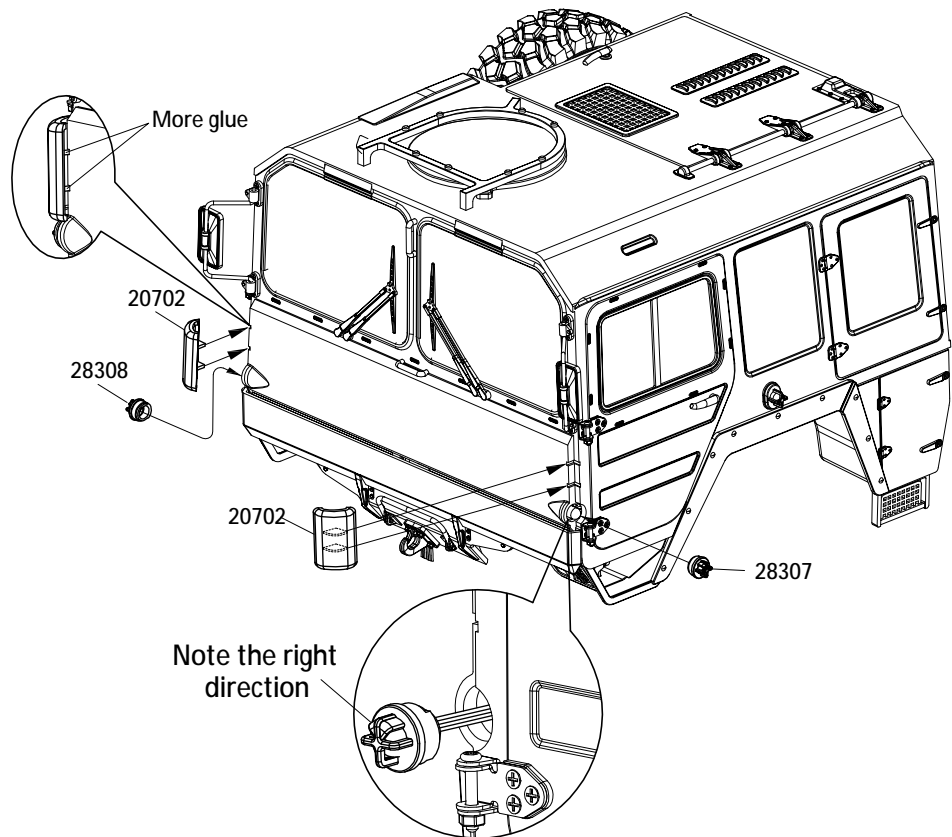

66

MC6B/C

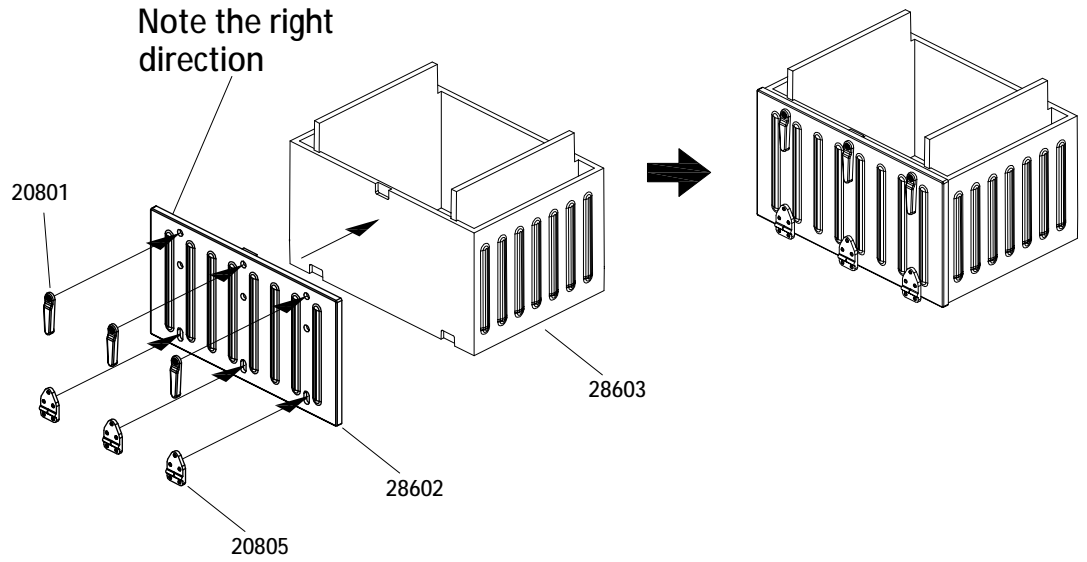

x2

67

MC6B/C

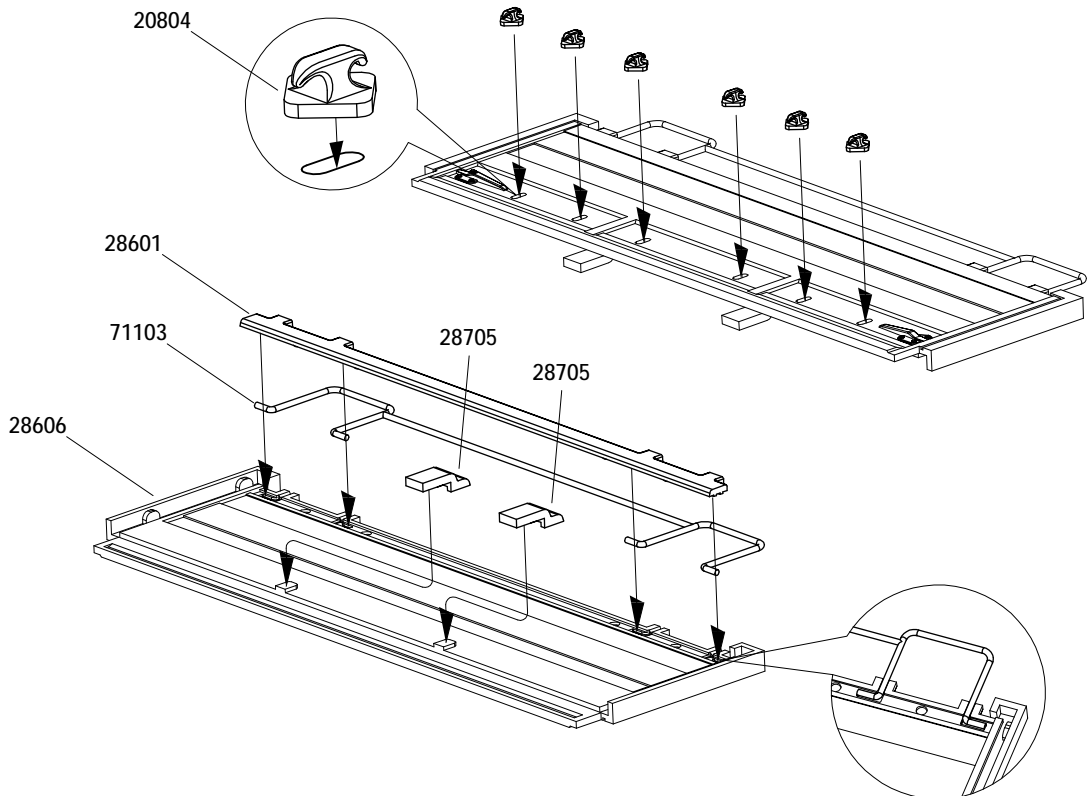

68

MC6B/C

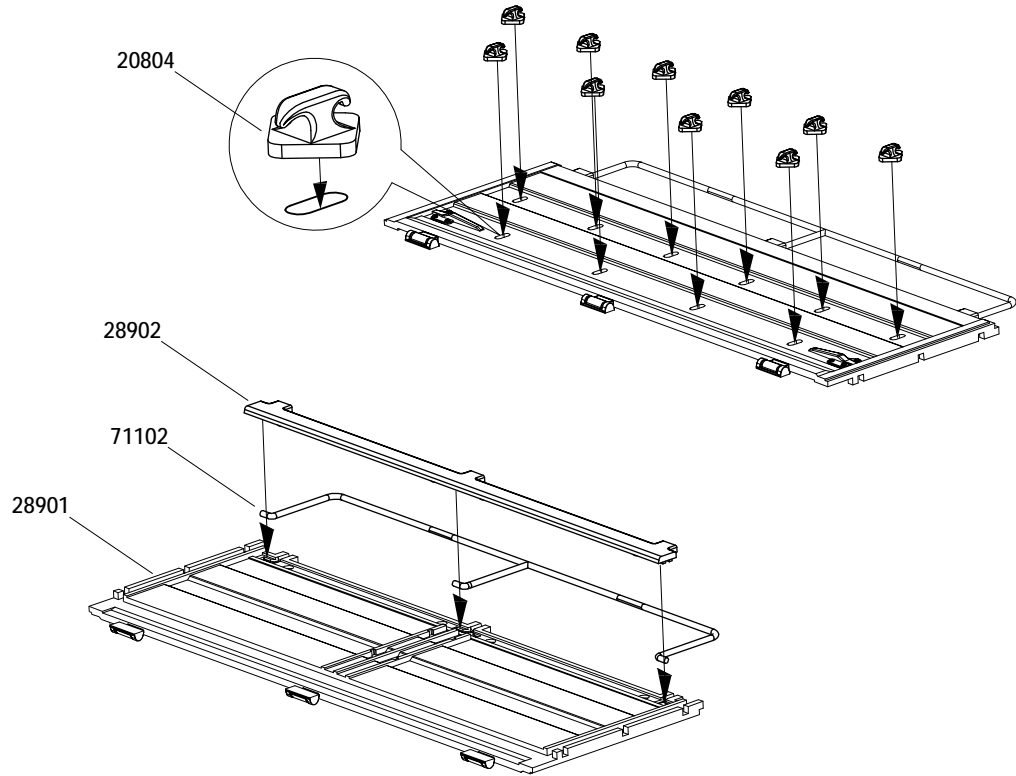

X4

69

MC6B/C

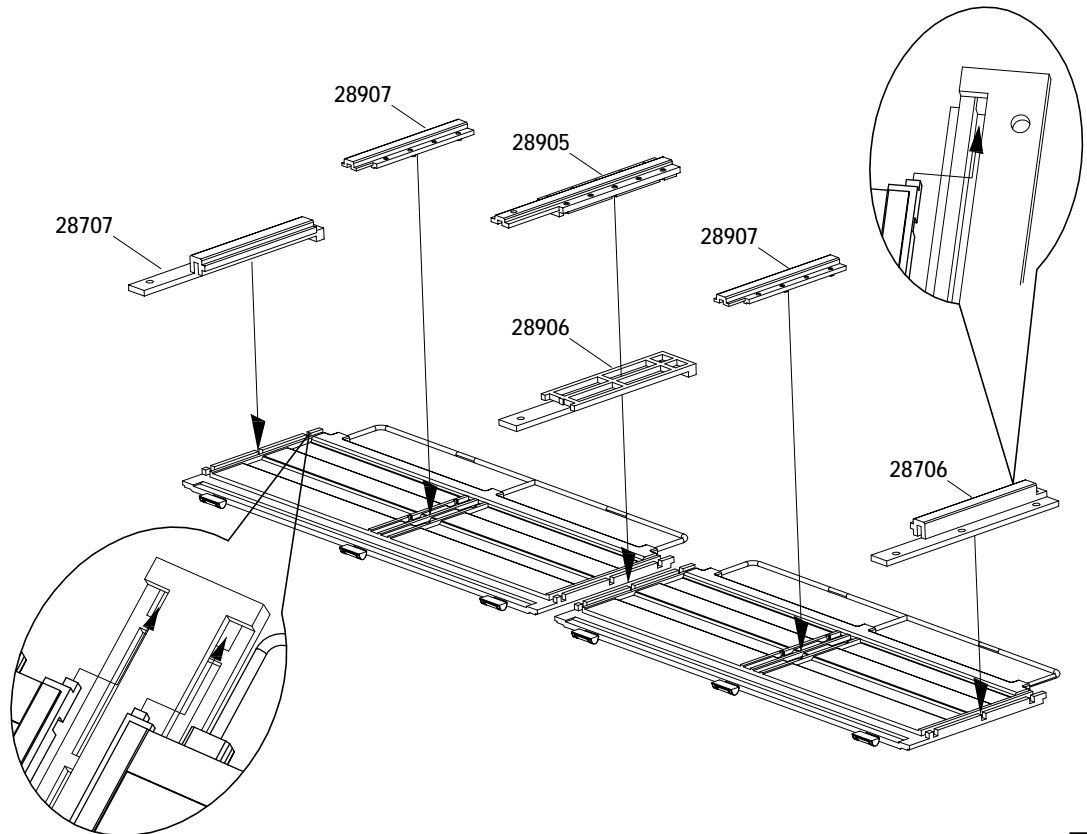
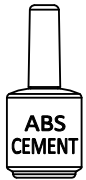

X2

70

MC6B/C

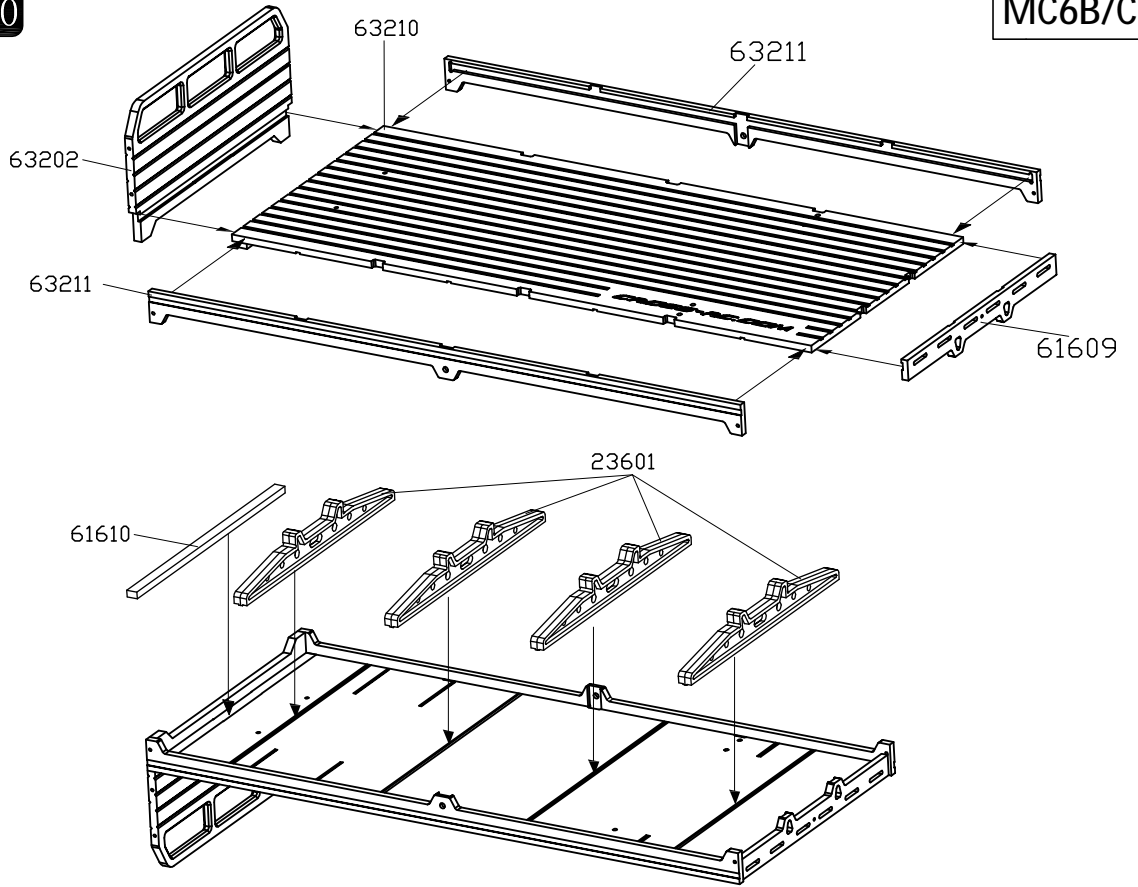

71

MC6B/C

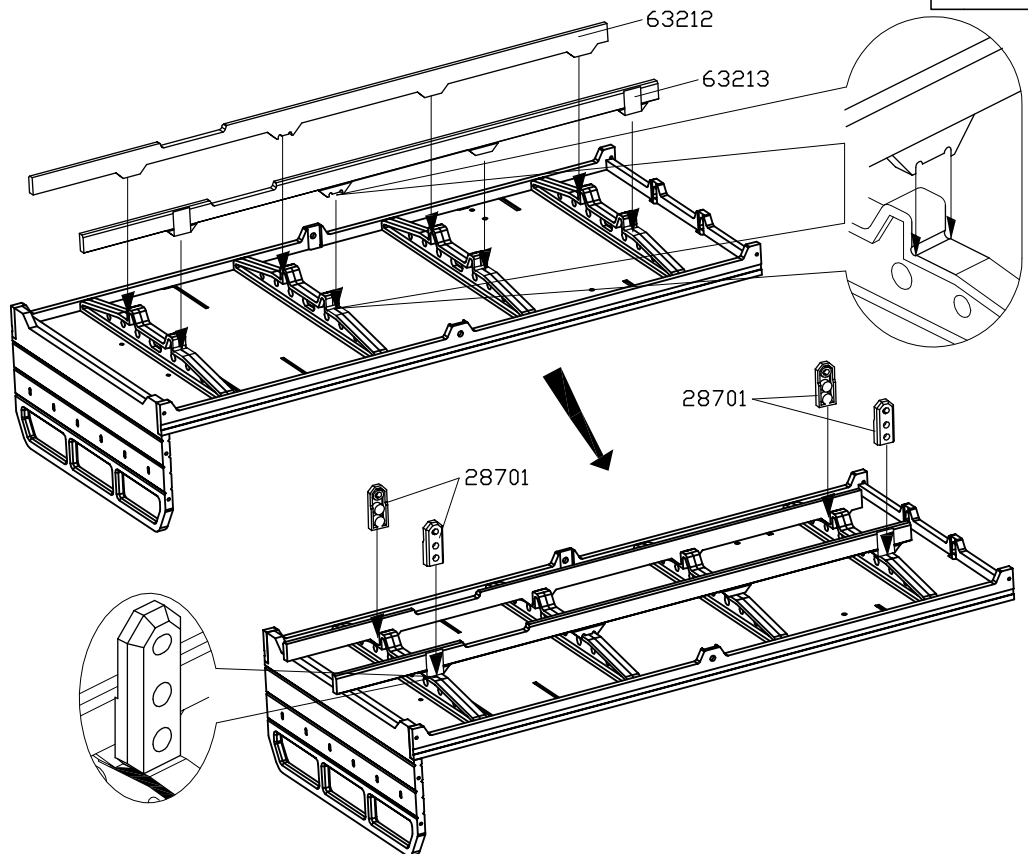
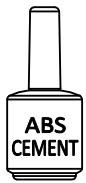



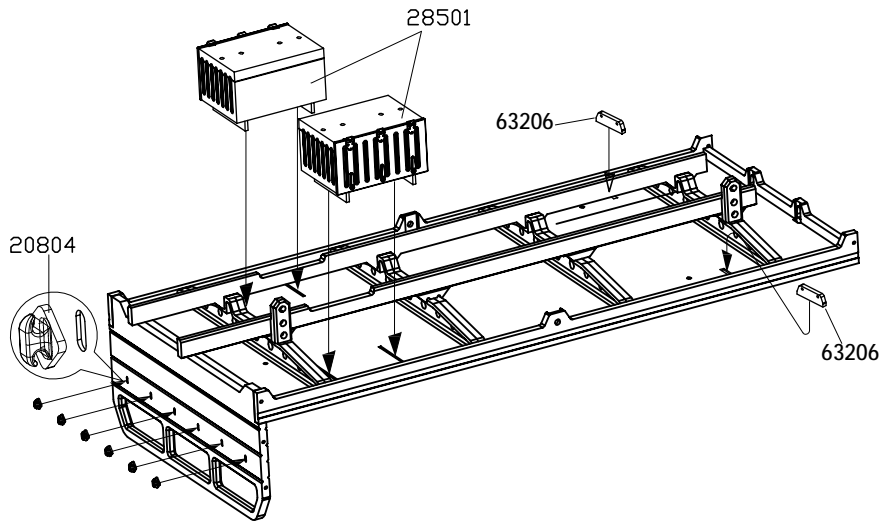

72

MC6B/C



73

MC6B/C

- 11102  M2x6 X4
- 12001  M2x6 X6
- 11207  M3x10 X4
- 12203  M3 X4
- 12102  M2 X6

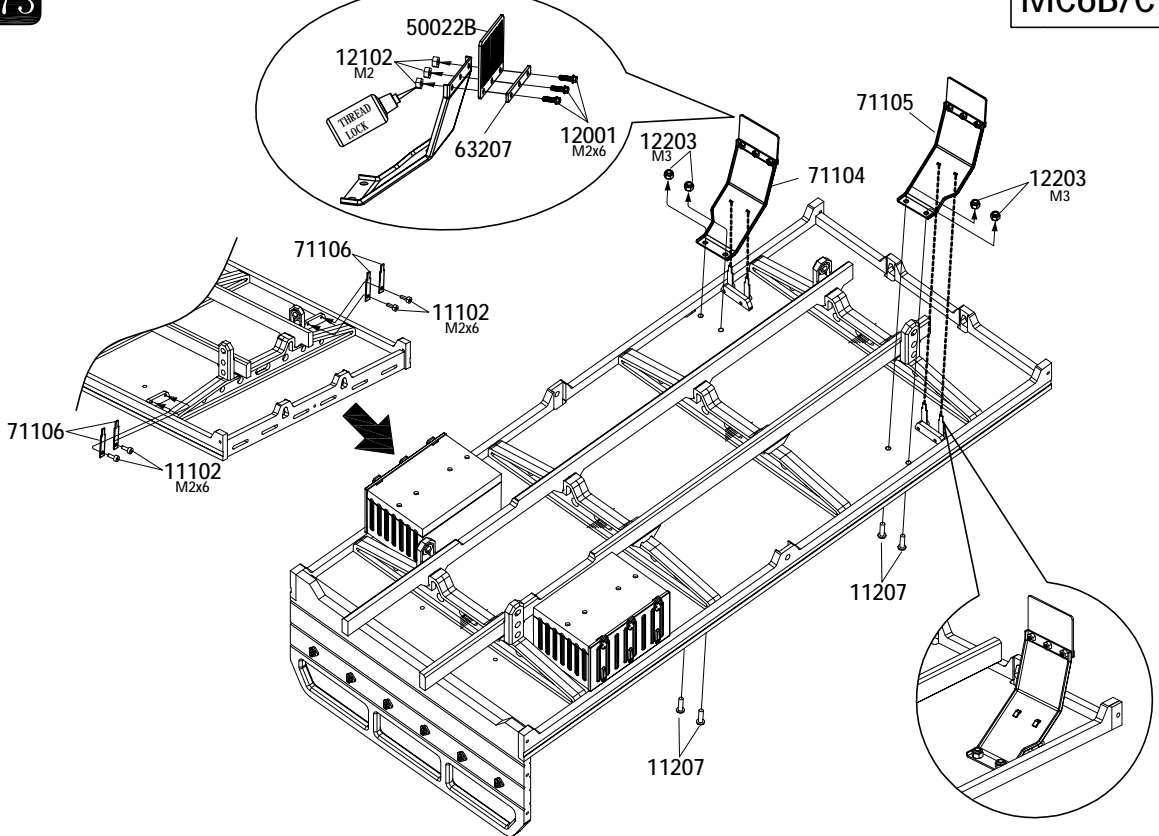

74

MC6B/C

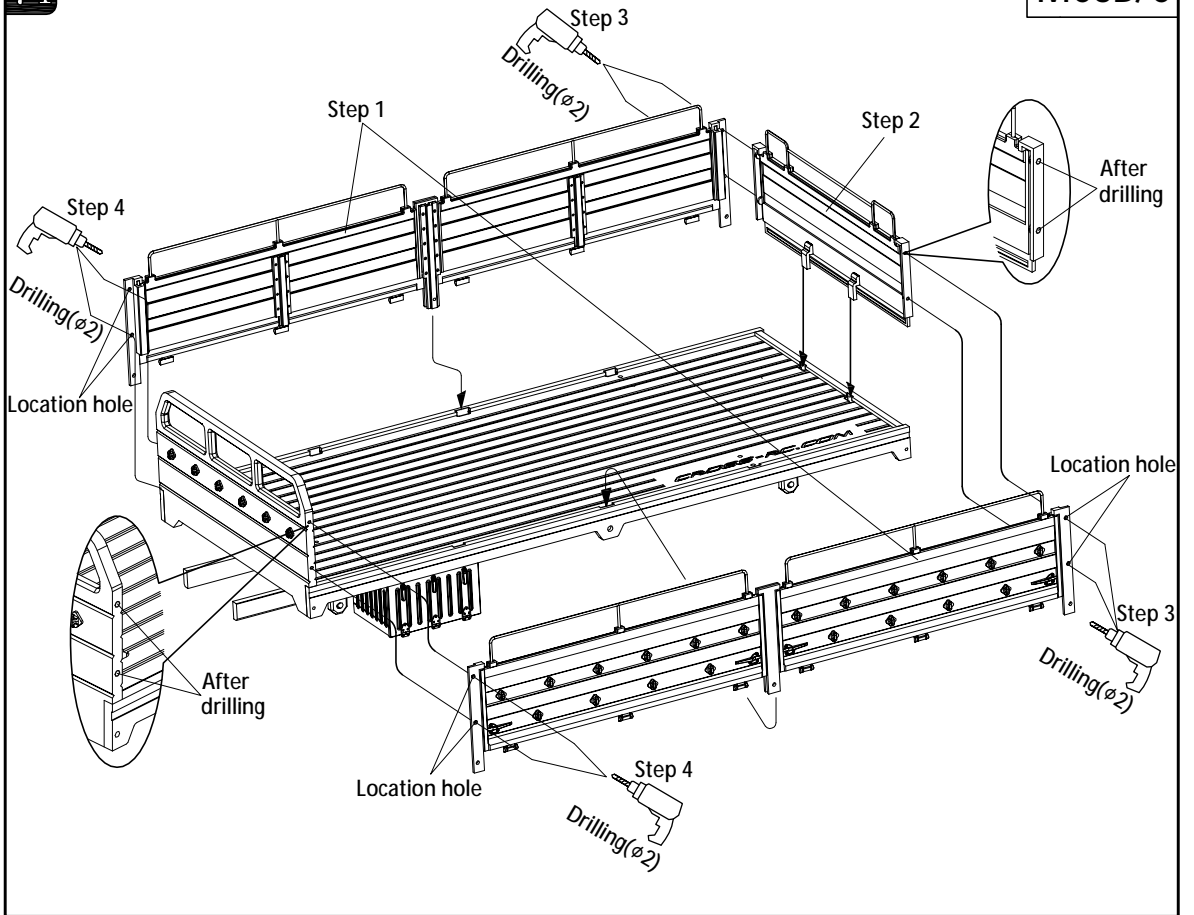
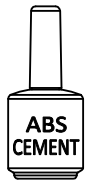

75

MC6B/C

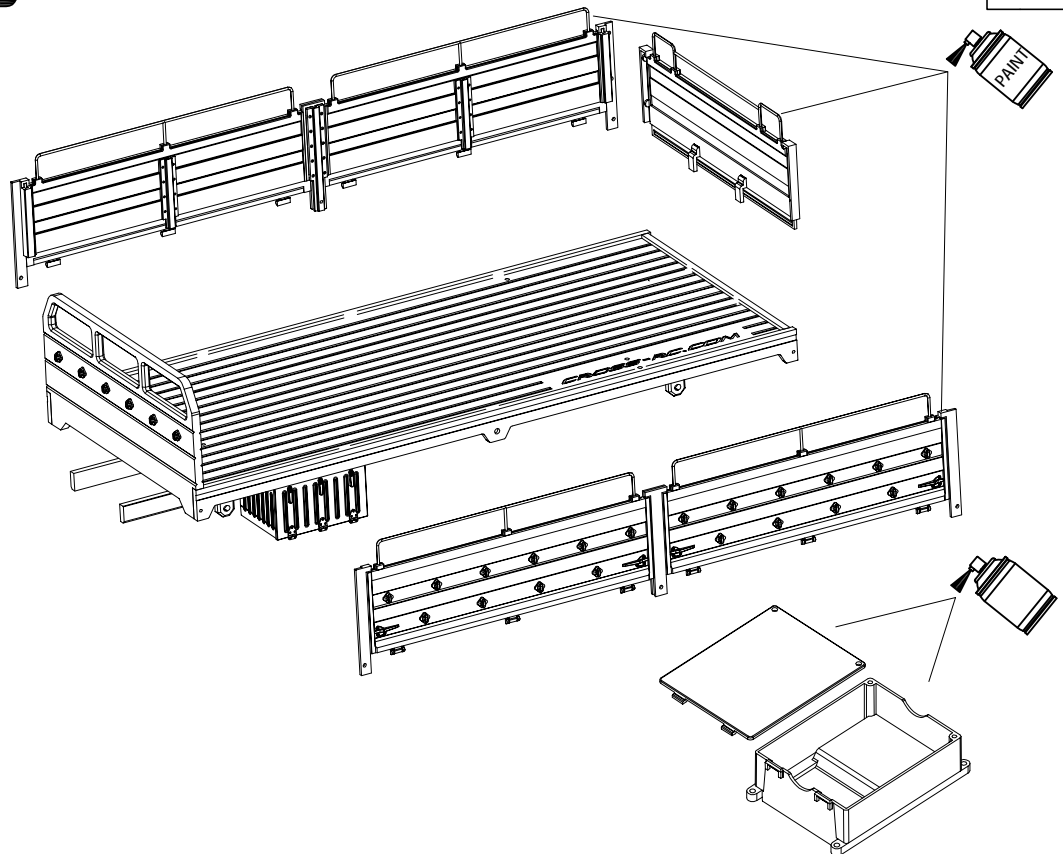

76

MC6B/C

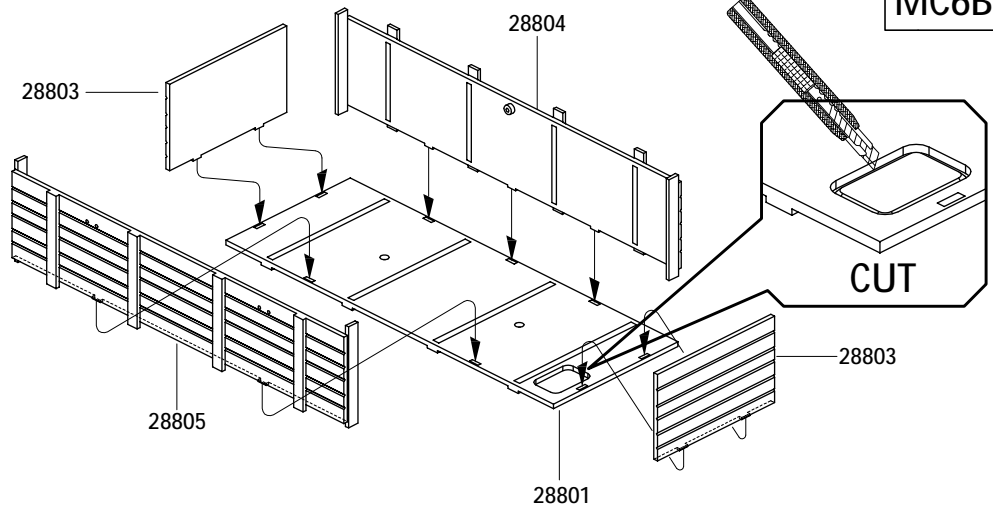

77

MC6B/C

11802 ST1.4x4 X8

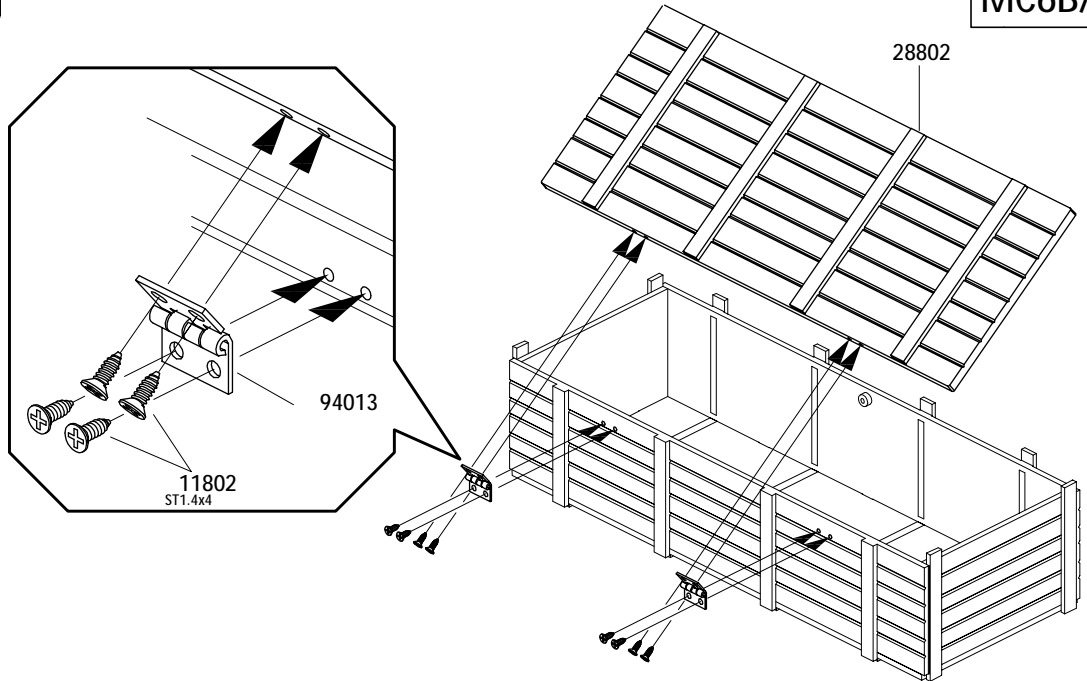

78

MC6B/C

11704 M1.6x6 X2

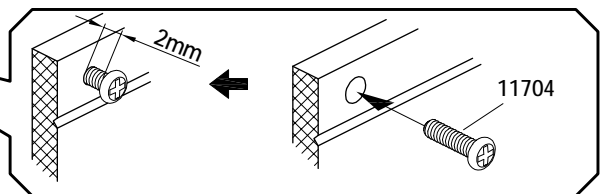
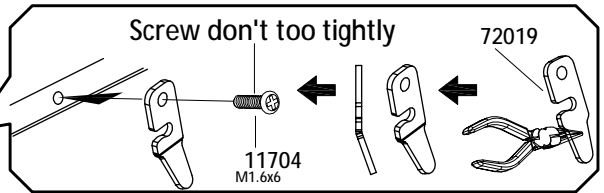
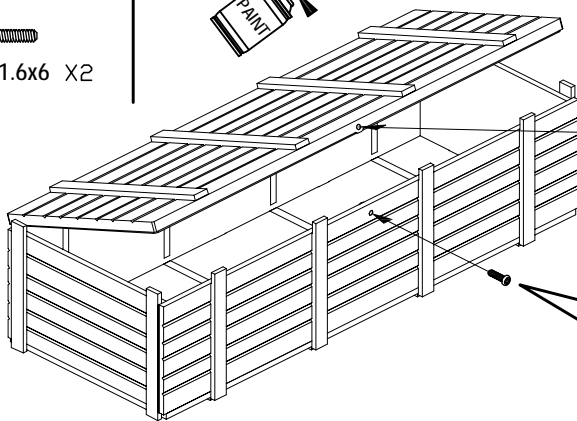

79

MC6B/C

11207 
M3x10 X2

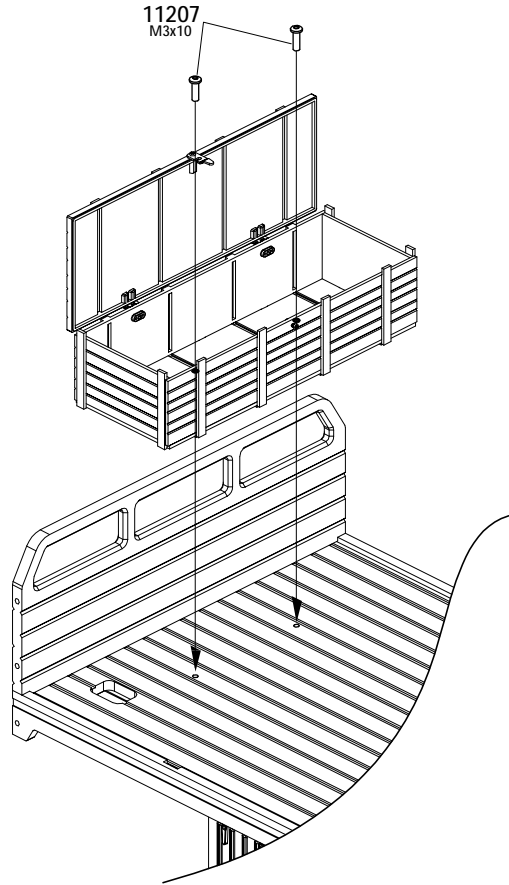

80

MC6B/C

11106 
M3x8 X4

11107 
M3x10 X4

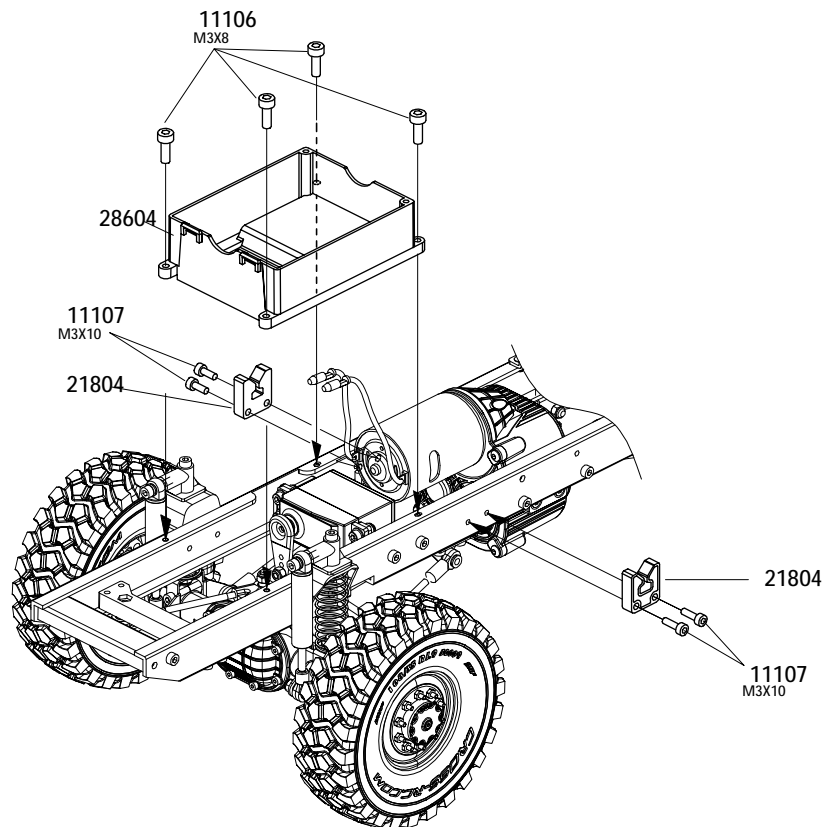

81

MC6B/C

11102 
M2x6 X4

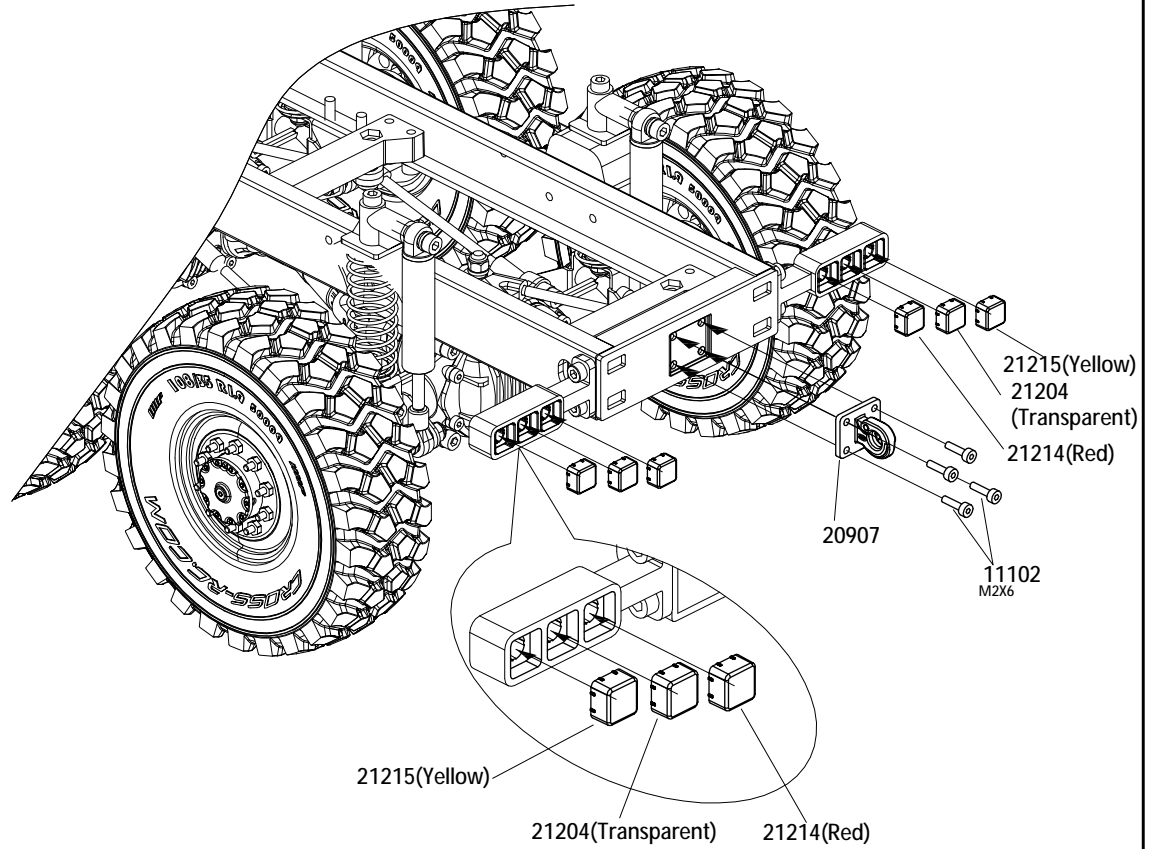

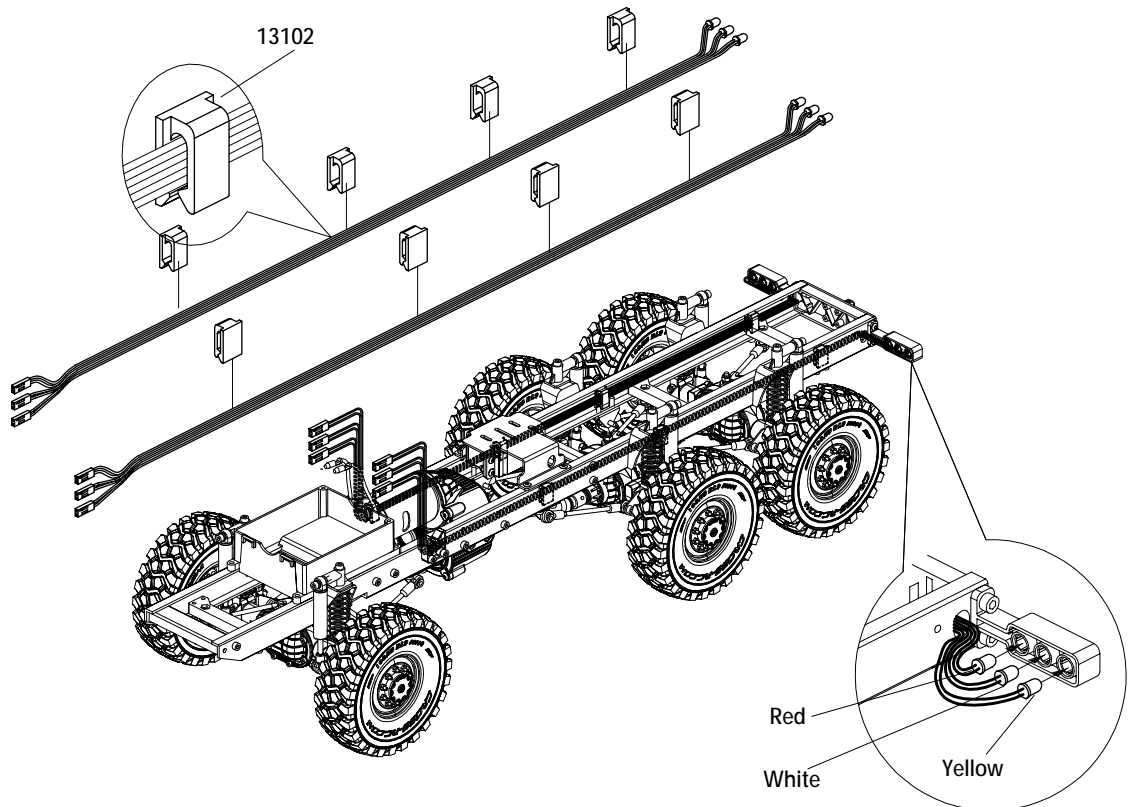

82

MC6B/C



83

MC6B/C

- 11108  M3x12 X4
- 14103  $\phi 3.2 \times \phi 9 \times 1$ X4

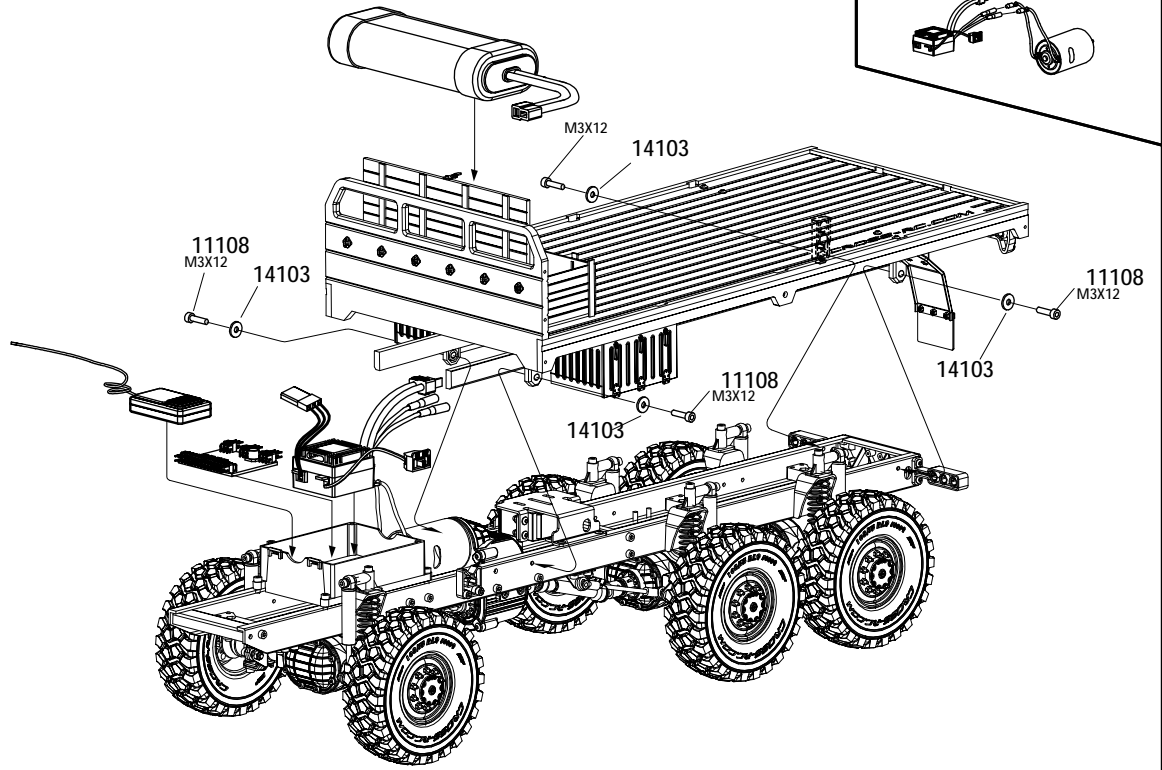
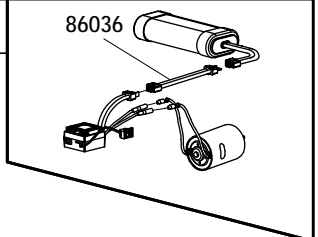

84

MC6B/C

- 11205  M3x6 X2

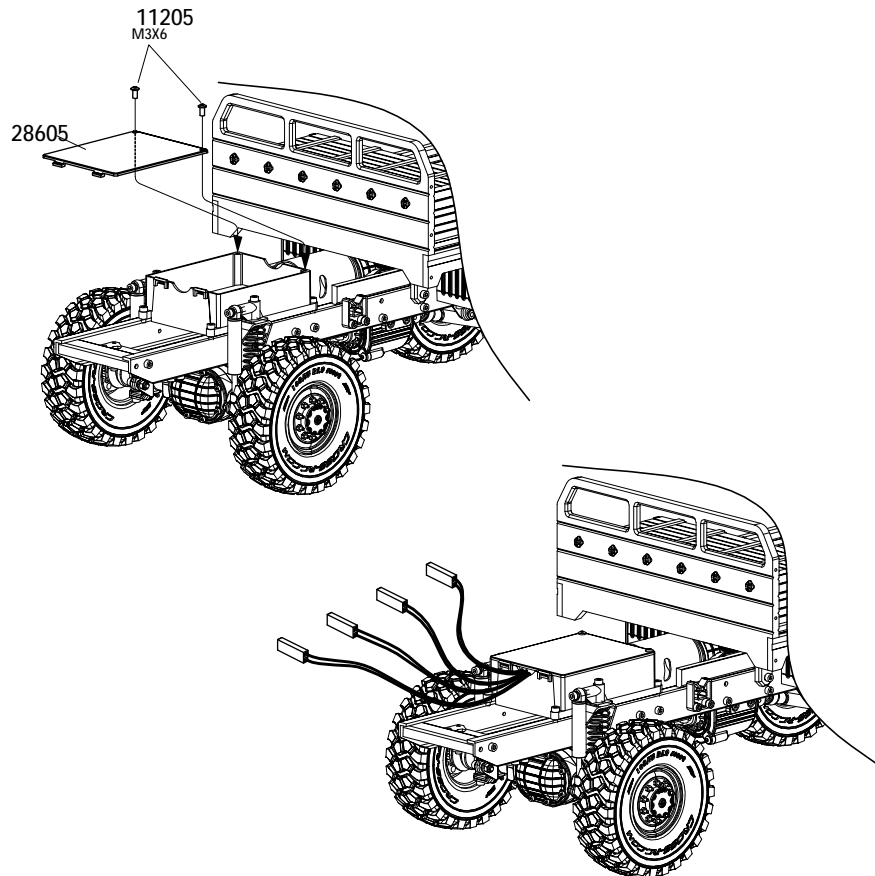

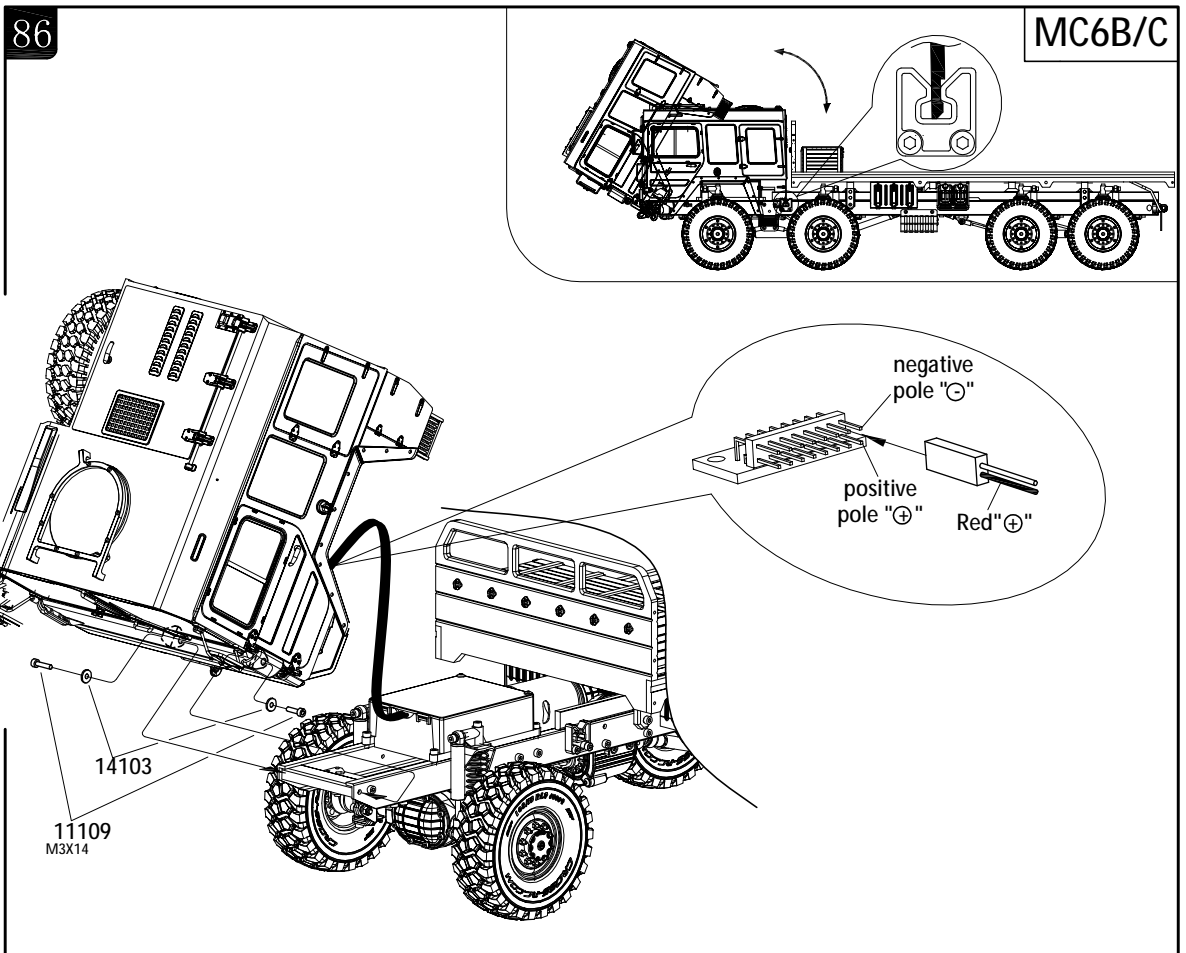
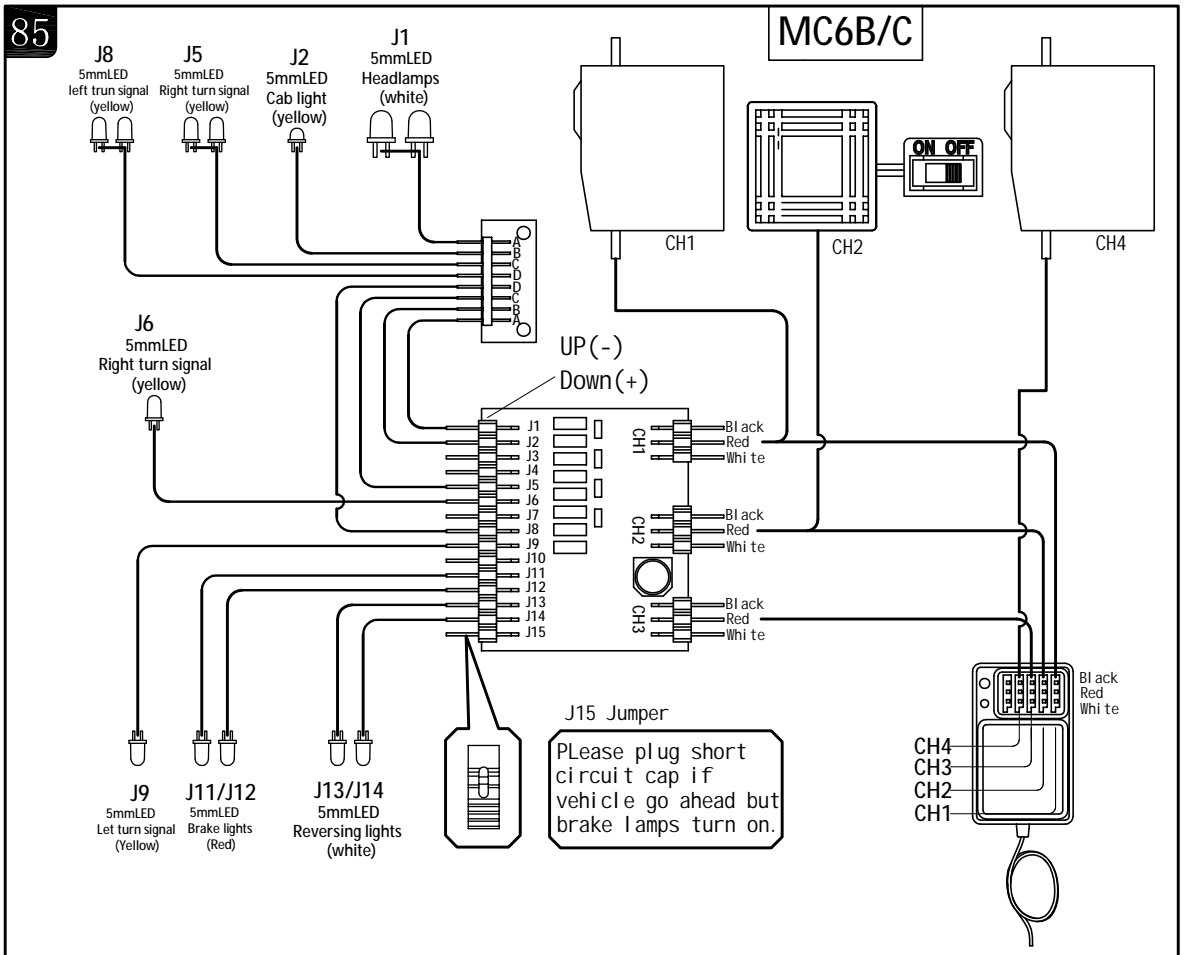



87

Flat bed

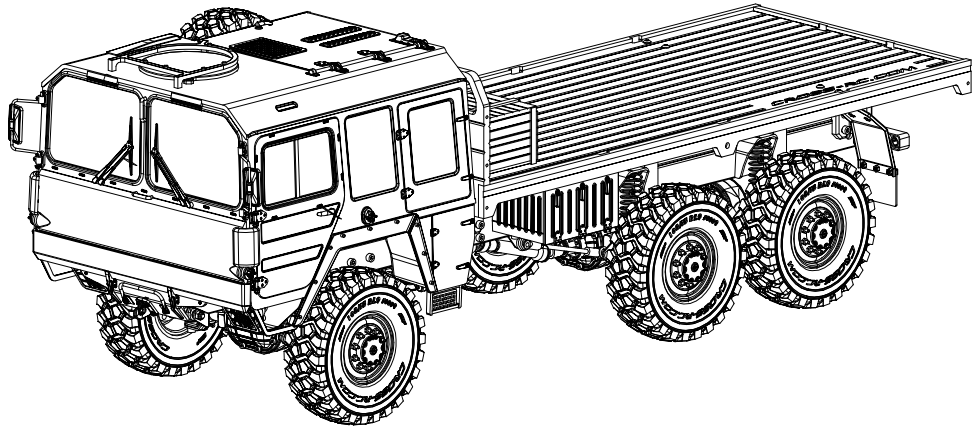
MC6B/C



11216 
M2.5x6 X14

88

MC6B/C

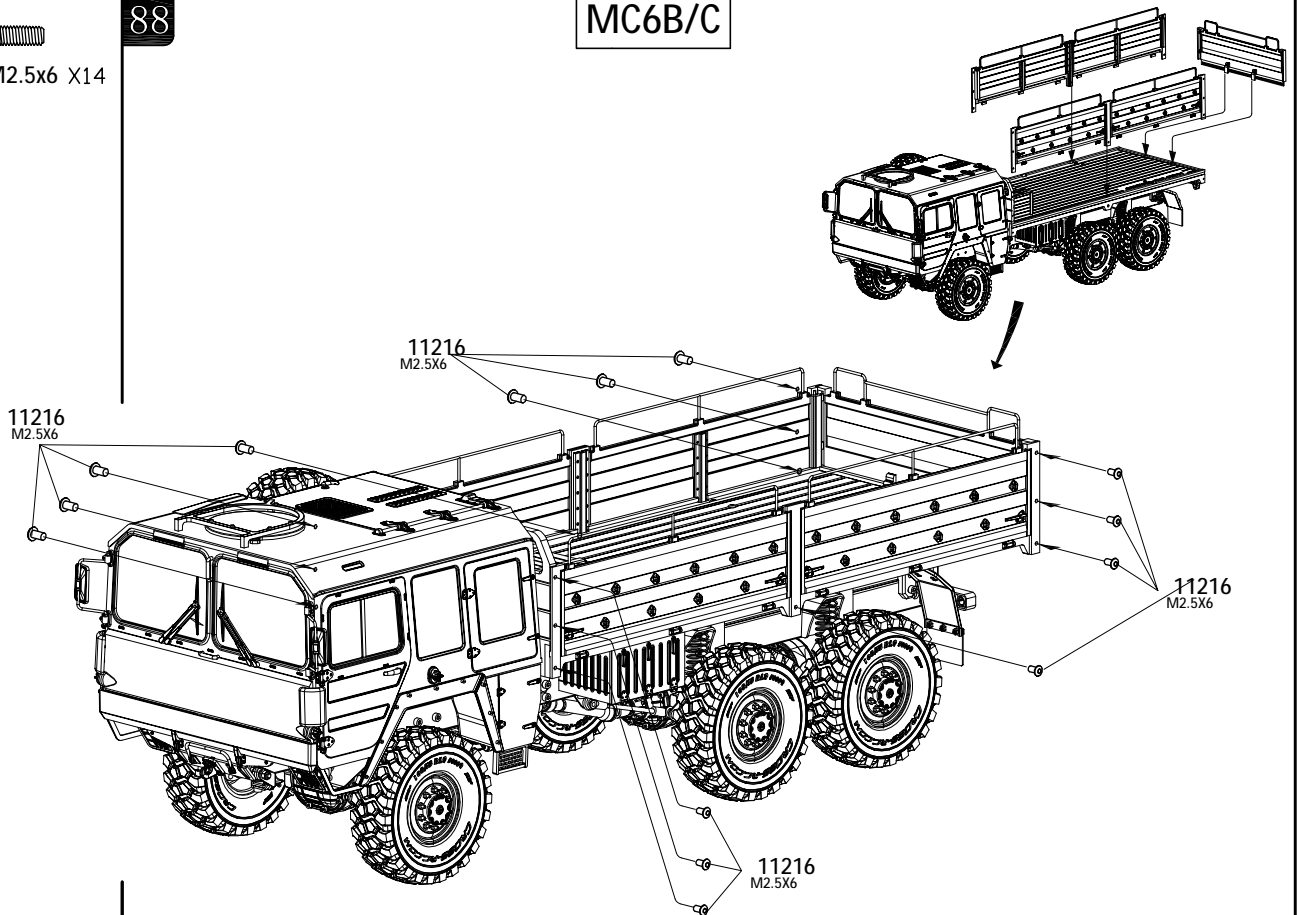

Cargo bed

